

Halton Windis DWE – Air curtain

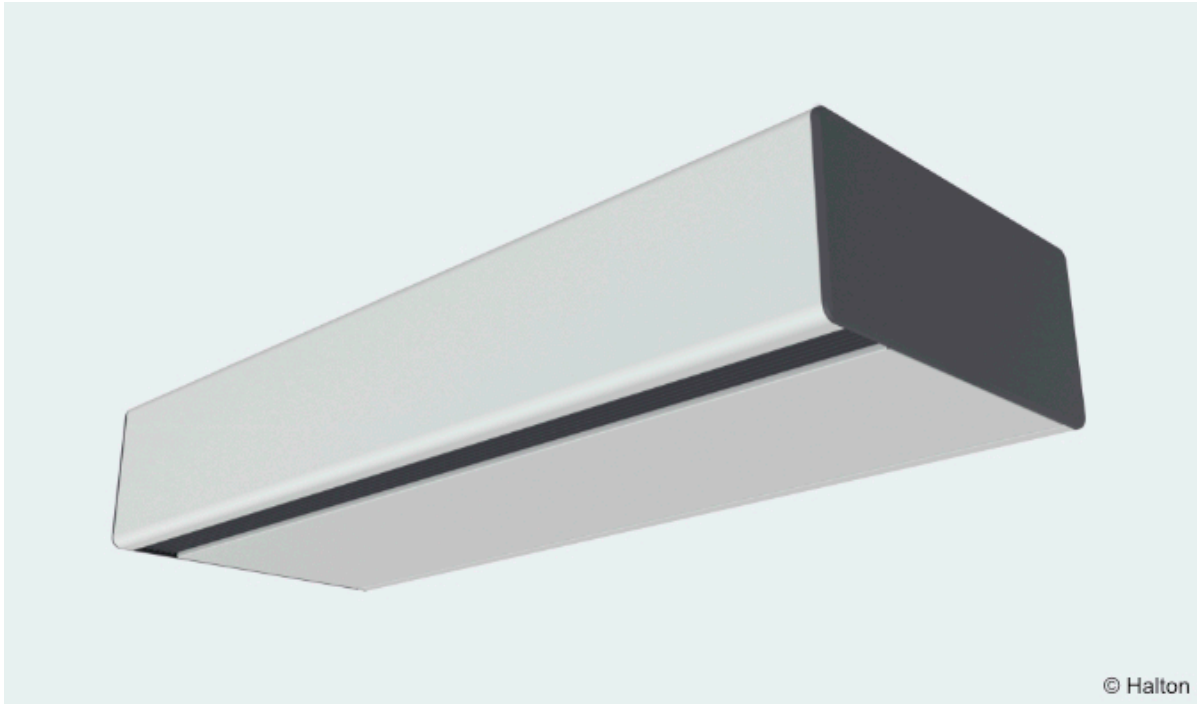

Overview

Halton Windis DWE is an air curtain that generates an invisible and uniformly controlled air stream directed downwards in an open doorway. It is a water-heated air curtain designed for exposed installation. It is compact and compatible with various entrance types, and installation is up to a maximum height of 3.5 m. With its integrated energy measurement, energy consumption remains under control. The unit employs EC motors and features with adjustable impulse force for an efficient air barrier function.

Application area

- Excellent for retail spaces, shops, offices, schools, and daycares.
- Interior or exterior doorways.
- Designed for horizontal installation directly above door openings with a maximum height of 3,5 m.

Key features

- Fast and easy to install, requires no opening of the product for connection.
- Exposed or suspended mounting and water heated.
- Connectivity to automation is simple and via a QR code.
- Built-in thermal energy measurement.
- Intelligent Controller - with web server and ready-to-use Modbus and BACnet interfaces.
- Adjustable

- Integrated water valves.

Operating principle

Fig. 1. Operating principle of Halton Windis DWE air curtain

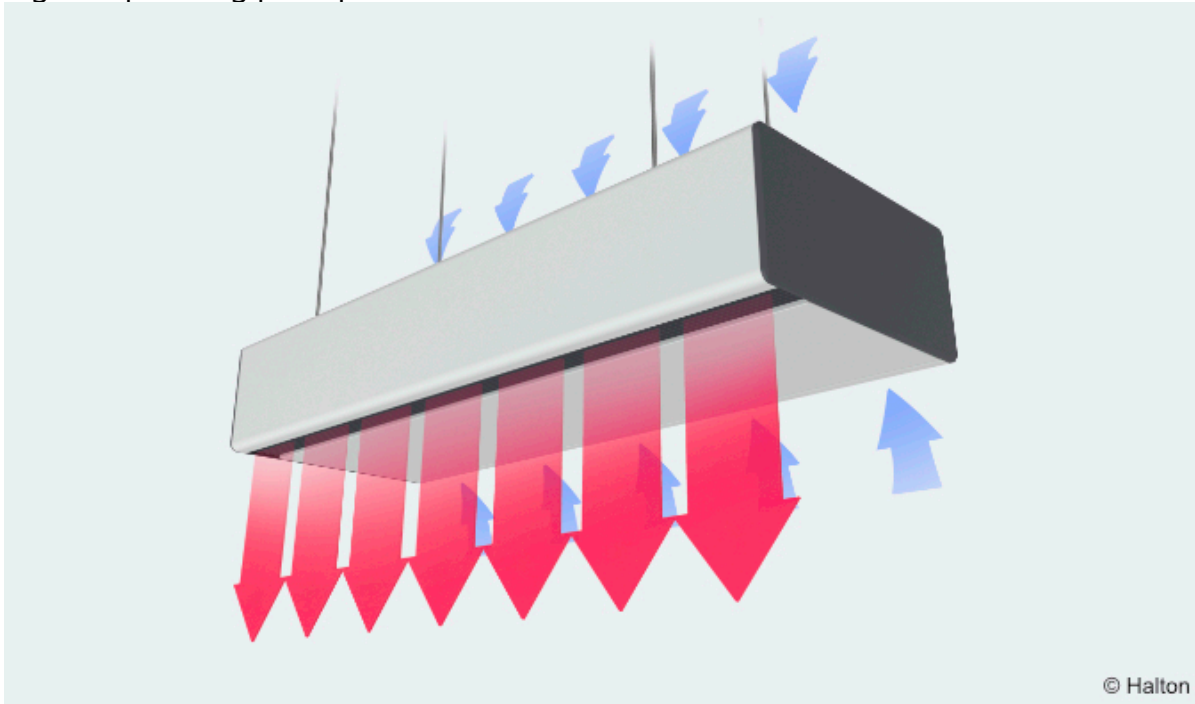

Air curtains, distinguished by their unique aerodynamic design, offer a highly efficient solution for separating two temperature zones or two environments. This unique design not only provides effective separation but also contributes significantly to energy conservation, making it a cost-effective choice.

When faced with challenges of natural heat exchange through open doors, air curtains step in as a practical solution. These curtains effectively separate two areas or environments, halting the natural heat transport and thereby playing a crucial role in energy conservation.

In principle, an air curtain is a device equipped with a fan and a heat exchanger (water or electrical). It operates by pushing air to the floor in a smooth, laminar flow, creating a 90% air seal. This seal, akin to an invisible waterfall, effectively stops heat transfer, dust, and flying insects, thereby maintaining a controlled indoor environment.

Key technical data

Feature	Description
Airflow rate	73-1404 l/s or 1750-3900 m ³ /h
Sound pressure level	30-77 dBa
Dimensions	Height [H] = 600 mm
	Width [W] = 1017, 1517, 2017, 2517 mm
Weight	46 - 95 kg
Adjustability / Positions	3
Mounting height	3,5 m (max)

Features and options

Feature	Description
Color	Frame: RAL 7035 Grill: RAL 7024
Casing	Galvanised steel
Fans	EC - motor, Ball bearings
Heat exchanger	Copper (3/8"), aluminium, G1" thread, max 6 bar/100°C
Electrical connections	Power supply 2 m, safety grounded plug
Other connections	M12 connector, Ethernet, USB
Standard delivery	2-way heating valve, Heating energy meter, Filter G4, Room sensor NTC10
Internal temperature sensors	<ul style="list-style-type: none"> • Water in and water out • Air in and air out
Cables	10m cable - BMS - RS-485 connection (M12 connector)
	10m cable - Room sensor (M12 connector)
	10m cable - Door switch (M12 connector)
	10m cable - Slave device (M12 connector)

Product selection

Technical data (Air, volume and sound)

Halton Windis DWE, 1000

Regulation	Air volume		HVC	Sound pressure level	Power consumption
[V]	[l/s]	[m ³ /h]	Position	[dB(A)] 10 m ² sab	[W]
10	929	3345	1	77	666
8	797	2869	1	73	384
6	535	1926	1	64	149
4	307	1107	1	51	44
2	130	469	1	34	17
10	929	3345	2	77	667
8	797	2869	2	73	383
6	517	1861	2	64	149
4	303	1091	2	51	44
2	123	444	2	34	17
10	929	3345	3	78	667
8	770	2771	3	73	384
6	507	1823	3	65	149
4	296	1067	3	51	44
2	122	437	3	35	17

Halton Windis DWE, 1500

Regulation	Air volume		HVC	Sound pressure level	Power consumption
[V]	[l/s]	[m ³ /h]	Position	[dB(A) 10 m ² sab	[W]
10	701	2523	1	76	502
8	567	2042	1	71	268
6	406	1461	1	63	104
4	235	847	1	50	31
2	106	381	1	32	12
10	695	2501	2	77	503
8	544	1960	2	71	268
6	380	1368	2	63	104
4	220	794	2	49	31
2	104	373	2	32	12
10	664	2389	3	77	503
8	512	1844	3	71	268
6	364	1310	3	63	104
4	245	882	3	49	31
2	97	349	3	32	12

Halton Windis DWE, 2000

Regulation	Air volume		HVC	Sound pressure level	Power consumption
[V]	[l/s]	[m ³ /h]	Position	[dB(A)] 10 m ² sab	[W]
10	929	3345	1	77	666
8	797	2869	1	73	384
6	535	1926	1	64	149
4	307	1107	1	51	44
2	130	469	1	34	17
10	929	3345	2	77	667
8	797	2869	2	73	383
6	517	1861	2	64	149
4	303	1091	2	51	44
2	123	444	2	34	17
10	929	3345	3	78	667
8	770	2771	3	73	384
6	507	1823	3	65	149
4	296	1067	3	51	44
2	122	437	3	35	17

Halton Windis DWE, 2500

Regulation	Air volume		HVC	Sound pressure level	Power consumption
[V]	[l/s]	[m ³ /h]	Position	[dB(A) 10 m ² sab	[W]
10	1285	4626	1	77	665
8	1045	3762	1	72	355
6	742	2671	1	64	137
4	380	1368	1	51	41.9
2	211	760	1	34	17
10	1234	4444	2	78	665
8	1008	3629	2	73	355
6	707	2544	2	64	138
4	371	1336	2	51	41.9
2	201	725	2	35	17
10	1138	4097	3	78	665
8	906	3262	3	73	355
6	657	2366	3	64	138
4	349	1255	3	51	41.9
2	201	725	3	36	17

Structure and materials

Fig. 2. Halton Windis DWE structure

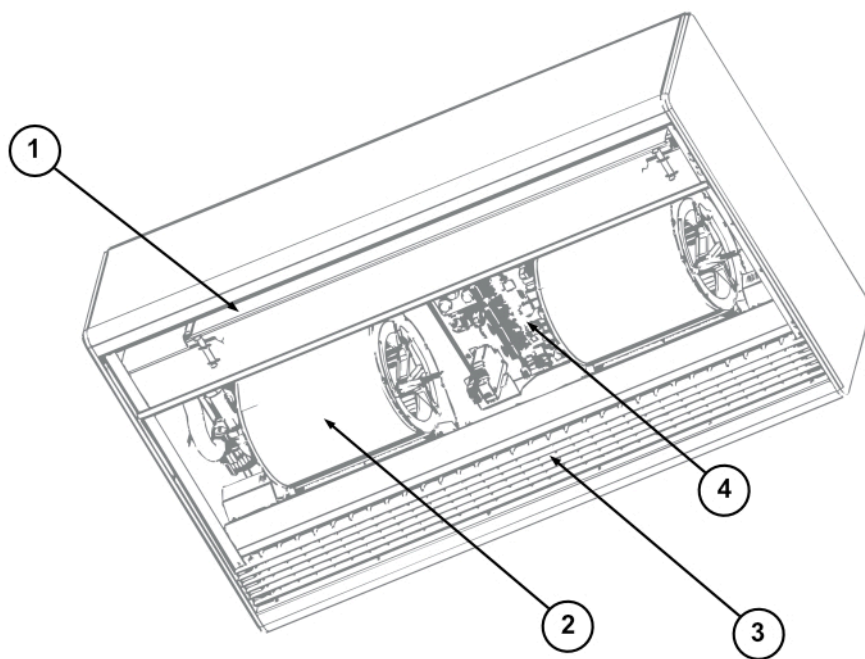

No.	Part	Description	Note
1	Filter	Aluminium	-
2	EC-fan	Metal	-
3	Outlet grille	Aluminium / Steel	-
4	Intelligent controller	-	-

Dimensions and weight

Fig. 3. Dimensions of Halton Windis DWE

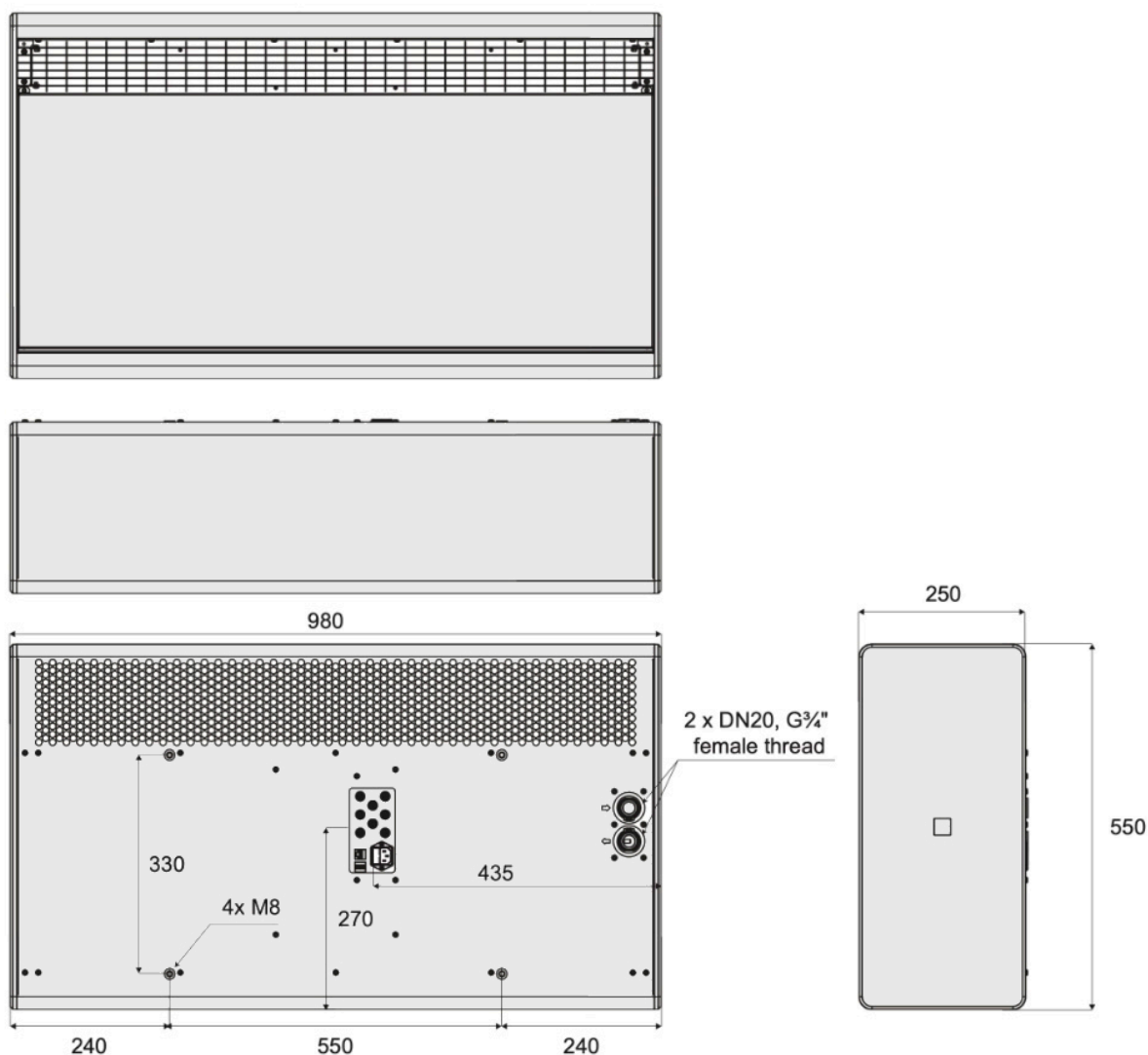

DWE	L [mm]	W [mm]	H [mm]	L1 [mm]	Weight [kg]
1000	980	250	550	435	46
1500	1480	250	550	435	60
2000	1980	250	550	435	79
2500	2480	250	550	435	95

Specifications

The Halton Windis DWE is an air curtain designed for exposed installation. The system features integrated thermal energy measurement using precise ultrasound technology, a smart controller with a built-in web server and ready Modbus and BACnet interfaces, and an adjustable blowing impulse to tailor specific needs.

Function

- Four product models equipped with integrated controls eliminate the need for additional controls on the walls and allow for a clean, streamlined design.
- Adjustable blowing speeds and an inbuilt schedule function for efficient management.
- Includes programmatic freeze protection and a Master-Slave function for synchronized operation.
- Integrated control valves and actuators, along with energy measurement, air bubble detection, and pressure measurement of the heating network.
- Featuring a counter for door openings, enhancing overall functionality.
- Supporting ECM engines and allows optimized operation for each building.
- Ready-to-implement graphic images simplify design processes.
- Functional changes to easily adapt to specific needs.

Structure

- Available in four different widths: 1000 mm, 1500 mm, 2000 mm, and 2500 mm.

Material

- The frame is painted with light grey RAL 7035 and the grill with graphite grey RAL 7024.
- The heating radiator system features 3/8" copper pipes with aluminium strips for enhanced heat dissipation and a G1" internal thread for secure connections. Designed to operate at a maximum pressure of 6 bar and a temperature of up to 100°C.
- The electrical connections include a 2 m power supply with safety grounding, a spark plug, and additional interfaces like an M12 connector, Ethernet, and USB.
- The fan is equipped with centrifugal blades and ball bearings for efficient and reliable operation.
- The system includes a 2-way heating valve, a heat energy meter, a G4 filter, adjustable blow impulse, and supports Modbus TCP, BacNet TCP, Modbus RTU, BacNet MSTP, and an I/O interface for connectivity.

Integrated controller

- The automation system of the door curtain unit provides significant advantages by ensuring all components are pre-tested and the control system operates as intended.
- The pre-tested control system adapts quickly to changing conditions, optimizing performance and energy efficiency in real time.
- This advanced controller integrates seamlessly with building automation systems via Modbus or BACnet interfaces. Network topology options include TCP/IP or RS-485, ensuring flexible and robust communication.
- It contains various integrated sensors for measuring air temperature, water-side energy meter, water pressure and freeze protection. Apart from these, external sensors can be connected.
- The controller can be integrated into the BMS, allowing all control signals to be managed directly through the BMS, except for the freeze protection function, which cannot be

bypassed.

Installation

Installation instructions covering installation options, space requirements, wiring and other installation requirements are available in a separate document.

See **Halton Windis DWE Installation and commissioning guide**.(preparation is in-progress and the link will be enabled when it is available)

Commissioning

Installation instructions covering installation options, space requirements, wiring and other installation requirements are available in a separate document.

See **Halton Windis DWE Installation and commissioning guide**.(preparation is in-progress and the link will be enabled when it is available)

Maintenance

Maintenance instructions are available in the **Halton Windis DWE user manual**. (preparation is in-progress and the link will be enabled when it is available)

Order code

DWE-M-L; VC-CO-ZT

Main options	
M = Model	
S	Small
L = Length [mm]	
	1000, 1500, 2000, 2500

Other options and accessories	
VC = Impulse force	
1	Position 1
2	Position 2
3	Position 3
CO = Colour	
TG	Grey
x	Special colour (RAL xxxx)
ZT = Tailored product	
N	No
Y	Yes (ETO)

Order code example
DWE-S-1500; VC=2, CO=TG ,ZT=N