

NEW! Halton Max MOS – Airflow management damper (VAV)

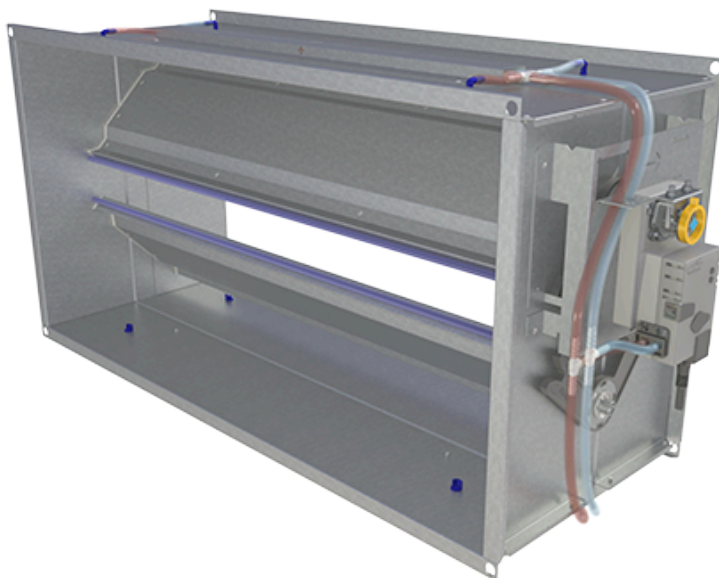

Overview

Halton Max MOS is a rectangular airflow management damper that needs no safety distances. This airflow management damper is also designed to function at very low air velocity.

It uses advanced and patented airflow measurement based on the combination of the blade opening and the pressure difference between the blades.

Application areas

- Variable (VAV) and constant (CAV) airflow control applications
- Supply and exhaust installations

Key features

- 0.5-8 m/s airflow velocity
- Maximum differential pressure: 500 Pa over the damper
- Can be connected to Building Management System (BMS)

Operating principle

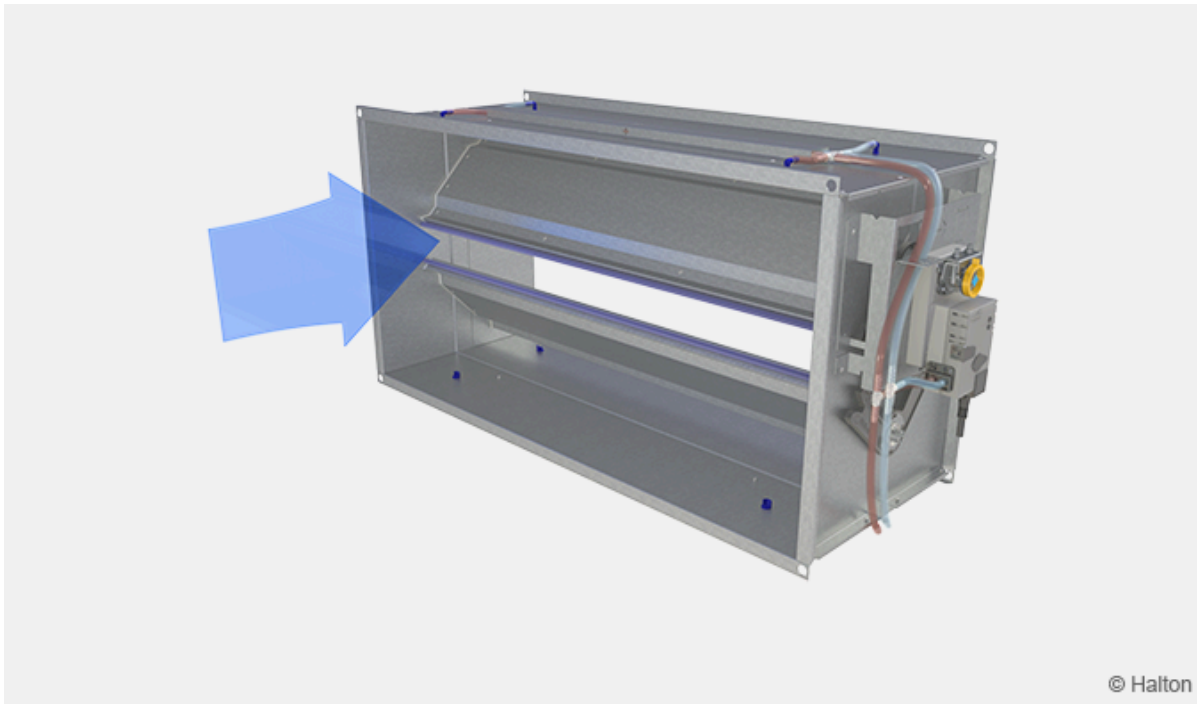

Fig. 1. Halton Max MOS measuring pressure difference between blades.

Thanks to short (<330mm) and smooth damper casing and uniquely positioned walled measurement probes therein, the flow measurement is based on amplified pressure difference of the damper which enables accurate ($\pm 10\%$) and undisturbed flow control even at low flow velocity ($\geq 0,5\text{m/s}$).

It also enables challenging flow conditions without the need for in-duct structures, which would cause unnecessary initial pressure losses and challenges for damper cleaning or additional duct sections for safety distance (0-distance). These would cause high additional costs and challenge for damper positioning and installation in other dampers. Also, eventual cleaning of the measurement probes may be done with pressurized air outside of the unit without the need to access measurement tubes or damper blades inside the damper.

Depending on the selected airflow controller, it can receive the airflow control signal via

- Modbus RTU network variable
- BACnet MSTP network variable
- An analog standard signal

The airflow setpoint can be modified between the minimum and maximum settings from the room controller interface or a BMS. The VAV controller can also send the actual value data back to the room interface controller. The communication protocol used for the signal between the room control interface and the VAV controller depends on the actuator model.

Key technical data

Features	Description
Duct connection sizes	200×150 mm up to 800×400 mm
Material	Galvanised steel or stainless steel (EN 1.4404/ AISI 316L)
Air velocity range	0.5 – 8 m/s
Operating range (ambient temperature)	0-50°C
Ambient relative humidity (non-condensing)	< 95%
Communication interface	Modbus RTU, BACnet MST, analog
Accessories	<ul style="list-style-type: none"> • Attenuator: several size and material options available • Reheat coil: models with or without internal heating controller available
Standards and certifications	<ul style="list-style-type: none"> • Building material declaration, declaration of conformity • Casing tightness EN 1751 class C • Shut-off operation tightness fulfils EN 1751 class 3
Maintenance	According to the building maintenance program

Features and options

Category	Feature (order code)	Option (order code)	Description
Size	Width of duct connection size W	200, 250, 300, 400, 500, 600, 800	Seven nominal width sizes. Units are in millimetres.
	Height of duct connection size H	150, 200, 250, 300, 400	Five nominal height sizes. Units are in millimetres.
Options	System package SP	N	No
	Material MA	GS	Galvanised steel
		AS	Stainless steel (EN 1.4404/AISI 316L)
	Insulation IN	NA	No insulation material on the damper body
		I3	Damper body is insulated with 50 mm mineral wool (see Fig.2.)
	Control unit CU	EX	Control unit with analog signal (0...10V or 2...10V)
		EY	Control unit with Modbus RTU or BACnet MSTP
	Factory-set airflow limits FS	DC	Customer specific settings
		DS	Default factory settings (Vnom)
Transformer TF	NA	Not assigned	
	TF1	230/24 transformer (35V)	
Sound attenuator, SA (subproduct*)	Sound attenuator material AT	W	Mineral wool
		P	Polyester fibre

Reheater, RH (subproduct*)	Model type RT	E	Electrical heater
		W	Water coil for heating or cooling
	Control type, electrical RE	NA	Not assigned
		1	Own room panel to adjust setpoint and measure temperature
		2	On/off controller, need external controller to switch heater on or off
		3	External 0-10V control signal to adjust heating element power
	Control type, water RW	4	External PWM control signal to adjust heating element power
		NA	Not assigned
		H	Coil for heating
		C	Coil for heating or cooling. Drip tray included.

* Ordered separately

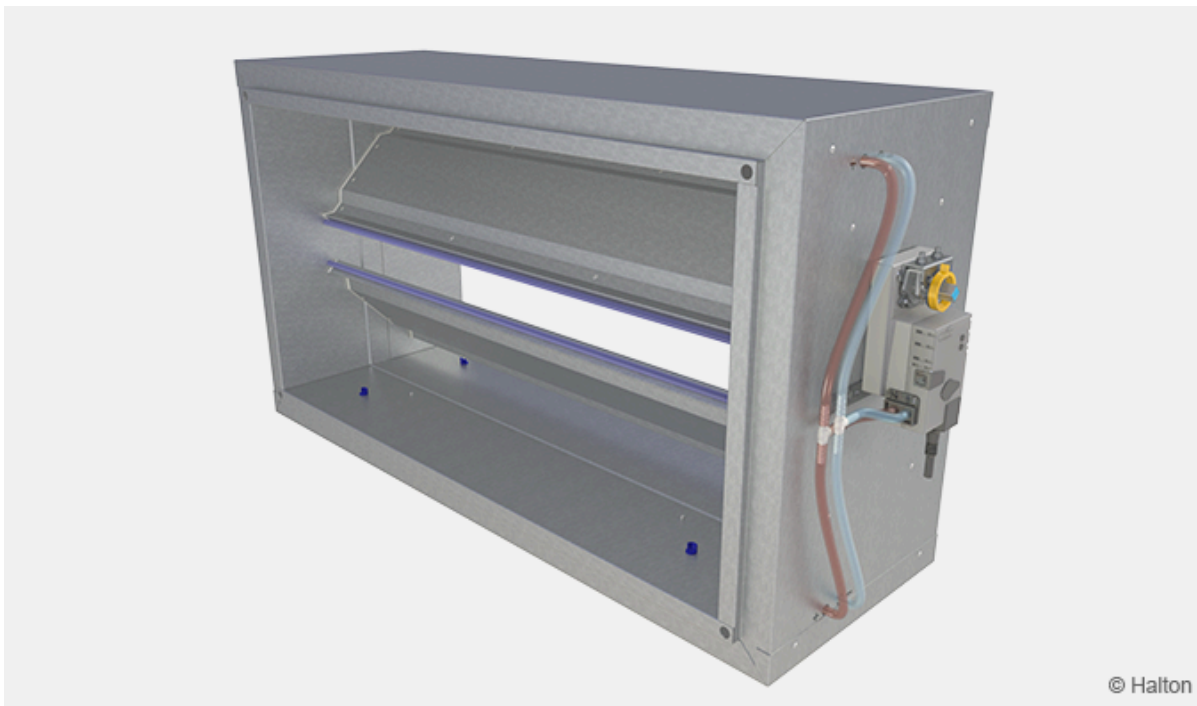

Fig. 2. Halton Max MOS, insulated model (IN=I3).

Control units

A range of control units are available for various application needs.

The control unit includes an integrated dynamic differential pressure sensor. The pressure sensor has a low bypass airflow rate through the sensor element. Depending on the model, airflow rate limits are adjusted on site with a mobile application or a dial for manual adjustment.

Code	Actuator	Torque	Damper size	Communication interface	Order code
EX	Belimo	10 Nm	200 x 150 – 800 x 400	Analog 0..10V/2..10V	EX = NMVD3W- MP.1 (DC 0/2...10 V), 10 Nm
EY	Belimo	10 Nm	200 x 150 – 800 x 400	Bus Modbus RTU BACnet MSTP	EY = NMVD3W- MOD.1 (Modbus RTU/ BACnet MSTP), 10 Nm

Quick selection

The operable airflow range for the Halton Max MOS corresponds to the duct air velocities of 0.5-8 m/s.

		Operating range [l/s]						
Width [mm]		200	250	300	400	500	600	800
Height [mm]	150	15-240	19-300	23-360	30-480	38-600	45-715	–
	200	20-320	25-400	30-480	40-640	50-800	60-960	80-1280
	250	–	31-500	38-600	50-800	63-1000	75-1200	100-1600
	300	–	–	45-664	60-948	75-1200	90-1440	120-1920
	400	–	–	–	80-1280	100-1600	120-1920	160-2560

Table 1. Operating range, min – max [l/s]

Width [mm]		Operating range [m ³ /h]						
		200	250	300	400	500	600	800
Height [mm]	150	54-864	68-1080	81-1296	108-1728	135-2160	162-2574	–
	200	72-1152	90-1440	108-1728	144-2304	180-2880	216-3456	288-4608
	250	–	113-1800	135-2160	180-2880	225-3600	270-4320	360-5760
	300	–	–	162-2390	216-3413	270-4320	324-5184	432-6912
	400	–	–	–	288-4608	360-5760	432-6912	576-9216

Table 2. Operating range, min – max [m³/h]

Structure and materials

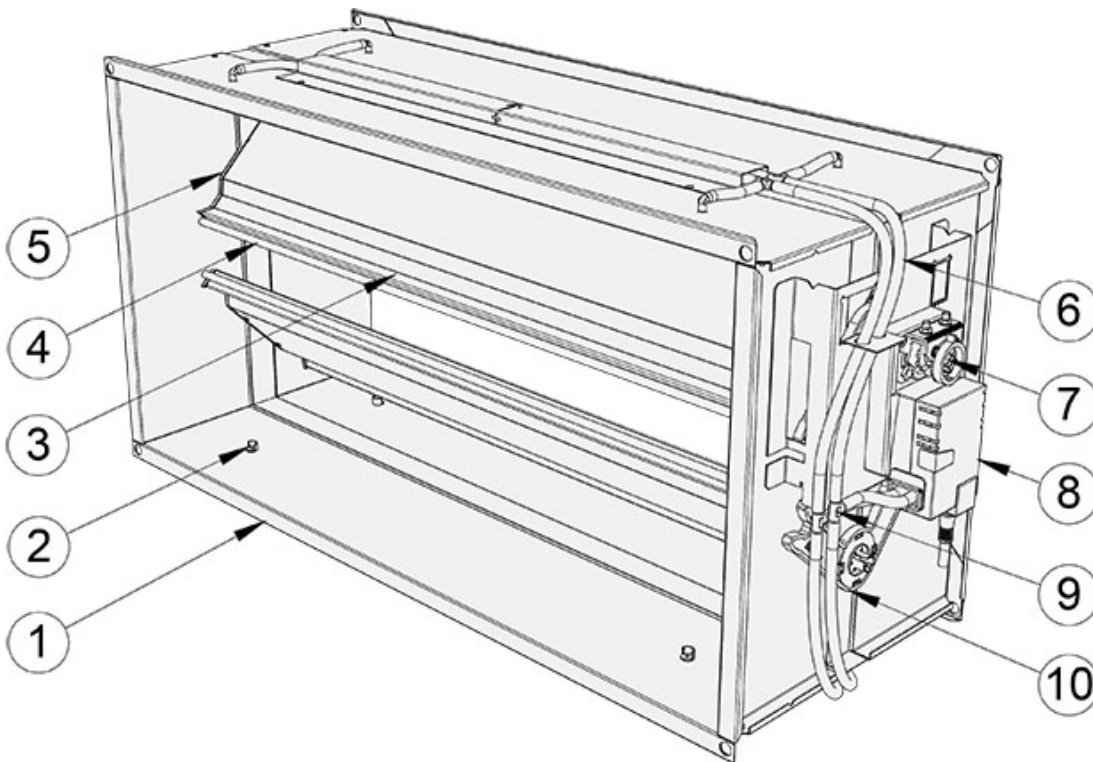

Fig. 3. Structure of Halton Max MOS

No.	Part	Description	Note
1	Casing	Galvanised steel	Stainless steel (EN 1.4404/ AISI 316L) also available.
2	Measurement probe	Polyurethane	–
3	Blade	Galvanised steel	Sandwich design. Stainless steel (EN 1.4404/AISI 316L) also available.
4	Blade gasket	Silicone	Heat-proof model: LTE silicone
5	Blades end gasket	Silicone	–
6	Measurement tube	Silicone	–
7	Rectangular drive shaft	Stainless steel (<i>AISI 316L</i>)	12×12 mm
8	Control unit	Plastic, steel	PVC cable
9	Tube connector	Plastic	POM
10	Gear sector	Plastic	–

Dimensions and weight

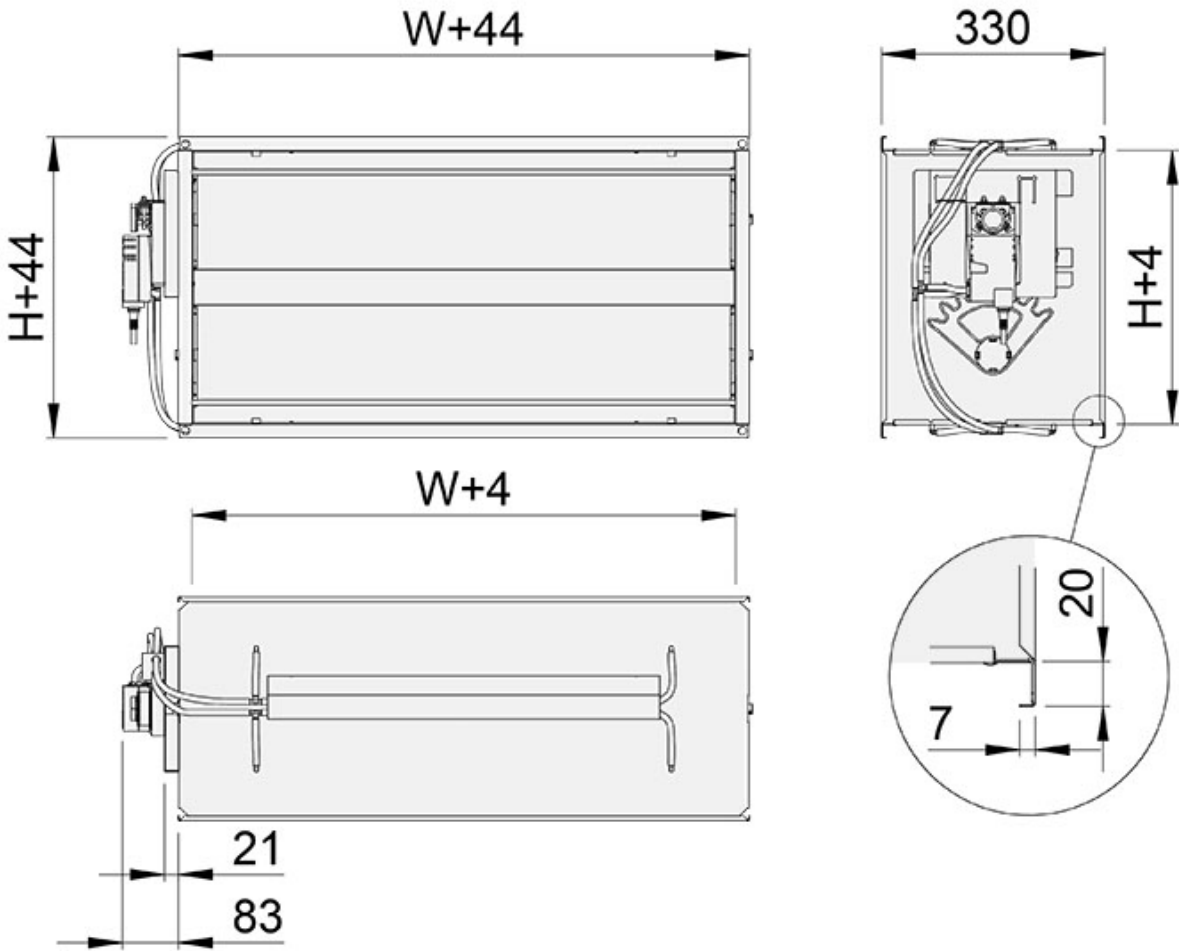

Fig. 4. Dimensions of Halton Max MOS

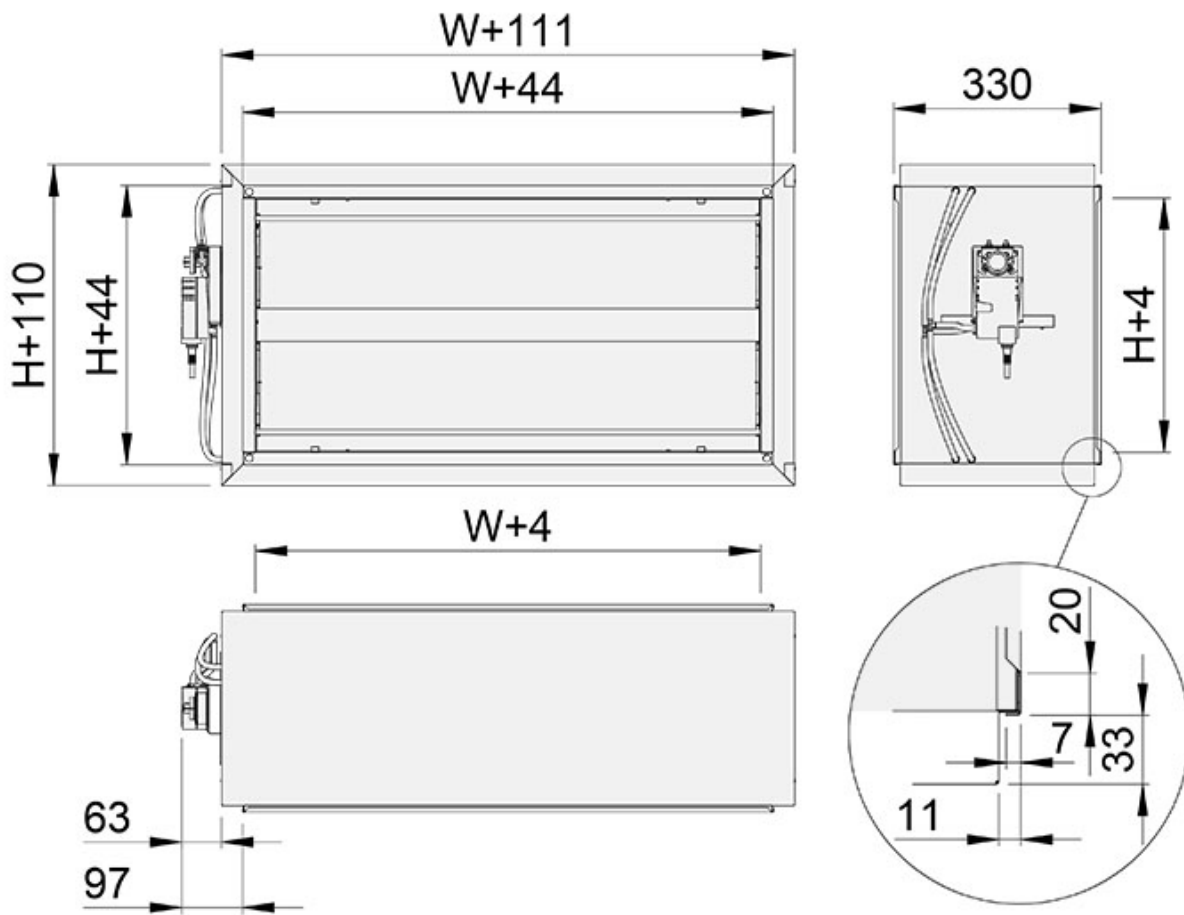

Fig. 5. Dimensions of Halton Max MOS, insulated model

WxH [mm]	Weight [kg]	Weight, insulated [kg]
200×150	4.0	6.4
200×200	4.4	7.0
250×150	5.4	8.1
250×200	4.7	7.6
250×250	5.1	8.3
300×150	4.8	7.6
300×200	5.2	8.3
300×250	5.7	9.0
300×300	6.3	9.9
400×150	5.5	8.7
400×200	6.0	9.4
400×250	6.5	10.2
400×300	7.4	11.4
400×400	8.4	13.0
500×150	6.2	9.9
500×200	6.8	10.6
500×250	7.3	11.5
500×300	8.3	12.8
500×400	9.5	14.5
600×150	6.8	11.0
600×200	7.4	11.7
600×250	8.0	12.6
600×300	9.0	13.9
600×400	10.2	15.7
800×200	9.3	14.5
800×250	9.9	15.4
800×300	11.3	17.0
800×400	12.9	19.1

Specification

Rectangular pressure-independent variable multiblade airflow control damper for supply and exhaust installations, fulfilling the following requirements:

Construction

- Short (<330mm) and smooth damper casing and uniquely positioned walled measurement probes therein.
- The flow measurement is based on amplified pressure difference of the damper. Accurate ($\pm 10\%$) and undisturbed flow control even at low flow velocity ($\geq 0,5\text{m/s}$) and challenging flow conditions. Control range at least 1:15
- Closed damper blade air leakage according to EN 1751 class 3.
- Casing air leakage according to EN 1751 class C.
- No internal structures that would cause unnecessary initial pressure losses and challenges for damper cleaning. Eventual cleaning of the measurement probes to be done with pressurized air outside of the unit without the need to access measurement tubes/vanes or damper blades inside the damper.
- No need to install additional duct sections for safety distance (zero safety distance).

Material

- Galvanised or stainless steel (EN 1.4404, AISI 316L)

Electrical data

- Modbus RTU, BACnet MSTP, or analogue connection
- Control signal range of analogue control mode is for input 0...10 VDC or 2 ...10 VDC
- Feedback signal range of analogue control mode for output follows the selected control signal range 0...10 VDC
- Power supply voltage 24 V DC/AC

Parameter settings

- Designed airflow range can be set at the factory.
- Controller settings are adjustable on site with bus communication or external service tool.

Accessories

- Sound attenuator for noise reduction. Model with access panel available for easy maintenance.
- Electric reheat coil with an internal heating controller.
- Water coil for heating and cooling

Order code

MOS-W-H; SP-MA-IN-CU-FS-TF-ZT

Main options	
W = Width of duct connection [mm]	200, 250, 300, 400, 500, 600, 800
H = Height of duct connection [mm]	150, 200, 250, 300, 400

Other options and accessories	
SP = System package	
N	No
MA = Material	
GS	Galvanised steel
AS	Stainless steel (EN 1.4404/AISI 316L)
IN = Insulation	
NA	Not assigned
I3	Insulated, 50 mm
CU = Control unit	
EX	NMV-D3W-MP.1 (DC 0/2...10V), 10 Nm
EY	NMV-D3W-MOD.1 (Modbus RTU/BACnet MSTP), 10 Nm
FS = Factory-set airflow limits	
DC	Customer specified settings
DS	Default factory settings (Vnom)
TF = Transformer	
NA	Not assigned
TF1	230/24 transformer (35V)
ZT = Tailored product	
N	No
Y	Yes (ETO)

Sub products and accessories (ordered separately)	
SA	Sound attenuator
RH	Reheat coil

Order code example

MOS-400-200; SP=N, MA=GS, IN=NA, CU=EX, FS=DS, TF=TF1, ZT=NA

Installation

The Halton Max MOS airflow control damper can be installed to T-branch and curve, without safety distances. The accuracy of the measured airflow is given in a table below. Install the unit into the ductwork in such a way that the airflow direction through the unit is as indicated with the arrow label in the unit casing.

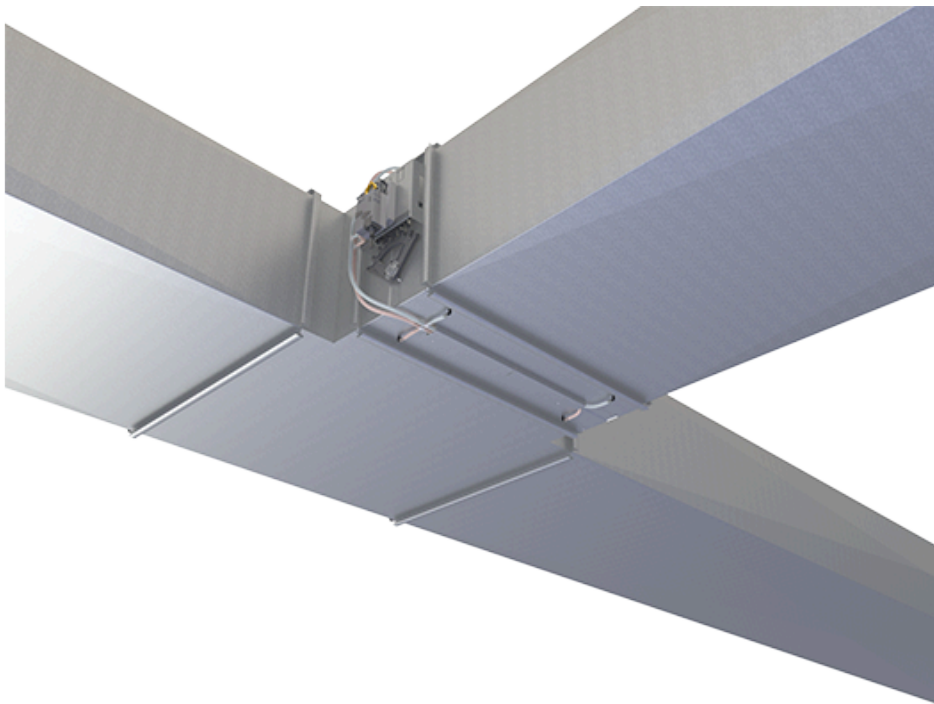

Fig. 6. Example of Halton Max MOS installed to duct with no safety distances

Technical performance

- Velocity range 0.5– 8.0 m/s
- General Measurement Uncertainty
 - Accuracy $\pm 10\%$
 - The minimum allowed safety distance is $0 \times D$.

Note: The measurement uncertainty is defined in laboratory conditions and may be greater in practical installations, where non-optimal installation situations or multiple consequent disturbances may exist.

Wiring

The wiring must only be carried out by qualified personnel following the local regulations. For the

power supply, a safety isolating transformer must be used.

The bus must be implemented according to standard EIA/TIA-485.

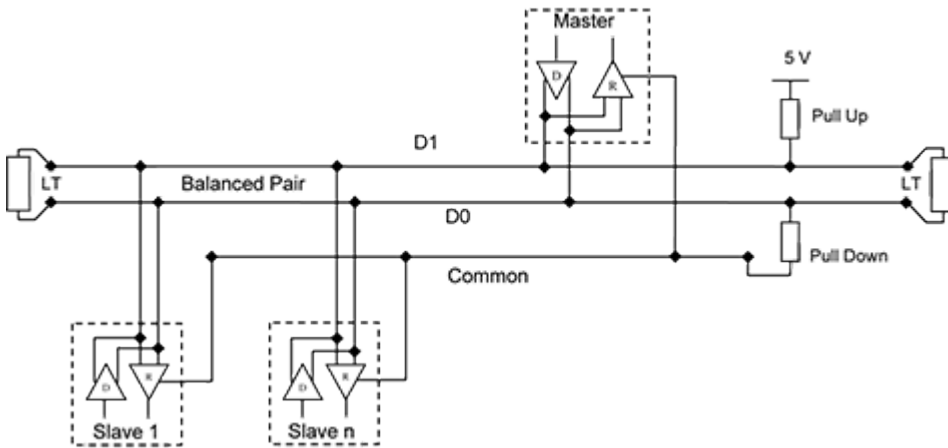

Fig. 6. Example: General RS-485 2-wire Topology

For connection and wiring diagrams, see Controller connections and Wiring diagrams in Technical reference data.

Cabling requirements

Field devices:

- The wires connected to the terminals have a cross-sectional area of at least 0.5 mm^2 .
- Twisted-pair cables, shielding recommended.

Modbus RTU or BACnet MSTP cable:

- Shielding twisted-pair. For example, Belden 3105A or Nomak $2 \times 2 \times 0.5 + 0.5$.
- Max. bus length 1000 m.
- To avoid signal reflections, a 120 Ohm termination resistance must be added at the end of the main cable line.

Commissioning

Airflow control

The airflow rates for the Halton Max MOS are preset at the factory. If the airflow rates are not specified by the customer, the default factory settings are 0 for the minimum airflow rate and the nominal value (V_{nom}) for the maximum rate.

The nominal airflow rates in the following table are given with a pressure level of 200 Pa.

		Vnom [l/s]						
Width [mm]		200	250	300	400	500	600	800
Height [mm]	150	275	330	385	495	605	715	–
	200	386	478	570	754	937	1121	1488
	250	–	500	605	815	1026	1236	1657
	300	–	–	664	948	1232	1516	2084
	400	–	–	–	1452	1817	2182	2912

Table 3. Vnom [l/s]

		Vnom [m ³ /h]						
Width [mm]		200	250	300	400	500	600	800
Height [mm]	150	990	1188	1386	1782	2178	2574	–
	200	1390	1721	2052	2714	3373	4036	5357
	250	–	1800	2178	2934	3694	4450	5965
	300	–	–	2390	3413	4435	5458	7502
	400	–	–	–	5227	6541	7855	10483

Table 4. Vnom [m³/h]

The actual airflow rate is calculated as a function of different of differential pressure at the measurement probe, blade opening angle and the correct size k factor.

Maintenance

The product is easy to maintain. Normally, the electrical parts do not need maintenance. It is recommended to clean the internal parts of the product when cleaning the ductwork. Refer to the building maintenance program for the maintenance cycle.

Design examples

Office room design example

Description

Office environments place high demands on the ventilation and air quality. Halton Max MOS is perfect for air management in spaces where wide airflow ranges are needed. Silent ventilation

system guarantees good working conditions. Minimum maintenance needs prevent creating disturbances in the daily activities.

Design data

- Office/meeting room area 14 m²
- Room minimum airflow 30 l/s
- Room maximum airflow 60 l/s
- Cooling load 500W, 36W/m²

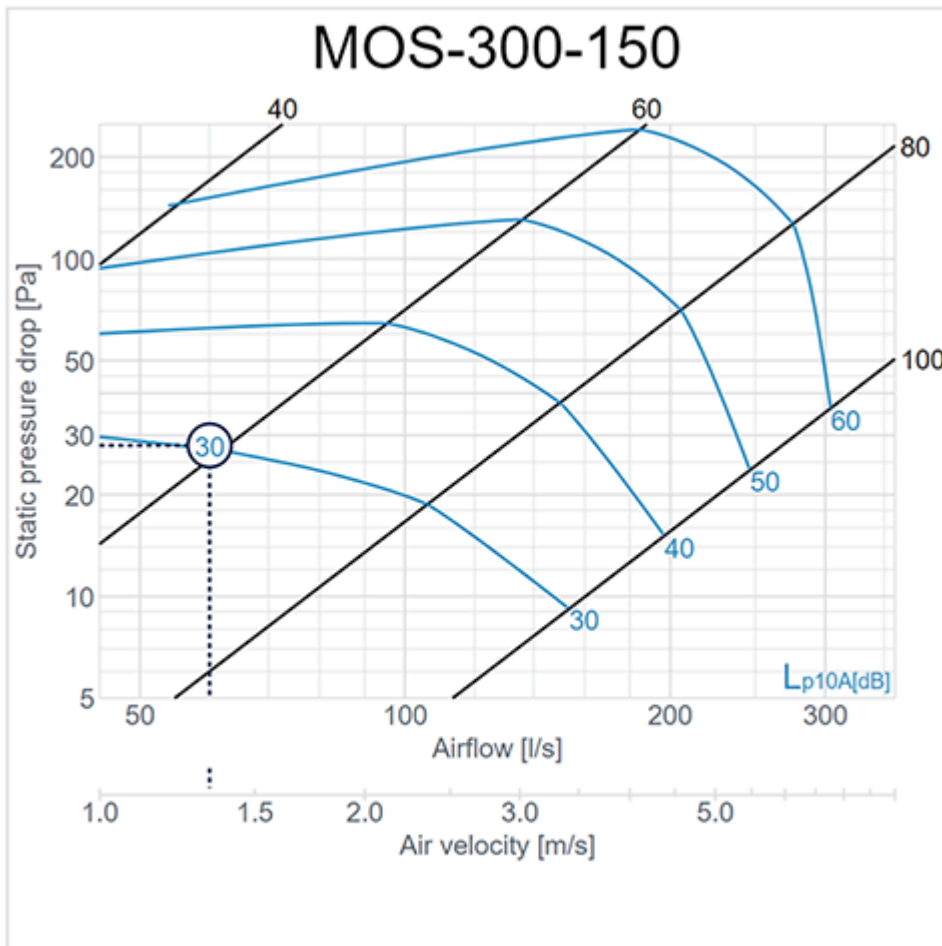

Fig. 7. Halton Max MOS performance

Ventilation design

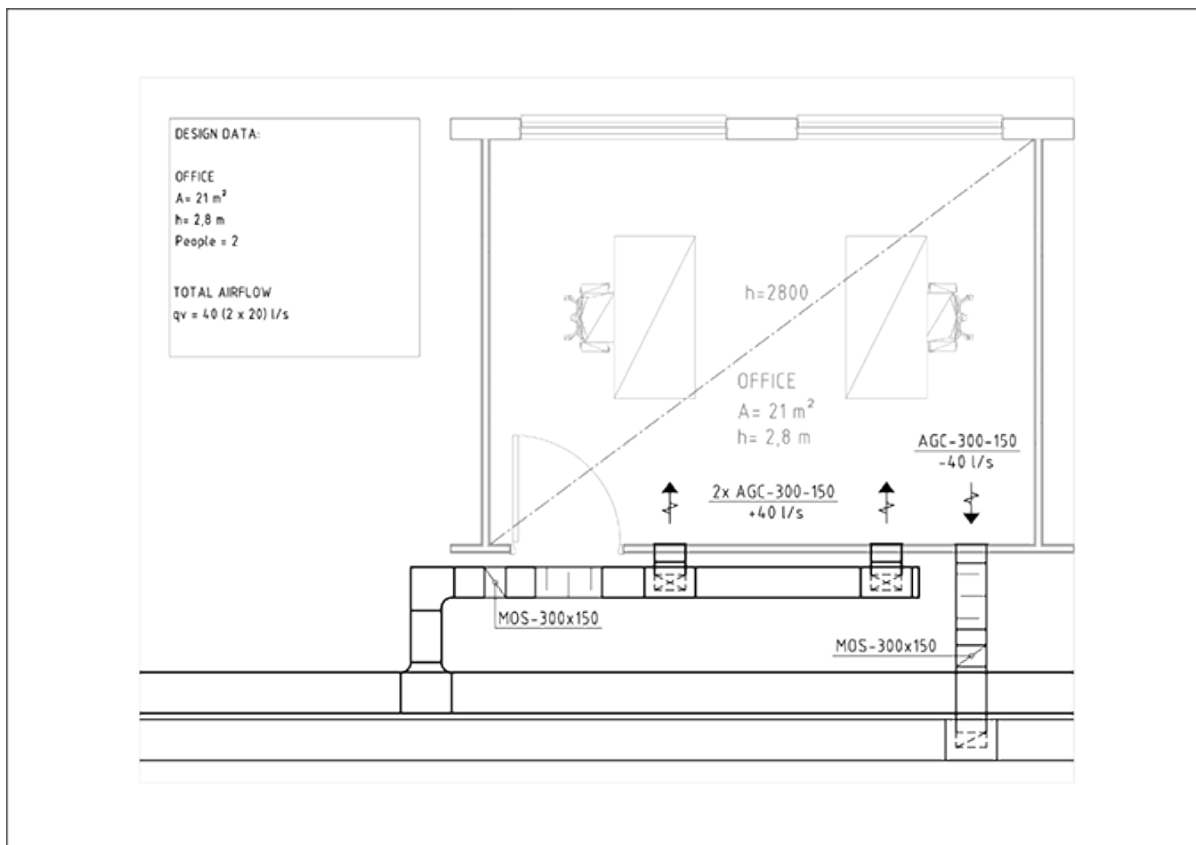

Fig. 8. Halton Max MOS ventilation design

Components

- MOS with attenuator 600 length
- AGC-500-100
- PRL/F-500-100-200
- 2 x JDS/S-160

Schematic drawing

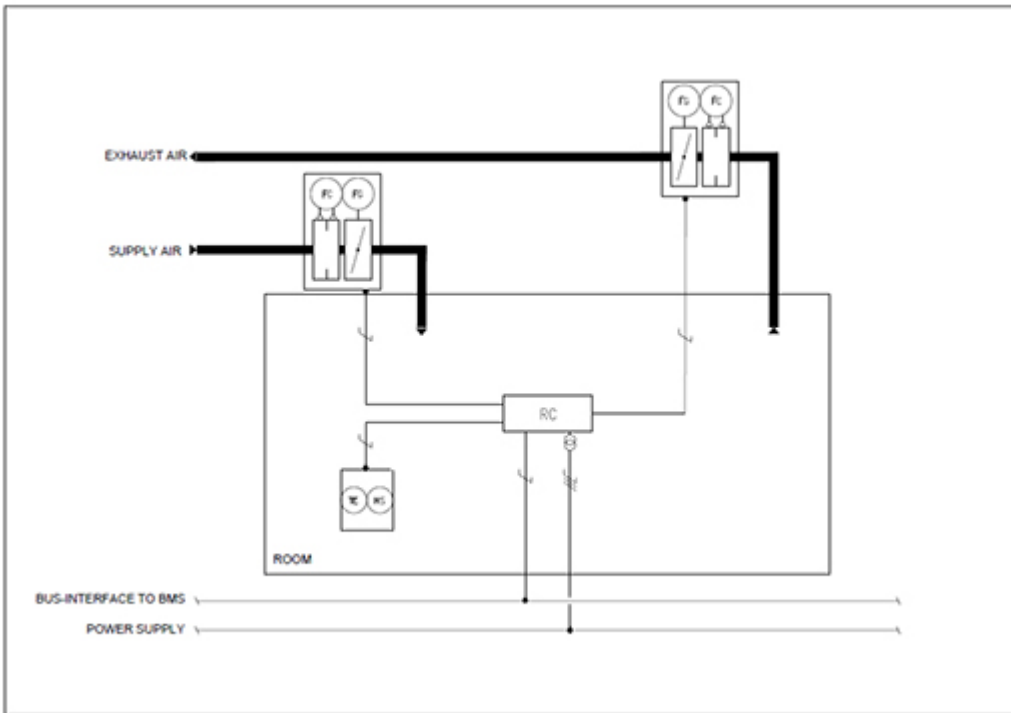

Fig. 9. Wiring example for Halton Max MOS with a master-slave configuration

In this example, the supply unit is controlling the exhaust unit.

Accessories

Reheat coils (RH)

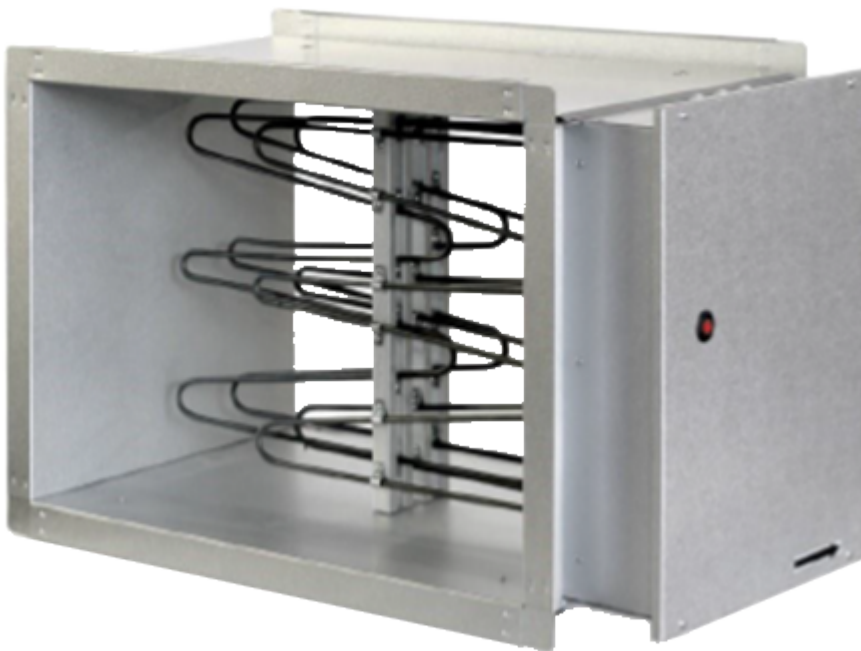

Fig. 10. Rectangular duct heater, electrical

Halton offers two models of reheater for ducts:

- Water heater/cooler coils are designed for cooling the ventilation air in a ventilation system. The reheater/cooler can also be used for heating or cooling individual rooms or zones.
- Electrical heaters, circular and rectangular, are designed to heat fresh air in a ventilation system.

For more information on the available reheat coils, see section Downloads.

Sound attenuators (SA)

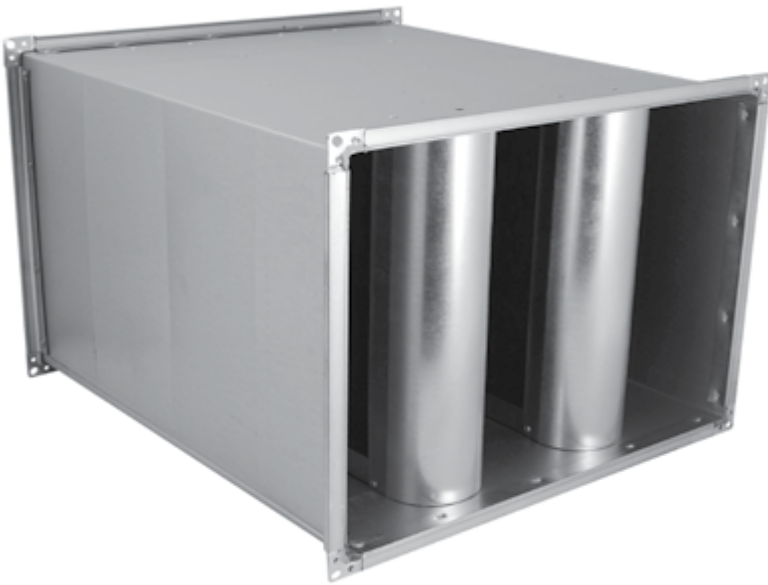

Fig. 11. Rectangular sound attenuator

Halton offers high-quality rectangular and circular sound attenuators for reducing noise levels in the duct.

For more information on the available sound attenuators, see section Downloads.