

# Halton Jaz JSC – Nozzle diffuser



## Overview

Halton Jaz JSC is the perfect choice for several different applications ranging from workplaces to hospitals, thanks to its high mixing effect. This square diffuser is available with three different front plate models, each with a different amount of nozzles and designed for specific airflow requirements.

## Application area

- Ventilation in offices, hospital rooms, schools, and public spaces

## Key features

- Adjustable nozzles
- Silent function also with large airflows
- Adjusting and measuring with Halton Pop PDI balancing plenum
- Ceiling adapters available for different ceiling types

# Operating principle

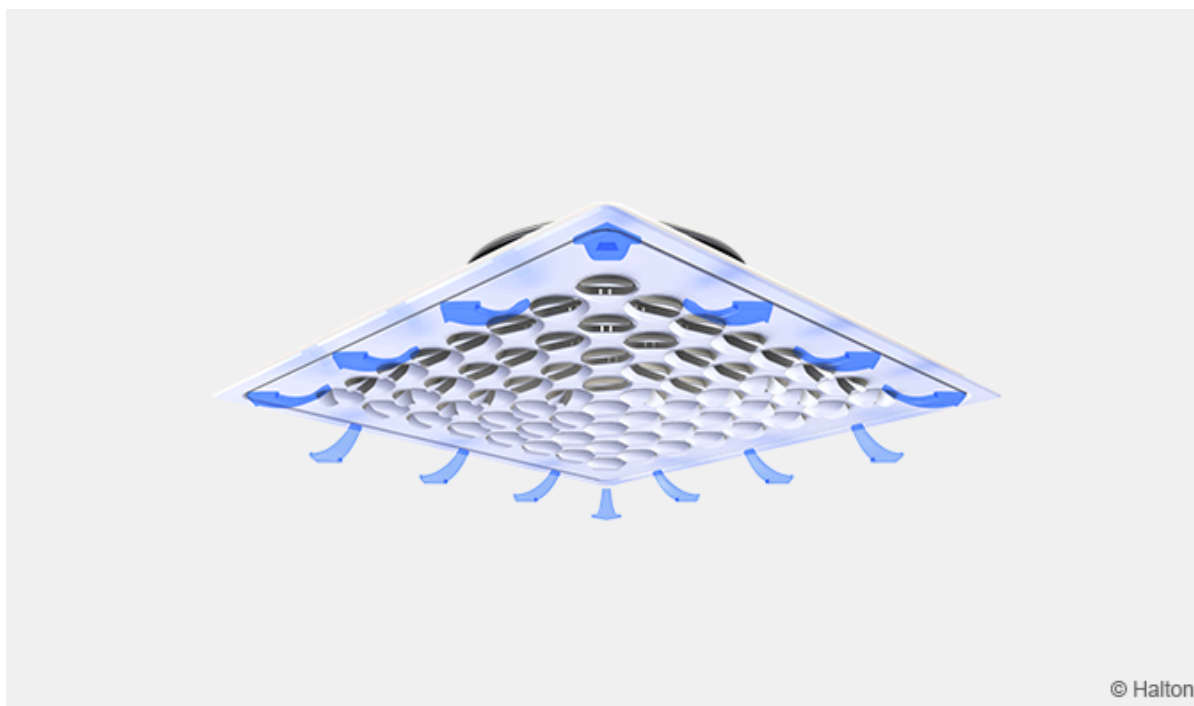

**Fig. 1.** Operating principle of Halton Jaz JSC

Air is supplied into the space through the nozzles of the front panel. The two-channel design of the nozzles allows silent operation and high induction rate.

The throw pattern of the diffuser can be adjusted by turning nozzles to the desired direction. By default, the nozzle pattern is 4-directional. Other often used patterns are 3-, 2-, 1 ways, but the custom patterns are also possible thanks to the individually adjustable nozzles. The direction of the supply air jet has no effect on the noise level, pressure drop or airflow rate.

The recommended maximum temperature difference between the supply and room air is 10 °C.

## Key technical data

Feature	Description
Airflow rate	Max. airflow rate 162 l/s or 580 m <sup>3</sup> /h, <35 dB
Dimensions	595 x 595 mm or 420x420 mm
Weight	2.0 – 4.4 kg
Adjustability	Individually adjustable nozzles

# Features and options

Category	Feature (order code)	Option (order code)	Description
Diffuser	Duct connection size (D)	125, 160, 200, 250 or 315	Five nominal duct connections sizes. Units are in millimetres.
	Diffuser size (A)	420	420x420x50 mm. Available with duct connection sizes 125, 160 or 200.
		600	595x595x70 mm. Available with all duct connection sizes.
Balancing plenum PDI (subproduct <sup>*</sup> )	Model (M)	S	With supply airflow adjustment and measurement module MSM
		E	With exhaust airflow adjustment module MEM
		N	Without airflow adjustment module
	Sizes	D	Plenum's duct connection size. It can be either the same or one size bigger than diffusers duct connection.
		E	Diffuser connection size. Must be the same size than diffusers duct connection size.
	Sound attenuation material (AT)	P	With polyester attenuation material
		W	With mineral wool attenuation material
		NA	Without attenuation material
	Ceiling adapter CA for 420x420 diffusers (accessory <sup>*</sup> )	Model (M)	S1
H1			Hidden grid Ecophon Focus DS, Rockfon X
P1			Partly hidden grid Ecophon Focus Dg, Rockfon X
C1			Clip-in Dampa clip-in, square edge
R1			Recessed Ecophon Focus F, Rockfon E, T24

\* Orderd separately

## Quick selection

Values with adjustment module (MSM) fully open.

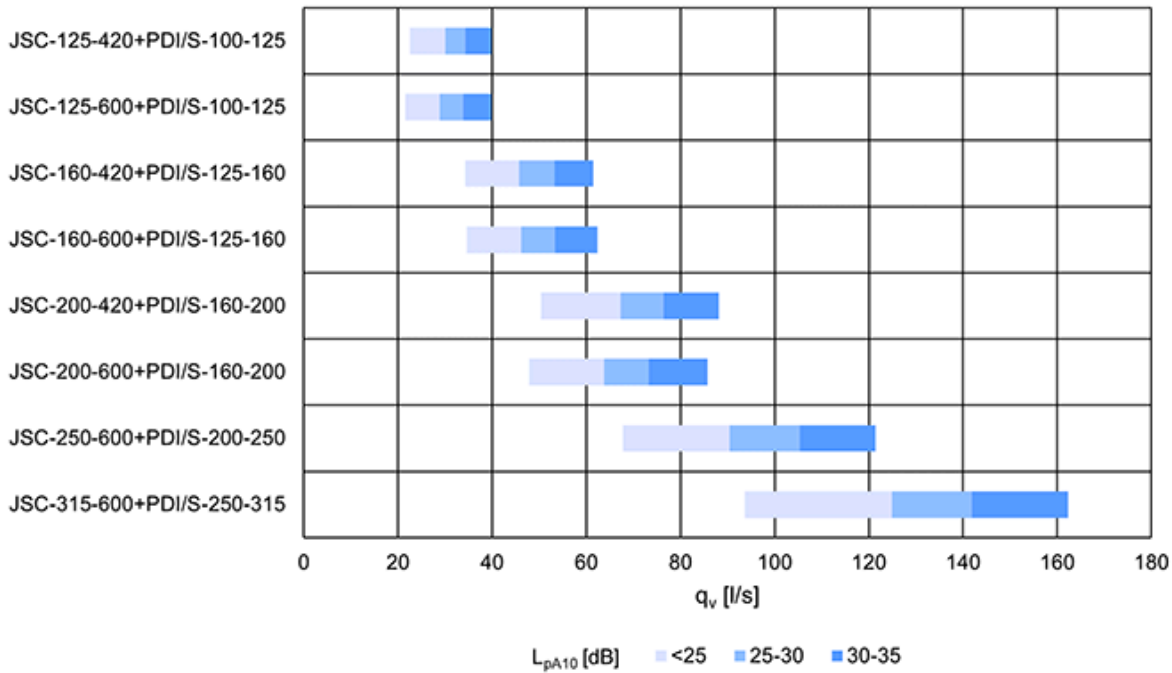

Fig. 2. Quick selection with unit l/s

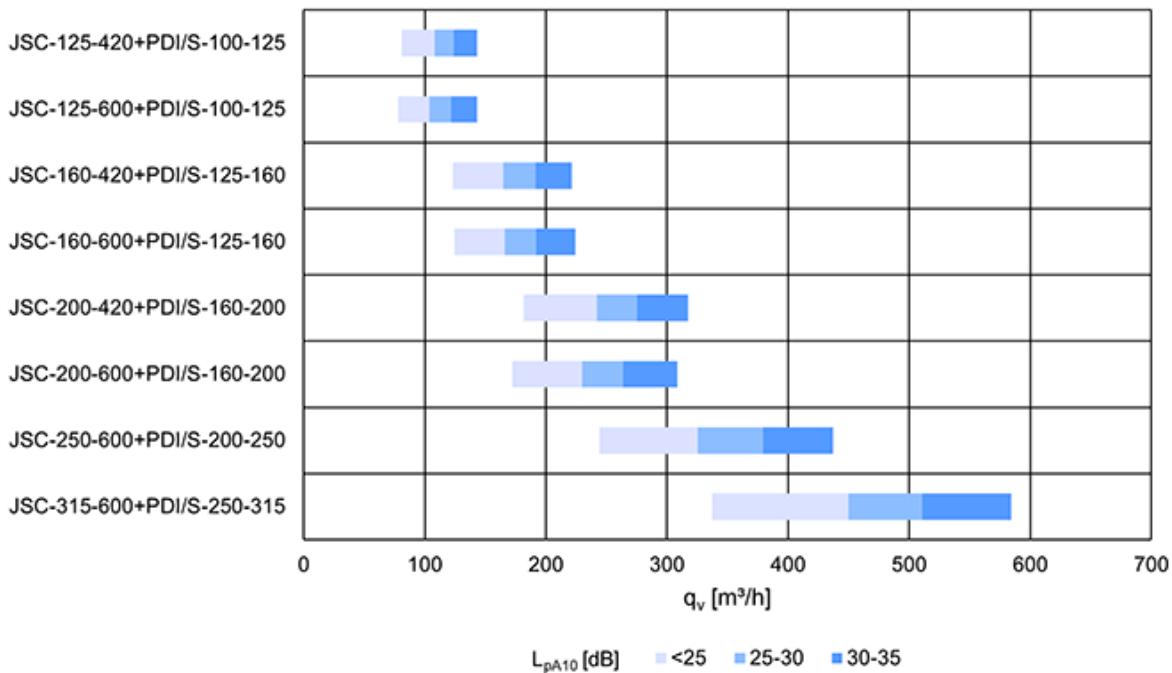
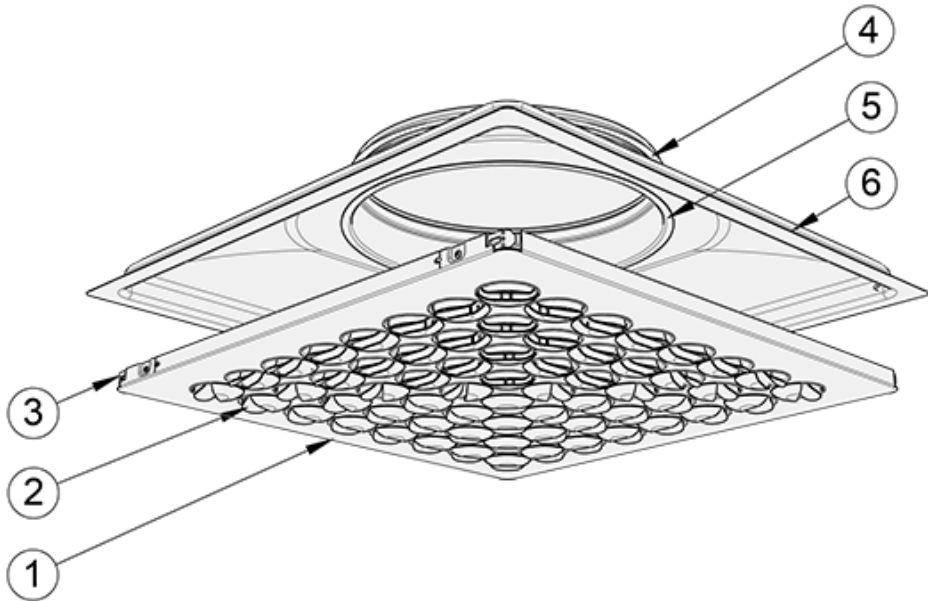

Fig. 3. Quick selection with unit m<sup>3</sup>/h

# Structure and materials



No.	Part	Description	Note
1	Front panel	Polyester-painted steel, white (RAL 9003/30%)	Special colours available
2	Nozzles	Plastic, polyacetal (POM)	Colour alternatives: white, black and grey
3	Front panel springs	Stainless steel	–
4	Duct seal gasket	Polymer	–
5	Spigot	Galvanised steel	–
6	Casing	Polyester-painted steel, white (RAL 9003/30%)	Special colours available

# Dimensions and weight

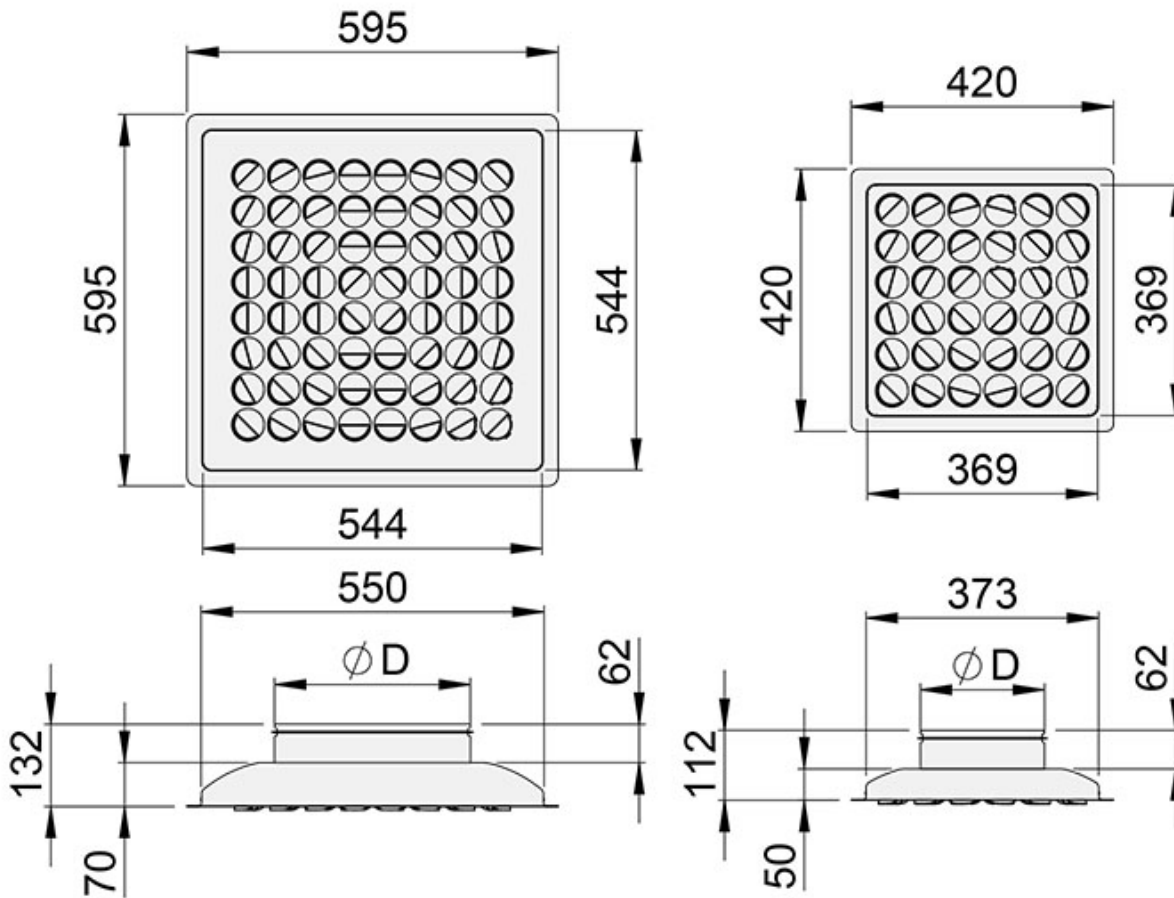
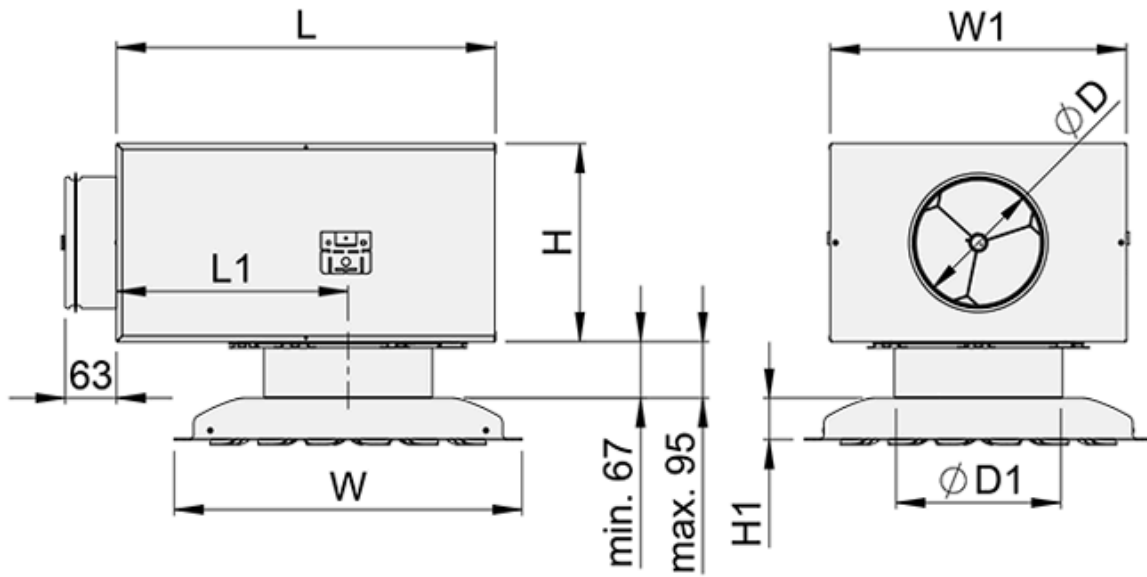

Fig. 4. Dimensions of Halton Jaz JSC diffuser, 600×600 mm (left) and 420×420 mm (right)

JSC	øD [mm]	Number of nozzles	Weight [kg]
125-420	125	16	2.0
160-420	159	36	2.1
200-420	199	36	2.2
125-600	124	16	4.4
160-600	159	36	4.4
200-600	199	36	4.0
250-600	249	64	4.1
315-600	314	64	4.2

## Halton Jaz JSC with Halton Pop PDI plenum



*Fig. 5. Halton Jaz JSC with Halton Pop PDI plenum, externally positioned connection spigot*

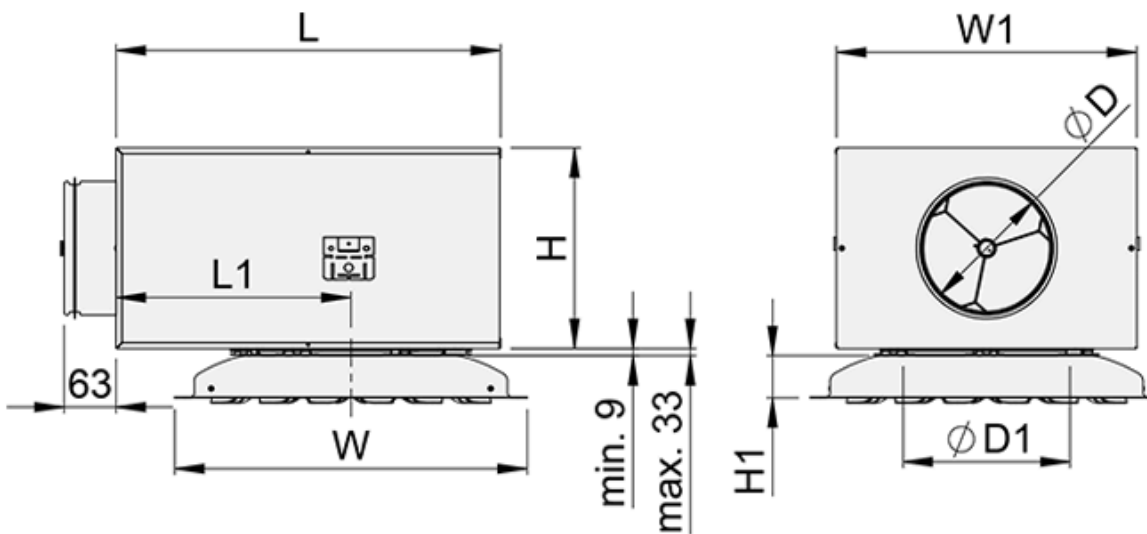

*Fig. 6. Halton Jaz JSC with Halton Pop PDI plenum, internally positioned connection spigot*



JSC	W [mm]	PDI	ØD [mm]	ØD1 [mm]	L [mm]	W1 [mm]	H [mm]	H1 [mm]	L1 [mm]	Weight [kg]
125-420	420	100-125	99	127	308	282	172	50	168	4.7
	420	125-125	124	127	308	282	172	50	168	4.8
160-420	420	125-160	125	162	308	282	172	50	168	4.8
	420	160-160	159	162	458	358	239	50	280	7.1
200-420	420	160-200	159	202	458	358	239	50	280	7.1
	420	200-200	199	202	458	358	239	50	280	7.2
125-600	595	100-125	99	127	308	282	172	70	168	7.1
	595	125-125	124	127	308	282	172	70	168	7.2
160-600	595	125-160	124	162	308	282	172	70	168	7.1
	595	160-160	159	162	458	358	239	70	280	9.4
200-600	595	160-200	159	202	458	359	239	70	280	8.9
	595	200-200	199	202	458	359	239	70	280	9.0
250-600	595	200-250	199	252	458	359	239	70	280	9.0
	595	250-250	249	252	520	480	359	70	280	12.3
315-600	595	250-315	249	317	520	480	359	70	280	12.2
	595	315-315	314	317	520	480	359	70	280	12.4

## Specification

Square nozzle diffuser for false ceiling installation, fulfilling the following requirements:

### Structure

- Front panel openable and removable to allow general maintenance and cleaning.
- Front panel removable without special tools.
- Four directional air distribution.
- Individually adjustable nozzles to change air distribution upon need.
- Two-slot nozzle design to ensure efficient air mixing and silent operation.
- Unit sizes:
  - 595×595 mm, height 70 mm
  - 420×420 mm, height 50 mm
- Inlet duct diameter 125, 160, 200, 250 or 315 mm.

## Materials

- Casing and front panel manufactured from steel.
- Casing and front panel white, powder painted in RAL 9003, 30 % gloss.
- Connection spigot manufactured from galvanized steel.
- Connection spigot equipped with a fixed gasket.

## Model with balancing plenum

- Diffuser to be connected with a galvanised steel plenum Halton Pop PDI.
- Plenum has an integrated gasket to ensure airtight duct connection.
- Plenum has a removable adjustment module MSM for supply or MEM for exhaust.

## Packaging and identification

- The product is protected by a removable plastic coating.
- The product is packed in a cardboard box.
- The product is identified by labels attached both to the product and the cardboard box.

## Installation



**Fig. 7.** Halton Jaz JSC connected to a Halton Pop PDI plenum

The diffuser is connected usually to balancing plenum Halton Pop PDI (Fig. 7). Alternatively, it can be connected direct to the duct by riveting or screwing. In that case, minimum safety distance to the next T-branch or curve is three times the duct diameter (3xD).



**Fig. 8.** Halton Jaz JSC, 420 with 595×595 mm ceiling adapter (CA)

## Commissioning



**Fig. 9.** Adjustment of airflow of diffuser and plenum combination

## Airflow control

The diffuser itself has no airflow adjustment. To adjust and measure the supply airflow rate, the diffuser shall be combined with Halton Pop PDI balancing plenum with measurement and adjustment module MSM. In case of exhaust air, use of adjustment module MEM is recommended. It

is not possible to measure exhaust airflow rate with adjustment module MEM.

Open the front plate and pass the tubes and control spindle through the front panel (*Fig. 9*). Replace the front panel. Measure the differential pressure with a manometer. The flow rate is calculated using the formula below:

$$q_v = k\sqrt{\Delta p_m}$$

where

- $q_v$       Airflow rate [l/s] or [m<sup>3</sup>/h]
- $\Delta p_m$     Measured pressure [Pa]
- $k$          The k factor given as a function of mounting and diameter (see the table below)

Adjust the airflow rate by rotating the control spindle until the desired airflow rate (pressure difference) is achieved.

Set the tubes and spindle back into the plenum. Damper position can be locked with a knurled head screw of the adjuster.

Duct connection (PDI)	k factor for MSM adjuster, opening > 0, [l/s]	
	> 8D	Min. 3D
100	5.7	7.5
125	9.6	12.6
160	16.4	21.9
200	26.3	31.0
250	47.1	51.5
315	78.8	–

Duct connection (PDI)	k factor for MSM adjuster, opening > 0, [m <sup>3</sup> /h]	
	> 8D	Min. 3D
100	20.6	27.0
125	34.4	45.4
160	59.0	78.8
200	94.8	111.6
250	169.5	185.4
315	283.6	–

# Maintenance

Detach the front panel of the diffuser and let it balance on the hinges. If needed, each nozzle can be easily removed by pressing the stoppers and then pushing the nozzle through the front panel.

Wipe the diffuser casing, nozzles and front panel with a damp cloth.

The nozzles are replaced into the front panel by pushing. After cleaning, reattach the front panel.

## Option with balancing plenum

Remove the measurement and adjustment module by gently pulling from the shaft; not from the control spindle or measurement tubes.

Wipe the components with damp cloth instead of immersing in water. Also wipe the inner part of the plenum; detach the attenuation material, if needed.

Reassemble the module by pushing the shaft until the unit meets the stopper.

After cleaning, reattach the front panel.

# Order code

## JSC-D-A; CO-ZT

Main options	
D = Diffuser connection size [mm]	125, 160, 200, 250, 315
A = Diffuser size [mm]	420, 600
Other options and accessories	
CO = Colour	
SW	Signal white (RAL 9003)
X	Special colour (RAL xxxx)
ZT = Tailored product	
N	No
Y	Yes (ETO)

Sub product (ordered separately)	
Halton Pop PDI	Balancing plenum
CA	Ceiling adapter for different ceiling types, for size JSC-420

## Order code example

JSC-125-420; CO=SW, ZT=N