

Halton Jaz JRC – Perforated diffuser

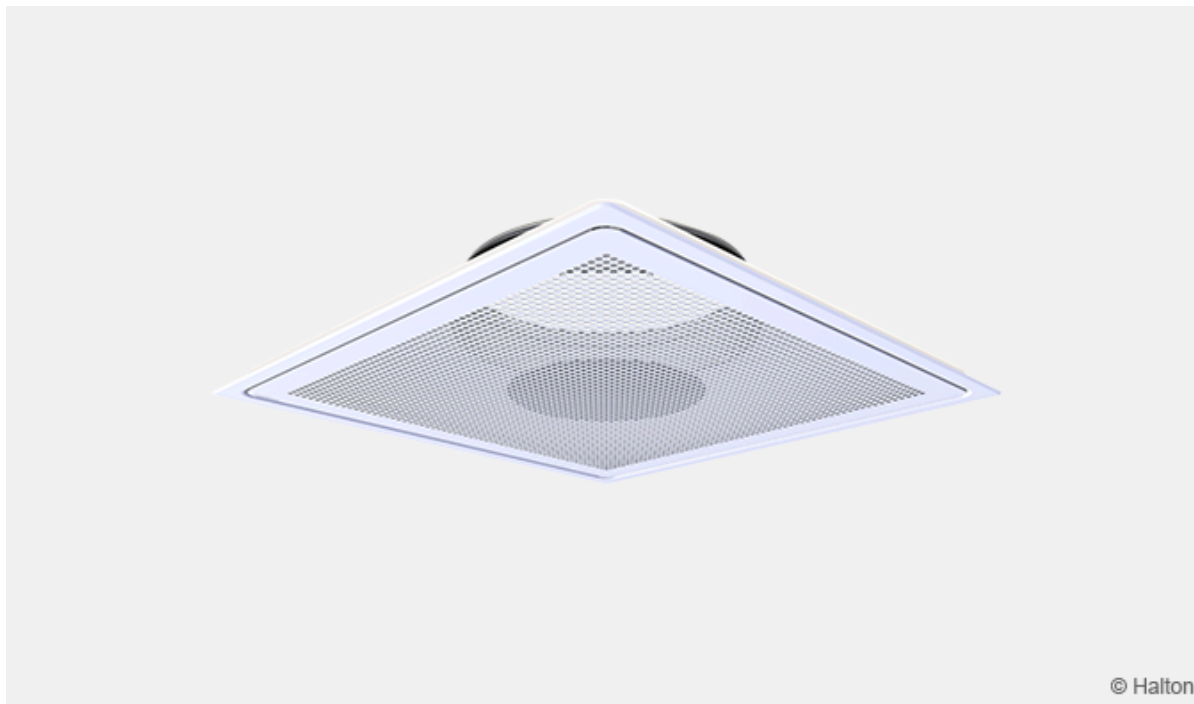

Overview

Halton Jaz JRC is a perforated diffuser with the combination of excellent indoor climate conditions and iconic design. It is available for both supply and exhaust installation, which enables a unified ceiling design.

Application area

- Ventilation in offices, hospital rooms, schools, and public spaces.

Key features

- Perforated
- Suitable for air supply and exhaust
- Silent function also with large airflows
- Adjusting and measuring with balancing plenum Halton Pop PDI
- Ceiling adapters available for different ceiling types

Operating principle

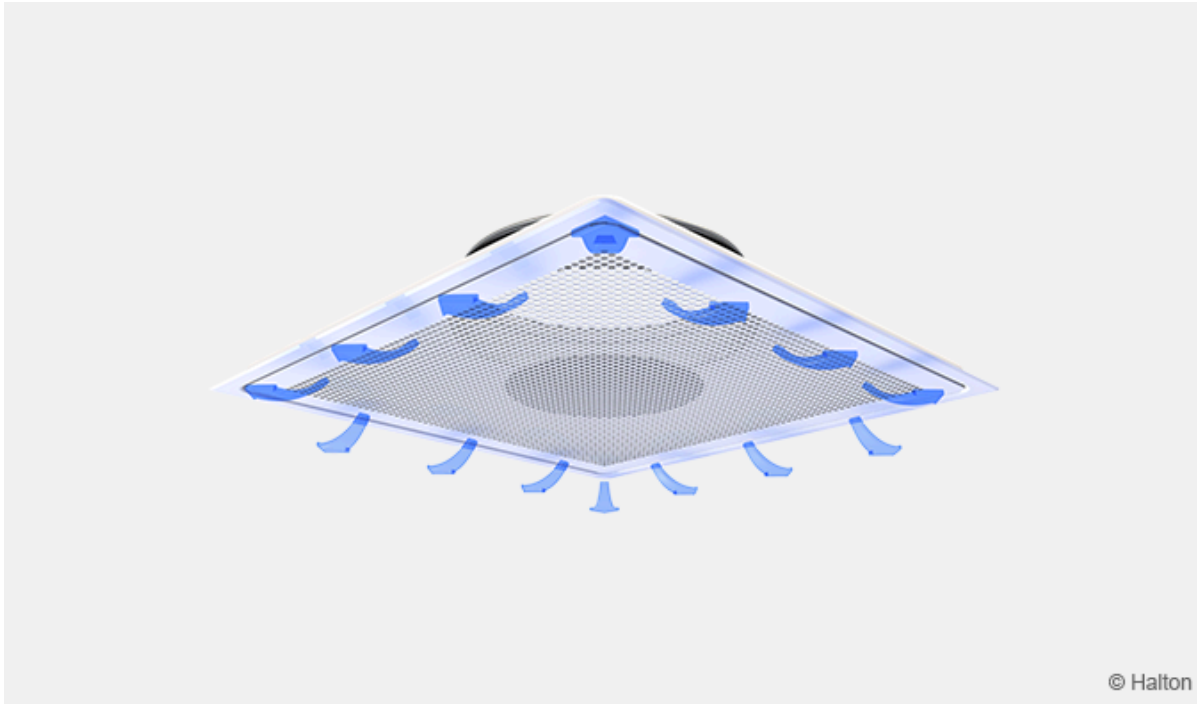

Fig.1. Operating principle of Halton Jaz JRC, supply

Air is supplied into the space through the perforated front panel of the diffuser. There is a deflector disc in the middle of the front panel, which turns the air vertically parallel to the ceiling, so that Coanda-effect would work.

The supply air pattern is 4-directional. However, the pattern can be directed to 3, 2 or 1 ways by using with separate deflector parts (DP, delivered as accessory, see section Installation).

The recommended maximum temperature difference between supply and room air as follows:

- 8 °C for 4- and 3 –way air supply direction
- 6 °C for 2- and 1–way air supply direction

Diffuser can also be used as an exhaust unit by removing the deflector disc from the middle of the front panel (*Fig. 2*).

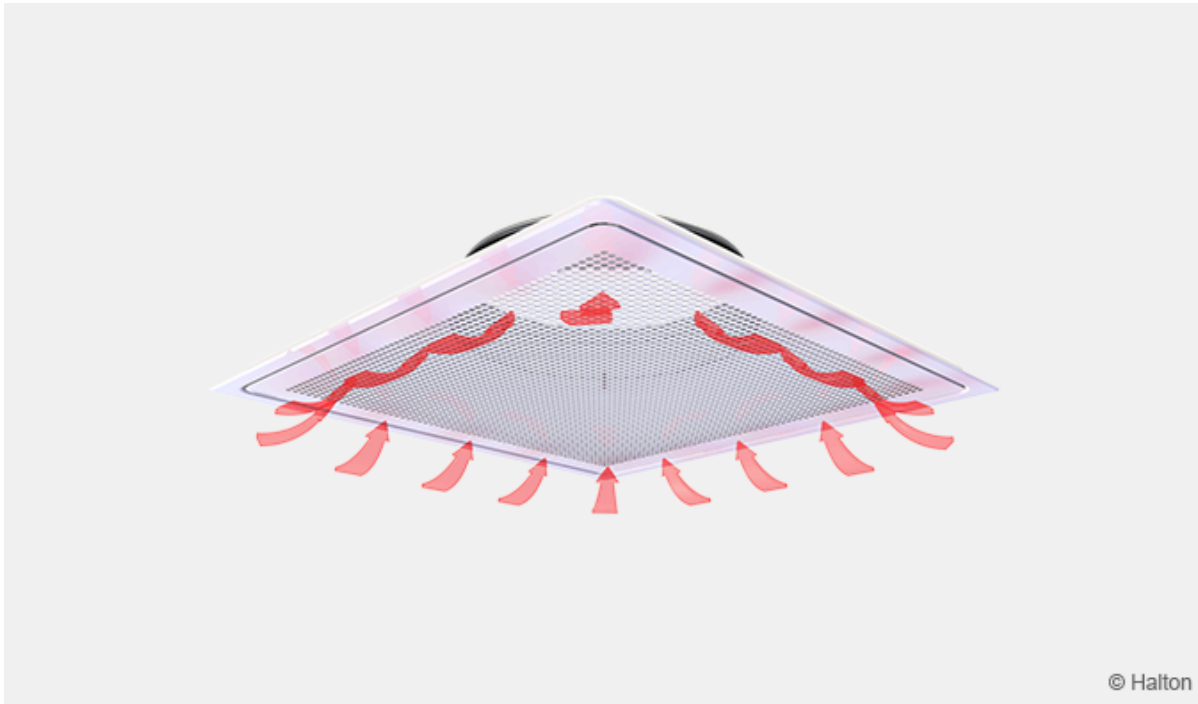

Fig.2. Operating principle of Halton Jaz JRC, exhaust

Key technical data

Feature	Description
Airflow rate	Max. airflow rate 183 l/s or 660 m ³ /h, <35 dB
Dimensions	595 x 595 mm or 420x420 mm
Weight	2.1 – 4.3 kg
Adjustability	Throw pattern adjustable with deflector parts (DP)

Features and options

Category	Feature (order code)	Option (order code)	Description
Diffuser	Duct connection size (D)	125, 160, 200, 250 or 315	Five nominal duct connections sizes. Units are in millimetres.
	Diffuser size (A)	420	420x420x50 mm. Available with duct connection sizes 125, 160 or 200.
		600	595x595x70 mm. Available with duct connection sizes 200, 250 and 315
Deflector part DP (accessory [*])	Diffuser size	420, 600	Set of panels for directing the airflow (R3, R2, or R1). Select correct diffuser size.
Balancing plenum PDI (subproduct [*])	Model (M)	S	With supply airflow adjustment and measurement module MSM
		E	With exhaust airflow adjustment module MEM
		N	Without airflow adjustment module
	Sizes	D	Plenum's duct connection size. It can be either the same or one size bigger than diffusers duct connection.
		E	Diffuser connection size. Must be the same size than diffusers duct connection size.
	Sound attenuation material (AT)	P	With polyester attenuation material
		W	With mineral wool attenuation material
		NA	Without attenuation material
	Ceiling adapter CA for 420x420 diffusers (accessory [*])	Model (M)	S1
H1			Hidden grid Ecophon Focus DS, Rockfon X
P1			Partly hidden grid Ecophon Focus Dg, Rockfon X
C1			Clip-in

		Dampa clip-in, square edge
	R1	Recessed Ecophon Focus F, Rockfon E, T24

* Ordered separately

Quick selection

Values with adjustment module (MSM) fully open.

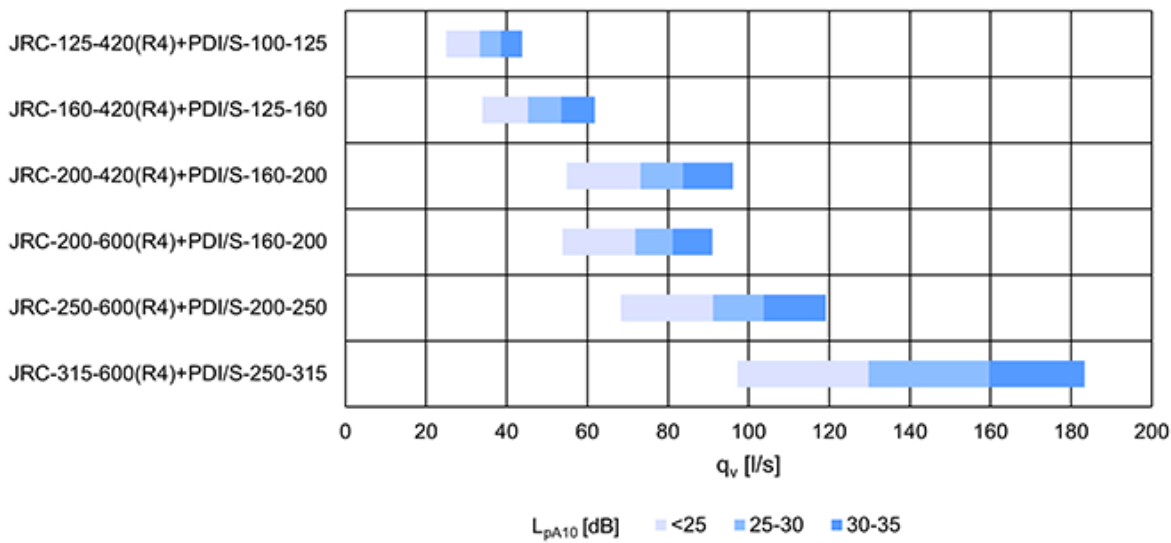

Fig. 3. Quick selection with unit l/s

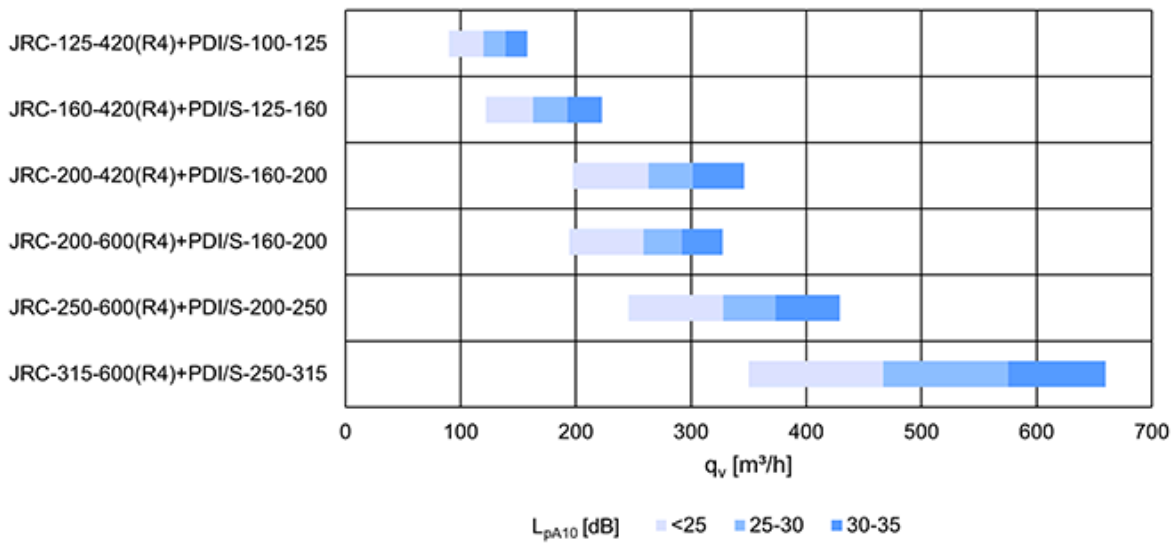
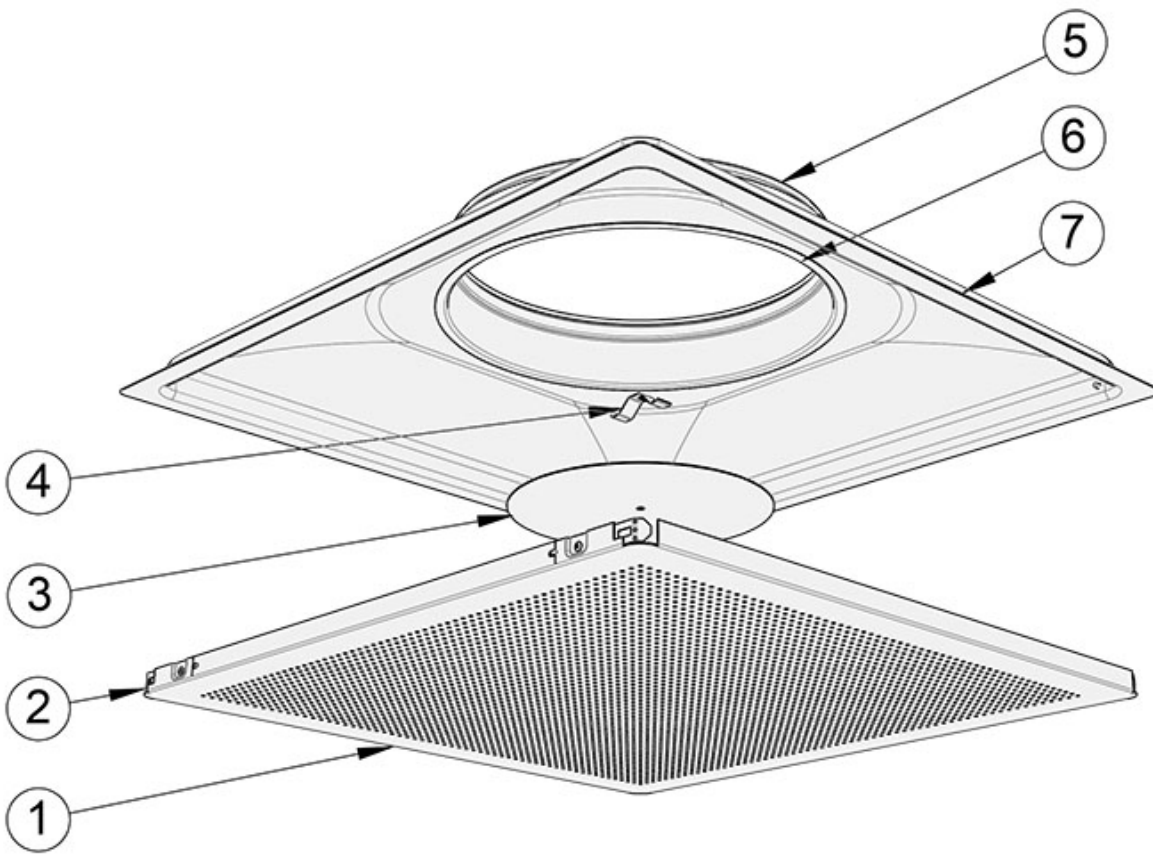

Fig. 4. Quick selection with unit m³/h

Structure and materials



No.	Part	Description	Note
1	Front panel	Polyester-painted steel, white (RAL 9003/30%)	Special colours available
2	Front panel springs	Stainless steel	–
3	Deflector disc	Pre-painted steel (black)	–
4	Spring	Stainless steel	–
5	Duct seal gasket	Polymer	–
6	Spigot	Galvanised steel	–
7	Casing	Polyester-painted steel, white (RAL 9003/30%)	Special colours available

Dimensions and weight

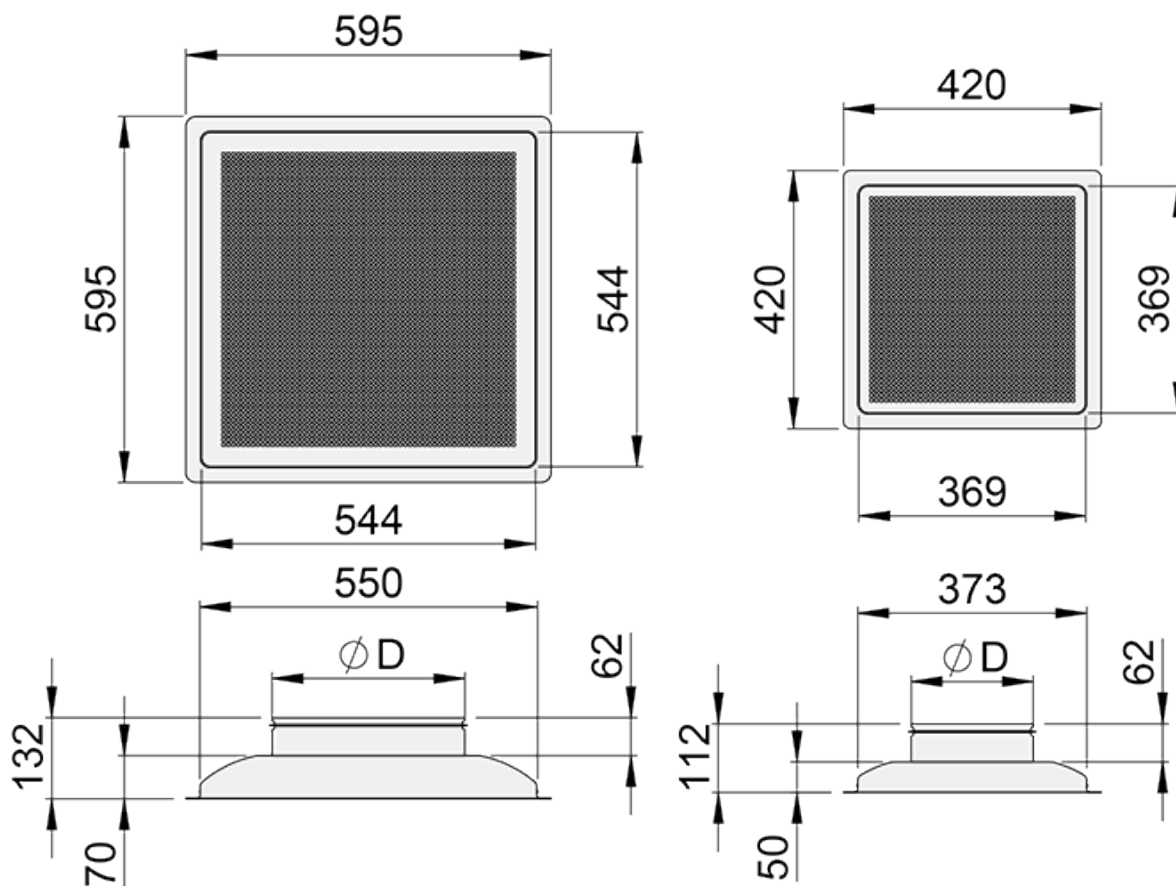

Fig. 5. Dimensions of Halton Jaz JRC diffuser, 600×600 mm (left) and 420×420 mm (right)

JRC	ØD [mm]	Weight [kg]
125-420	124	2.1
160-420	159	2.2
200-420	199	2.3
200-600	199	4.1
250-600	249	4.2
315-600	314	4.3

Halton Jaz JRC with Halton Pop PDI plenum

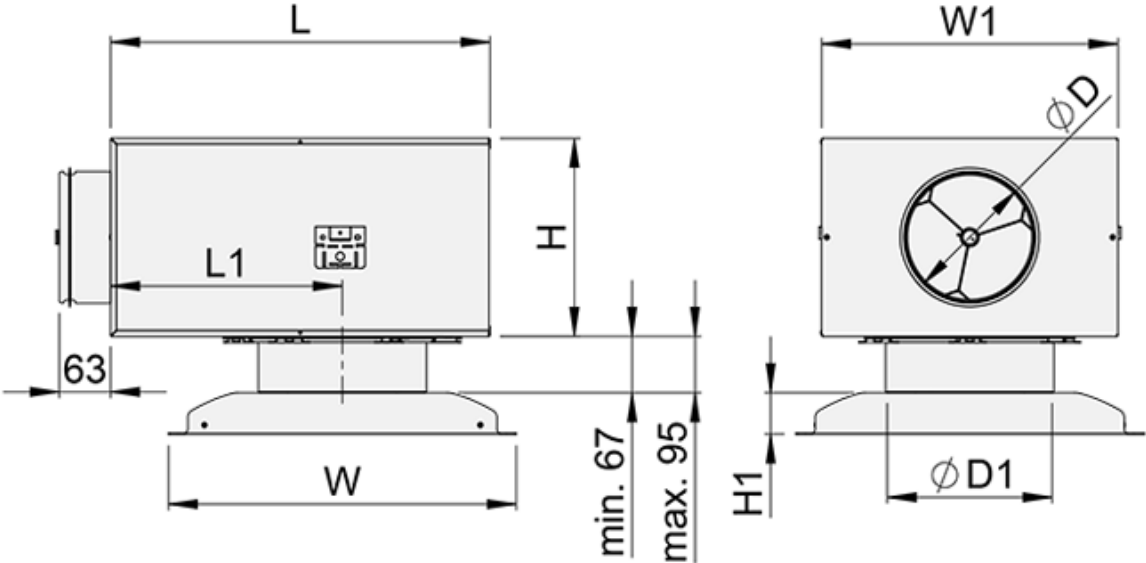

Fig. 6. Halton Jaz JRC with Halton Pop PDI plenum, externally positioned connection spigot

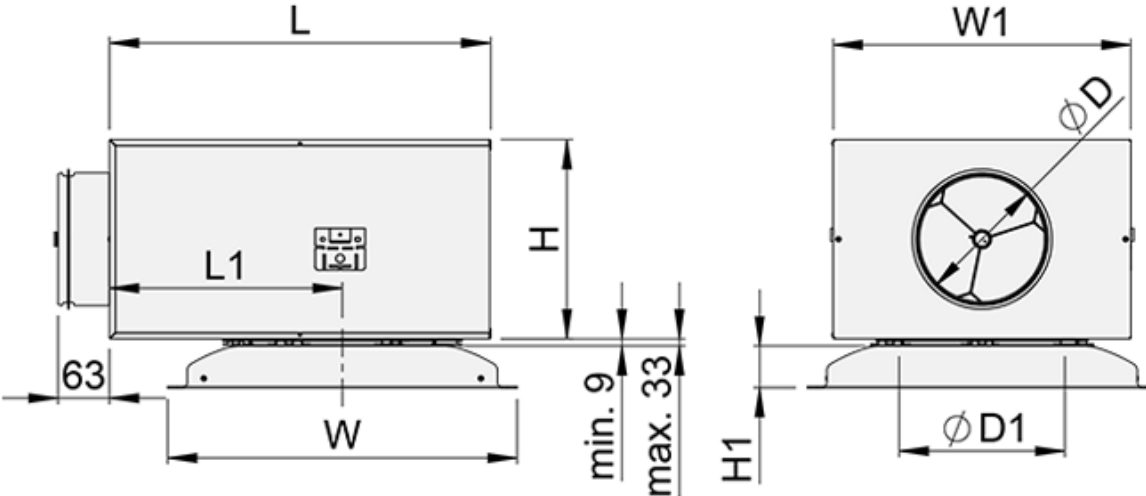

Fig. 7. Halton Jaz JRC with Halton Pop PDI plenum, internally positioned connection spigot

JRC	W [mm]	PDI	ØD [mm]	ØD1 [mm]	L [mm]	W1 [mm]	H [mm]	H1 [mm]	L1 [mm]	Weight [kg]
125-420	420	100-125	99	127	308	282	172	50	168	4.8
	420	125-125	124	127	308	282	172	50	168	4.9
160-420	420	125-160	124	162	308	282	172	50	168	4.9
	420	160-160	159	162	458	359	239	50	280	7.2
200-420	420	160-200	159	202	458	359	239	50	280	7.2
	420	200-200	199	202	458	359	239	50	280	7.3
200-600	595	160-200	159	202	458	359	239	70	280	9.0
	595	200-200	199	202	458	359	239	70	280	9.1
250-600	595	200-250	199	25	458	359	239	70	280	9.1
	595	250-250	249	252	520	480	359	70	280	12.4
315-600	595	250-315	249	317	520	480	480	70	280	12.3
	595	315-315	314	317	520	480	480	70	280	12.5

Specification

Square perforated diffuser for supply or exhaust air for false ceiling installation, fulfilling the following requirements:

Structure

- Front panel openable and removable to allow general maintenance and cleaning.
- Front panel removable without special tools.
- Four directional air distribution.
- Adjustable air throw pattern with separate deflection panel set (DP)
- Unit sizes:
 - o 595×595 mm, height 70 mm
 - o 420×420 mm, height 50 mm
- Inlet duct diameter 125, 160, 200, 250 or 315 mm.

Materials

- Casing and front panel manufactured from steel.
- Casing and front panel white, powder painted in RAL 9003, 30 % gloss.
- Connection spigot manufactured from galvanized steel.
- Connection spigot equipped with fixed gasket.

Model with balancing plenum

- Diffuser to be connected with a galvanised steel plenum Halton Pop PDI.
- Plenum has integrated gasket to ensure airtight duct connection.
- Plenum has a removable adjustment module MSM for supply or MEM for exhaust.

Packaging and identification

- The product is protected by removable plastic coating.
- The product is packed in a cardboard box.
- The product is identified by labels attached both to the product and the cardboard box.

Installation



Fig. 8. Halton Jaz JRC connected to a Halton Pop PDI plenum

The diffuser is available in size 595×595 mm for direct installation to the modular T-bar ceiling (600×600) either above or below the list.

The diffuser is usually connected to the balancing plenum Halton Pop PDI (see Fig. 6). Alternatively, it can be connected directly to the duct by riveting or screwing. In that case, minimum safety distance to the next T branch or curve is three times the duct's diameter ($3 \times \text{ØD}$).

Adaptations for different ceiling types can be made with size 420×420 mm and a separate ceiling adapter (CA, to be ordered as an accessory, see Fig. 9). See the section Download for more information about the ceiling adapters.



Fig. 9. Halton Jaz JRC, 420 with 595×595 mm ceiling adapter (CA)

Throw pattern can be adjusted by using separate deflection panel package DP. In Fig. 10., the possible directions are shown.



Fig. 10. Deflection part options

Code description

- R4 Radial jet, 4 direction
- R3 Radial jet, 3 direction
- R2 Radial jet, 2 direction
- R1 Radial jet, 1 direction
- E Exhaust

Commissioning

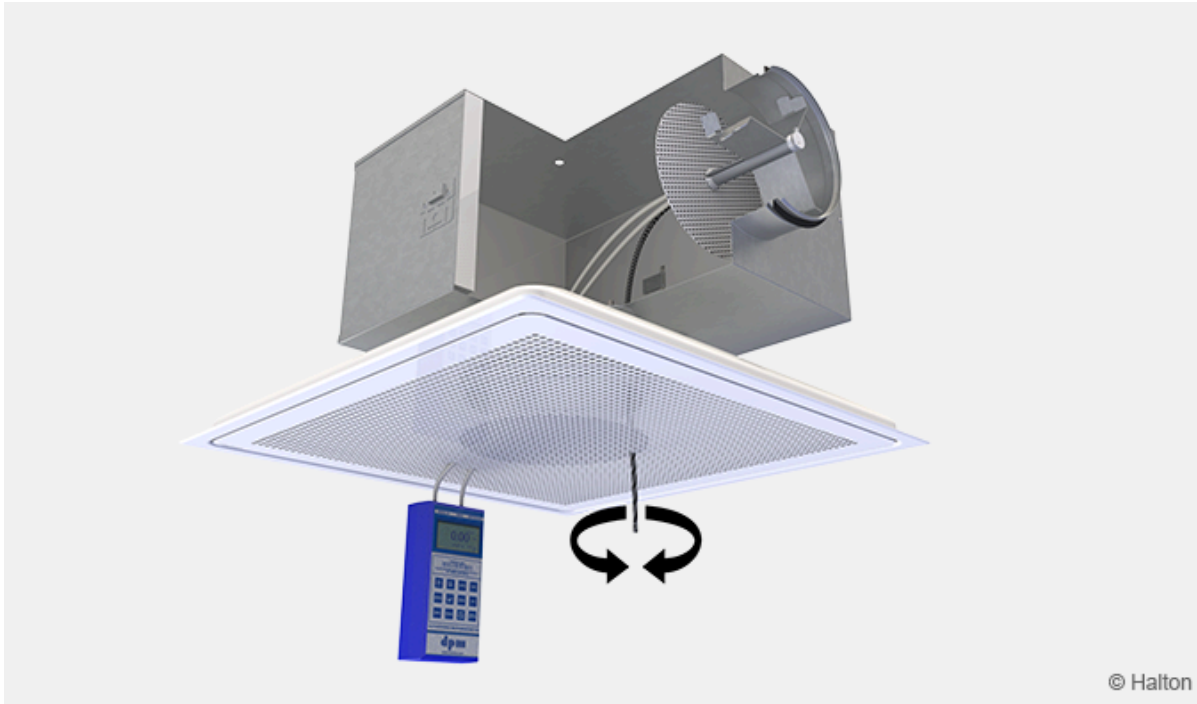

Fig. 11. Adjustment of airflow of diffuser and plenum combination

Airflow control

The diffuser itself has no airflow adjustment. To adjust and measure the supply airflow rate, the diffuser shall be combined with Halton Pop PDI balancing plenum with measurement and adjustment module MSM. In case of exhaust air, use of adjustment module MEM is recommended. It is not possible to measure exhaust airflow rate with adjustment module MEM.

Open the front plate and pass the tubes and control spindle through the front panel (*Fig. 11.*). Replace the front panel. Measure the differential pressure with a manometer. The flow rate is calculated using the formula below:

$$q_v = k\sqrt{\Delta p_m}$$

where

- q_v Airflow rate [l/s] or [m³/h]
- Ωp_m Measured pressure [Pa]
- k The k factor given as a function of mounting and diameter (see the table below)

Adjust the airflow rate by rotating the control spindle until the desired airflow rate (pressure difference) is achieved.

Set the tubes and spindle back into the plenum. Damper position can be locked with a knurled head screw of the adjuster.

Duct connection (PDI)	k factor of MSM adjuster, opening > 0 [l/s]	
	> 8D	Min. 3D
100	5.7	7.5
125	9.6	12.6
160	16.4	21.9
200	26.3	31.0
250	47.1	51.5
315	78.8	–

Duct connection (PDI)	k factor of MSM adjuster, opening > 0 [m ³ /h]	
	> 8D	Min. 3D
100	20.6	27.0
125	34.4	45.4
160	59.0	78.8
200	94.8	111.6
250	169.5	185.4
315	283.6	–

Maintenance

Detach the front panel of the diffuser and let it balance on the hinges.

Wipe the diffuser casing and front panel with damp cloth. Ensure that the deflector panels are directed as requested. After cleaning reattach the front panel.

Option with balancing plenum

Remove the measurement and adjustment module by gently pulling from the shaft; not from the control spindle or measurement tubes. Wipe the components with damp cloth instead of immersing in water. Wipe also the inner part of the plenum; detach the attenuation material if needed.

Reassemble the module by pushing the shaft until the unit meets the stopper.

After cleaning reattach the front panel.

Order code

JRC-D-A, CO-ZT

Main options	
D = Diffuser duct connection size [mm]	125, 160, 200, 250, 315
A = Diffuser size [mm]	420, 600

Other options and accessories	
C = Colour	
SW	Signal white (RAL 9003)
X	Special colour (RAL xxxx)
ZT = Tailored product	
N	No
Y	Yes (ETO)

Sub products and accessories (ordered separately)	
Halton Pop PDI	Balancing plenum
CA	Ceiling adapter for different ceiling types, for size JRC-420
DP	Set of deflection parts

Order code example

JRC-125-420, CO=SW, ZT=N