

DSH – Séparateur d’embruns hautement efficace



Overview

- High droplet and moisture separation efficiency
 - Class A results (EN 13030:2001)
 - Minimum pressure drop
- Performance tested according to EN 13030:2001 test for louvres subjected to simulated rain, at the independent laboratory
- Independent droplet removal efficiency testing carried out for single-stage, two-stage and three-stage configurations
- Tailored sizes and designs, such as modular construction, according to customer’s needs
- For wall and duct installations
- Two and three-stage units will include a coalescing and particulate filter. Normally these are an ISO Coarse 70% panel filter or ePM2,5 65% bag filter.
- The option of a mask louvre (ML) is available to architecturally disguise the vertical vane sections
- A possibility to connect with Halton Marine fire or shut-off dampers resulting in saving of the space
- Easy installation and commissioning. No special maintenance required.

Specification

Halton’s DSH high efficiency droplet separators are designed for demanding applications such as marine, oil & gas, chemical, energy industries, where reliability, easy installation and special design play an important role. Droplet separators operate on the principle of inertial vane separation and

are designed to restrict the penetration of moisture, salt spray, rainwater and airborne aerosol particles into HVAC systems, engine room intakes, machinery spaces, and diesel and gas turbine engine air intakes.

Three configurations are commonly used according to the level of droplet removal efficiency required, single stage, two stage, and three stage, but special configurations are available. Two and three stage units will include a coalescing and particulate filter. Halton is able to assist in the design and selection of the droplet separator according to the application with special consideration to the pressure drop, velocity, wind speed and direction, turbulence, and drainage.

Dimensions

DSH general drawings

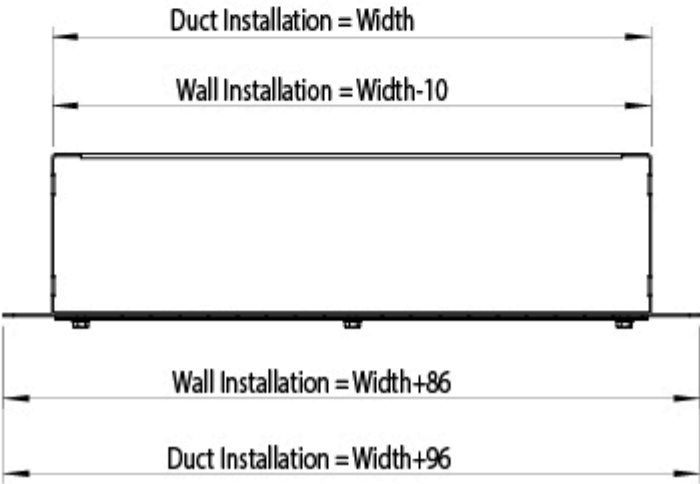
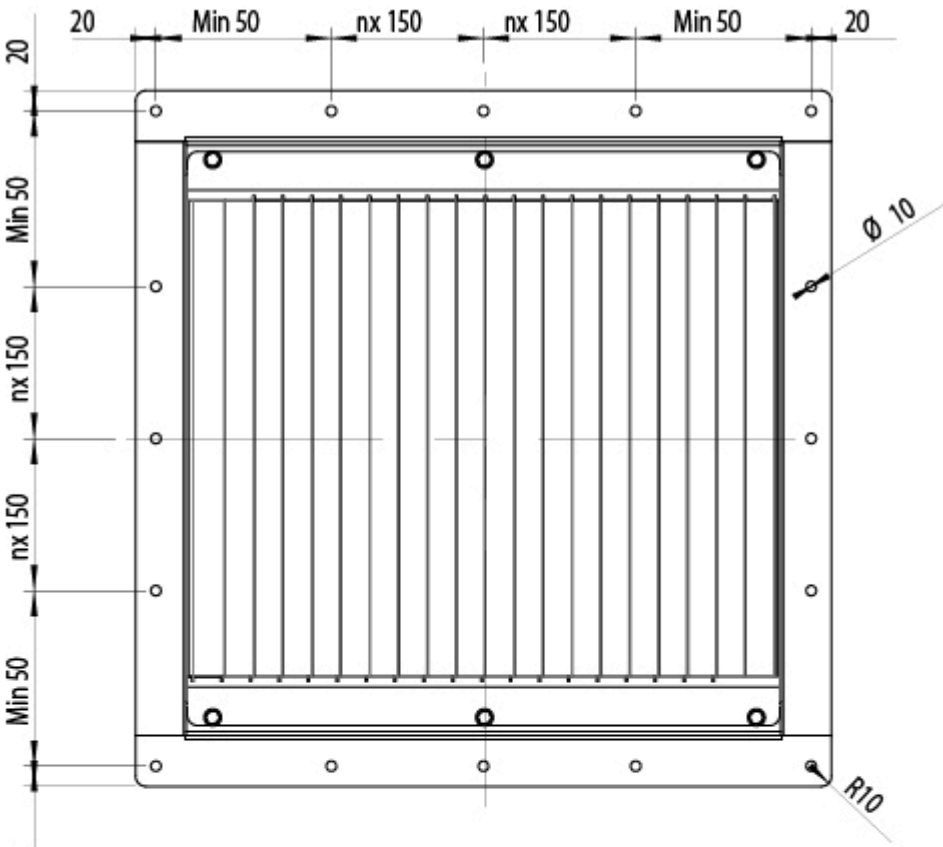

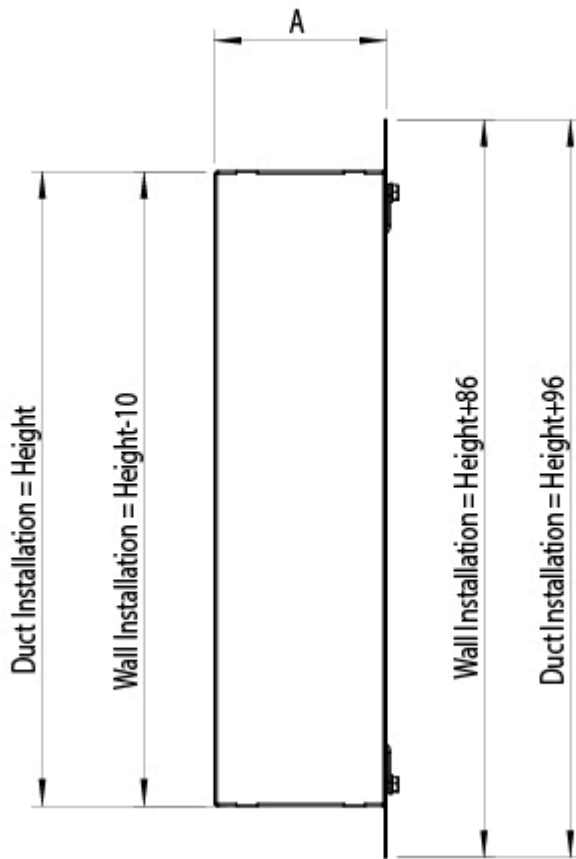

Please note that flanges in accordance with Norsok / ISO15138 are available as an option.
Special flange configurations available on request.

Dimensions table

TYPE	A WALL INSTALLATION	A DUCT INSTALLATION
DSH	160	170
DSH+ML	210	–
DSH+panel filter	225	235
DSH+panel filter+ML	275	–
DSH+bag filter	595	605
DSH+ML+bag filter	645	–

DSH = droplet separator

DSH+ML = droplet separator + mask louvre

DSH+panel filter = droplet separator + ISO Coarse 70% panel filter

DSH+panel filter+ML = droplet separator + ISO Coarse 70% panel filter with depth 360mm + mask louvre

DSH+bag filter = droplet separator + ePM2,5 65% bag filter with depth of 300 mm

DSH+ML+bag filter = droplet separator + mask louvre + ePM2,5 65% bag filter with depth of 360 mm
Net available as an option.

Material thickness

Standard frame thickness of 2 mm. 3 mm available as an option.

DSH face area dimensions

DSH single unit

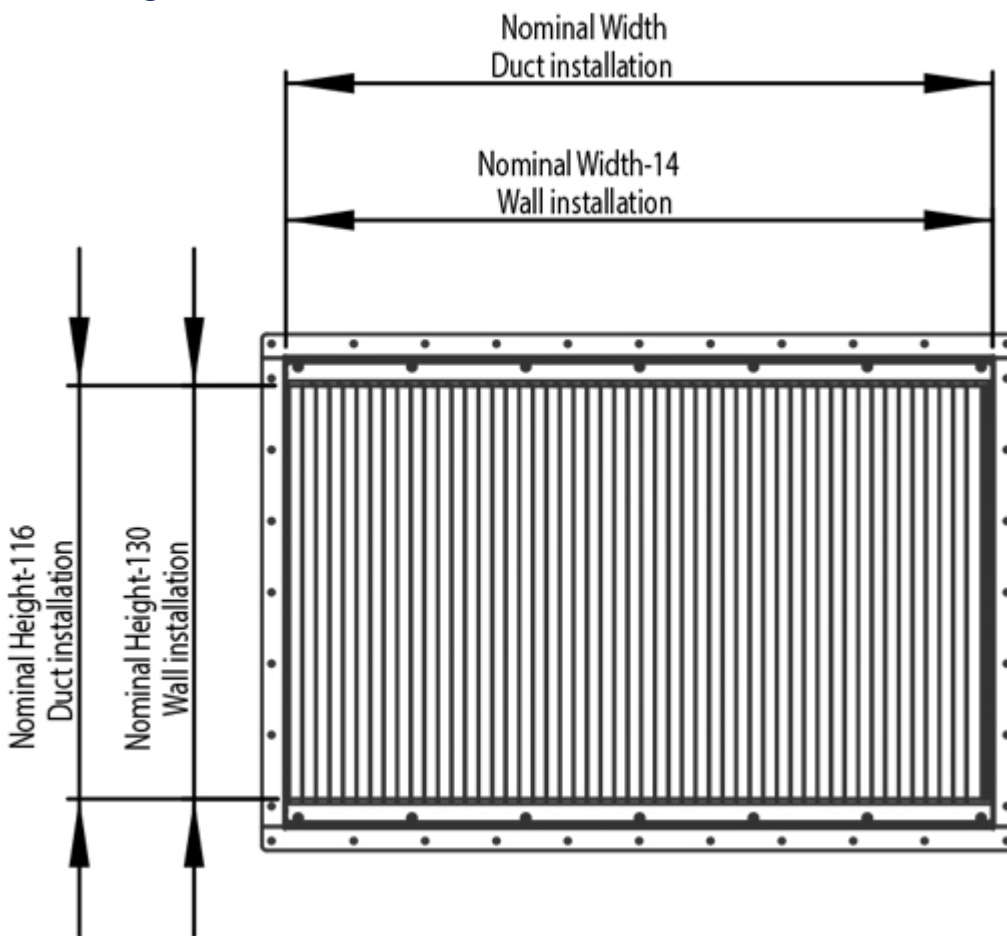

DSH module unit (width)

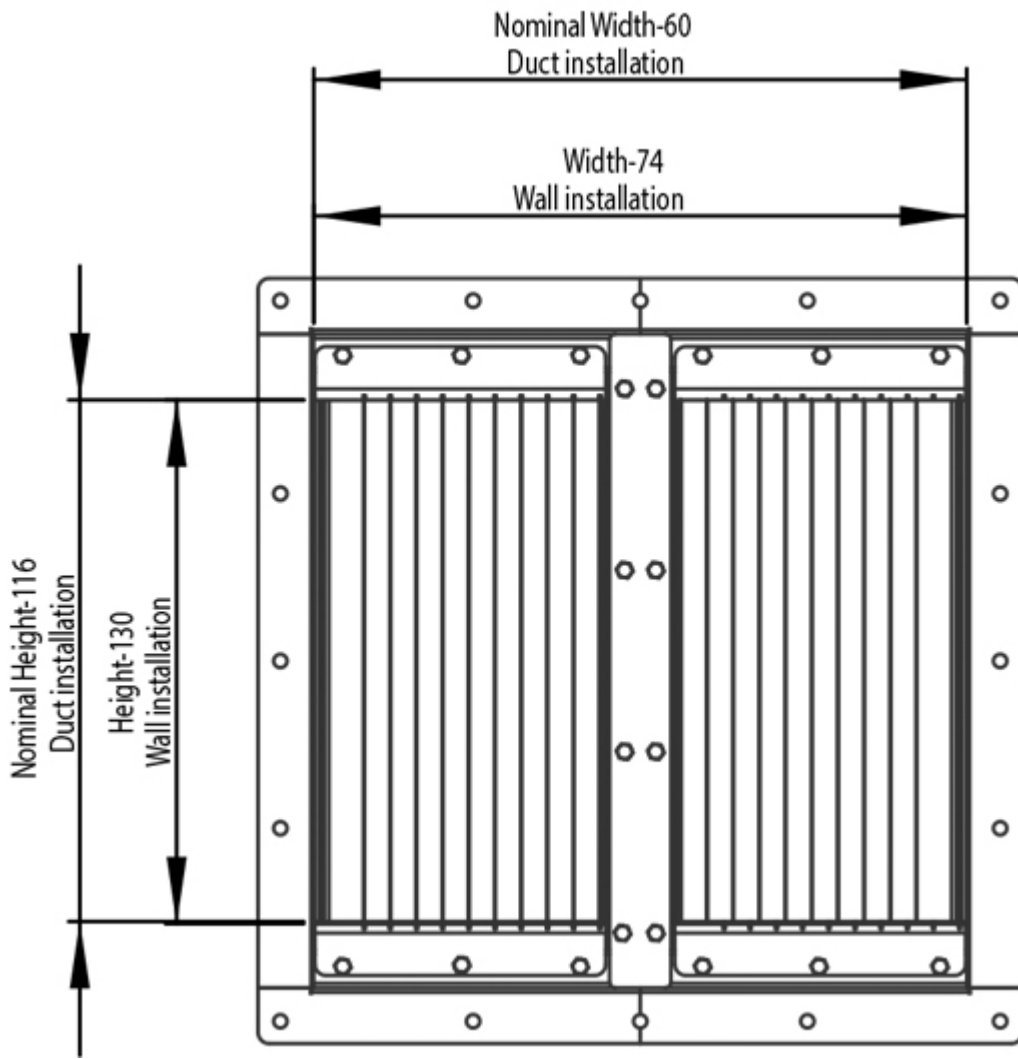

DSH module unit (height)

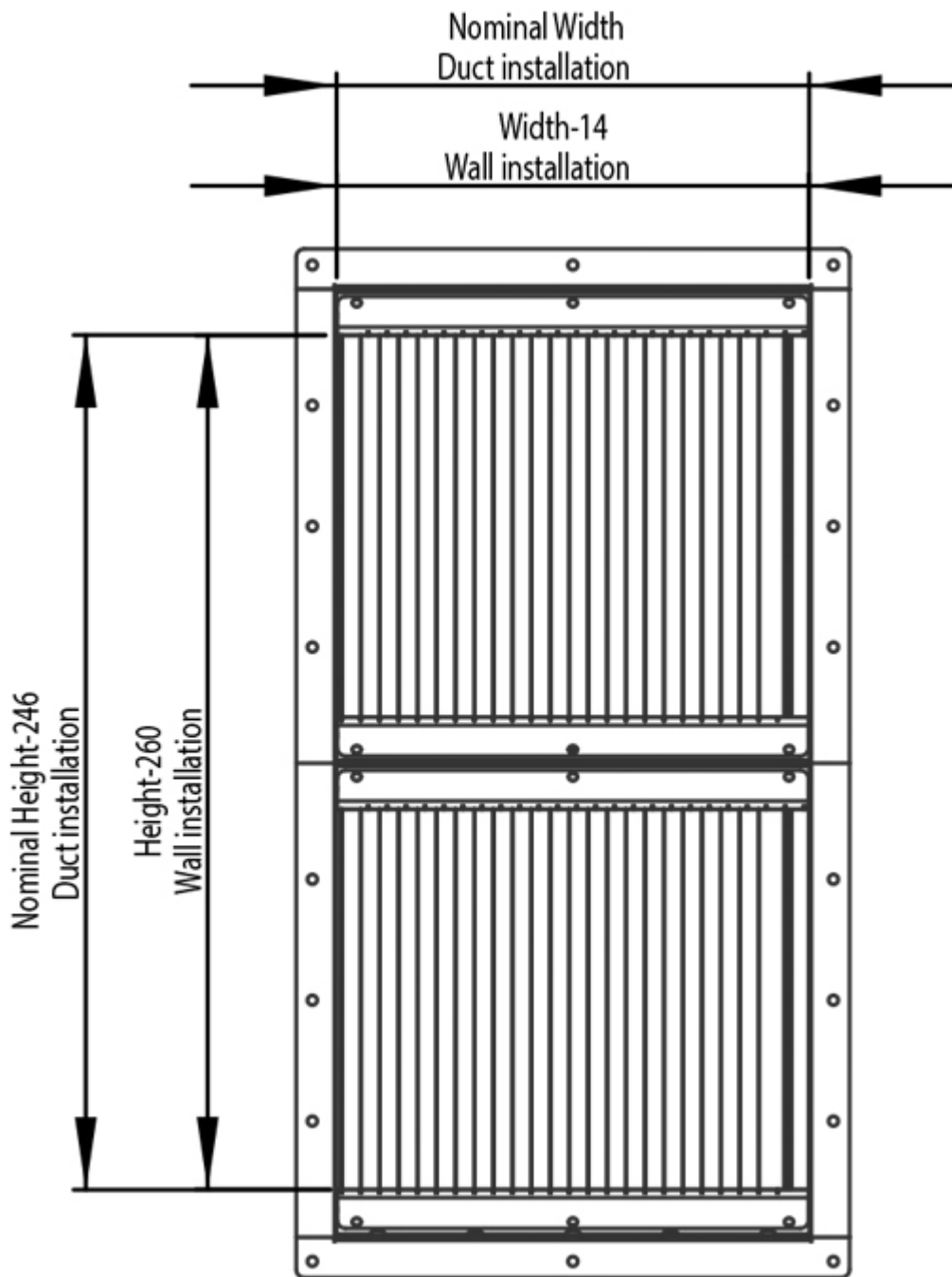

For example wall installation DSH
 Size: width 600 mm, height 600 mm
 = face area: width 586 mm, height 470 mm

General construction

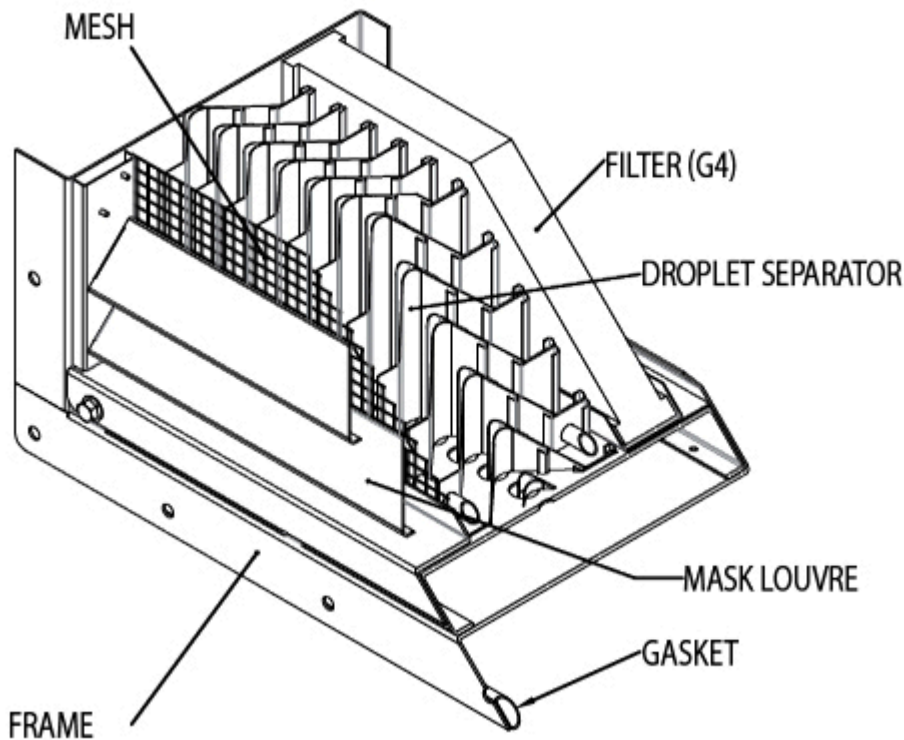

- The single-stage unit comprises DSH vane section only, vane pitch can be 28mm, 23mm or 18mm
- Two-stage units comprise DSH+panel filter or DSH+bag filter
- Three-stage units comprise DSH+panel filter+DSH or DSH+bag filter+DSH
- Special configurations are available
- Mask Louvre (ML) and mesh (ME) are available as an option
- The mesh (ME) prevents objects from entering the air intake system
- The mask louver (ML) is available to architecturally disguise the vertical vane sections
- Access to filter for removal and maintenance is LH (left hand) or RH (right hand) as standard

Material and Finishing

PART	MATERIAL	FINISHING
Droplet separator	Aluminium EN AW 6060	Painted RAL9010, C3 acc. standard* ISO 12944-2 as standard
Droplet separator	Stainless steel EN 1.4404 (AISI 316L)	Painted as an option
Mask louvre	Aluminium EN AW 5754 / AW 6060	Painted RAL9010, C3 acc. standard* ISO 12944-2 as standard
Mask louvre	Stainless steel EN 1.4404 (AISI 316L)	Painted as an option
Frame	Aluminium EN AW 5754	Painted RAL9010, C3 acc. standard* ISO 12944-2 as standard
Frame	Stainless steel EN 1.4404 (AISI 316L)	Painted as an option
Net	Stainless steel EN 1.4404 (AISI 316L)	–
Filter	ISO Coarse 70% panel filter or ePM2,5 65% bag filter, other types available on request	–

*) C3 durability of 7-15 years. C5-M with the durability of 15-25 years durability, available as an option.

Drainage

Single-stage units are supplied with front drain holes or with drainage pipes. Two and three-stage units are normally supplied with a EN 1.4404 manometric drain trap to prevent unfiltered air by-passing the droplet separator.

Drain locations

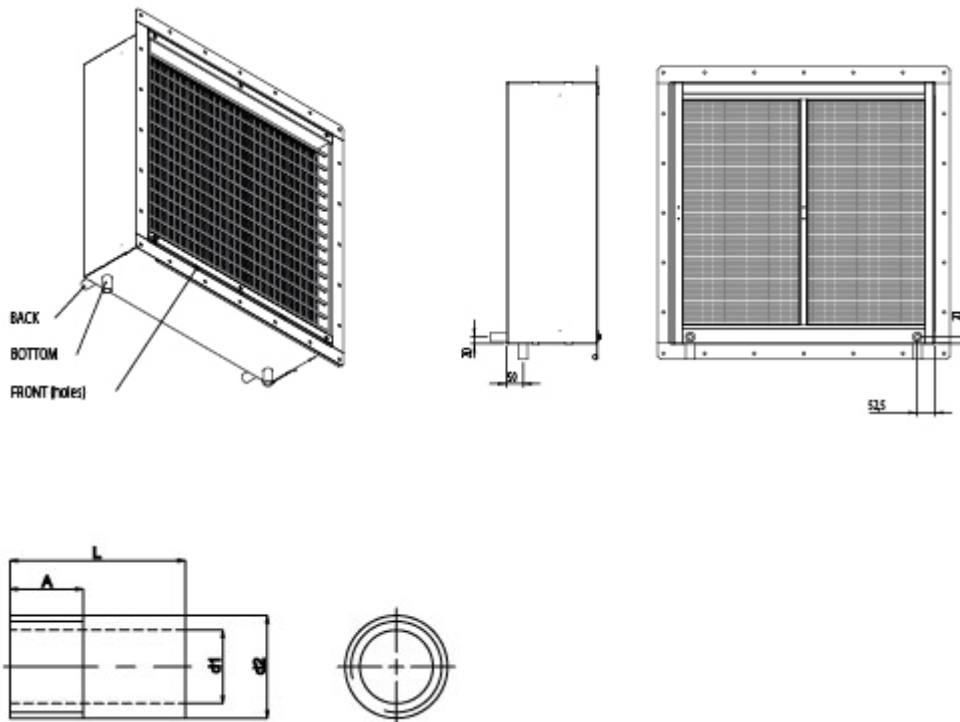

Drain pipe sizes

Weld-on nipple	Size	L	A	d1	d2
		mm	mm	mm	mm
Aluminium	1/2	50	20	15	22
	3/4	50	20	20	28
	1	60	25	25	35
Stainless steel AISI 316	1/2	35	15	16	21
	3/4	40	15	22	27
	1	40	20	26.5	34

Standard size is 3/4 ". 1/2" and 1" are available as an option. Thread type BSPT (male).

Optional features

Service hatch (SH)

Enables easy access to the filter from the side of the unit. Hatch can be placed to the left side (HL) or the right side (HR) of the DSH. (ISO Coarse 70% panel filter in the picture).

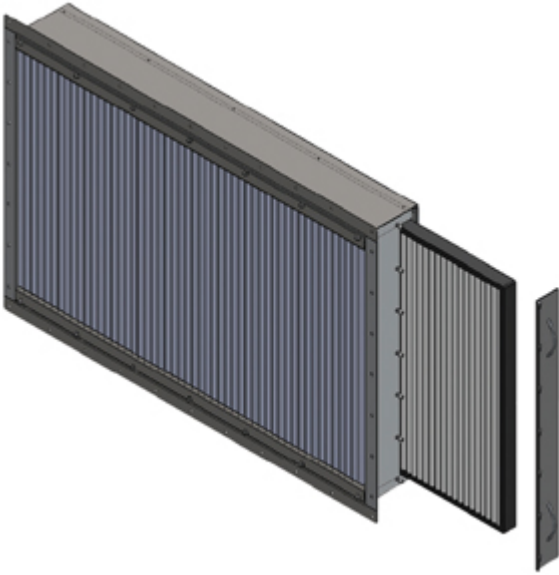

Iso Coarse 70% panel filter

Panel filters are manufactured of progressive thermally smoothed synthetic polyester having high dust holding capacity and constancy for humidity. The filters are used in general ventilation system for air purification.

ePM10 70%, ePM2,5 65% and ePM1 50% bag filters

The materials of the synthetic fine filters are high-quality and durable, progressive mounted synthetic fibres. The filters can be used in example for air purification of intake air.

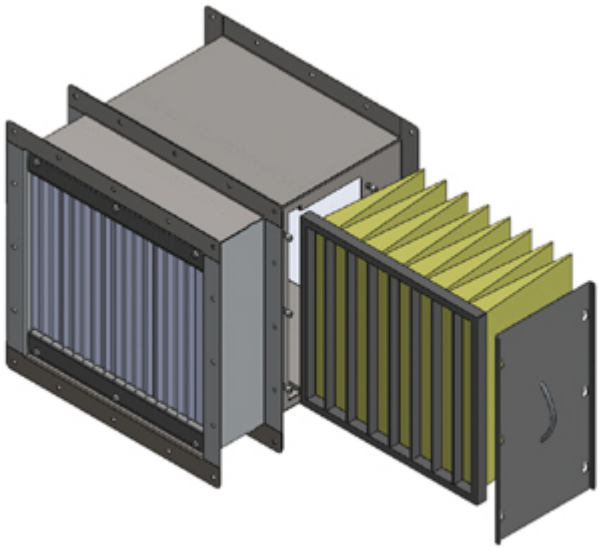

ATEX approved filters

Halton Marine also offers ATEX approved filters for droplet separators.

Installation in conjunction with a damper

Halton droplet separator can be connected to a Halton Marine fire damper with or without a connection piece. In both cases the construction is modified to fit the damper. Connecting DSH together with a damper must be mentioned when ordering products. Special flanges and drilling patterns are available for all models on request. The structural flexibility of dampers and high-quality combined with a wide range of accessories (including ex-actuators) and special steels, enable Halton Marine to offer tailored solutions for its customers. Combining Halton Marine droplet separator to damper offers customers a compact solution for air intake that also saves space. The products are recommended to be connected together at Halton Marine factory.

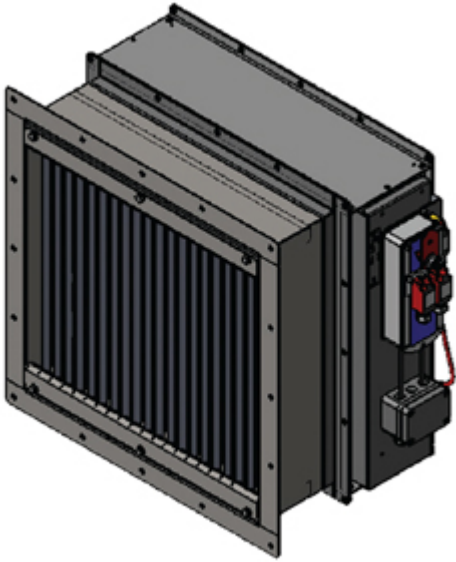

Weathertight hatch

Weathertight hatch is used e.g. to shut down the intake close to the waterline in the event of rough seas.

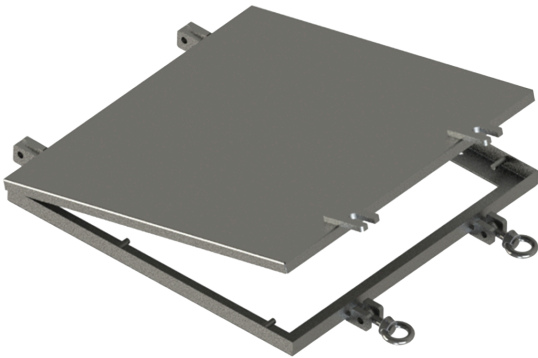

Efficiency Results

Three stage droplet separator with ISO Coarse 70% panel filter

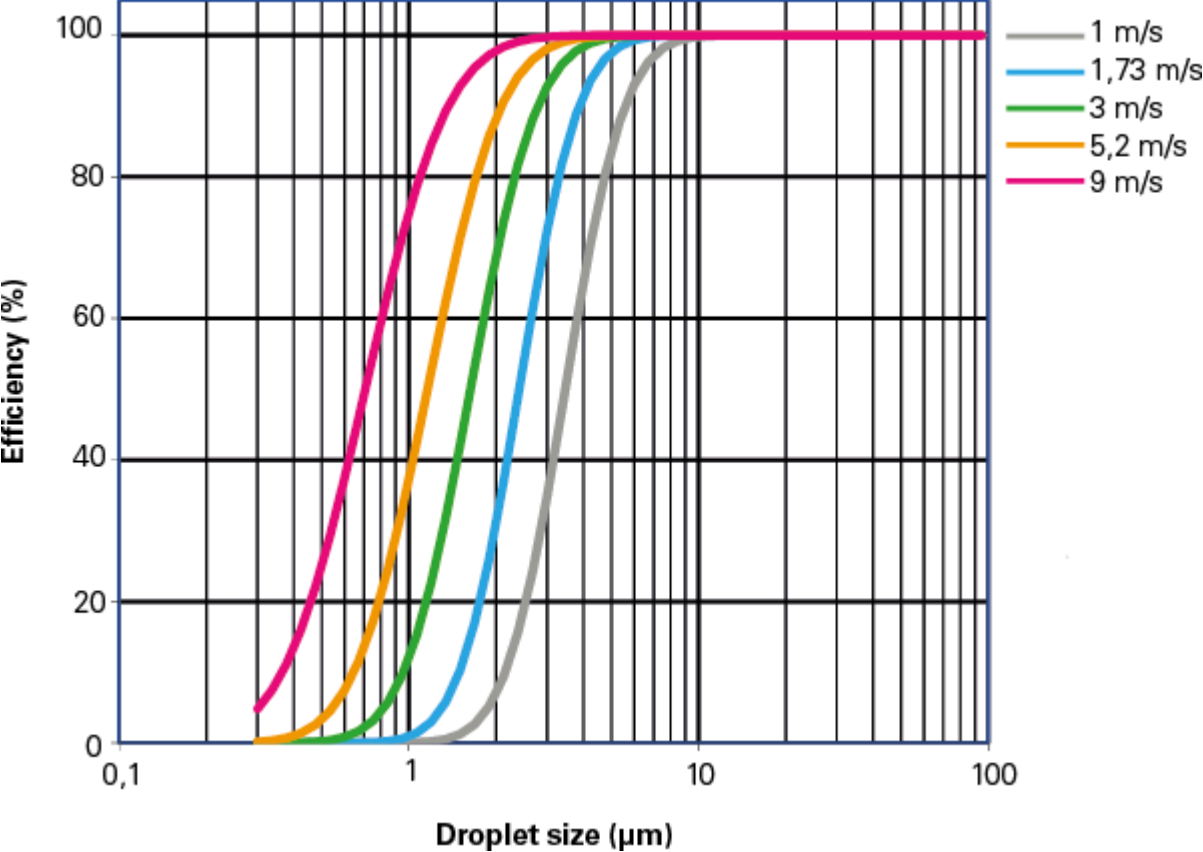

Three stage droplet separator with ePM2,5 65% bag filter

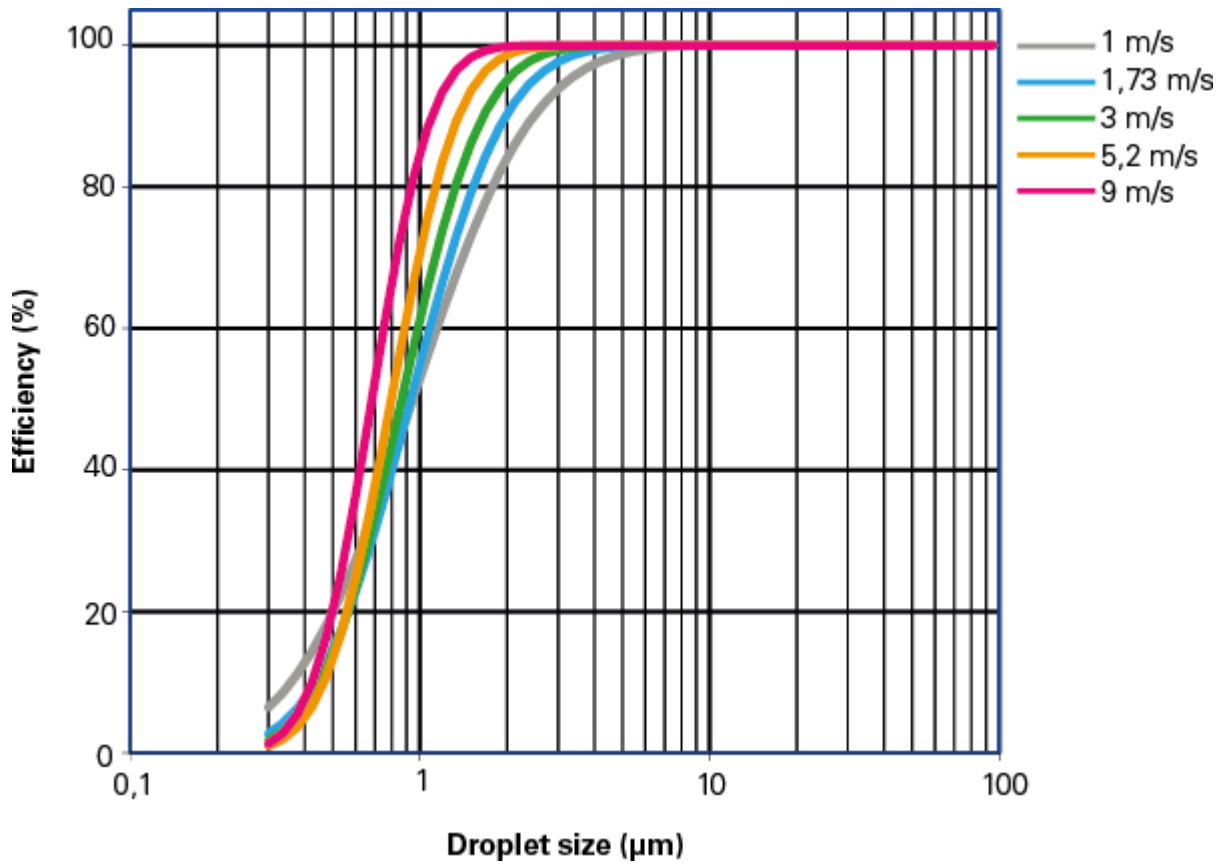

Single stage DSH, pitch spacing 18 mm

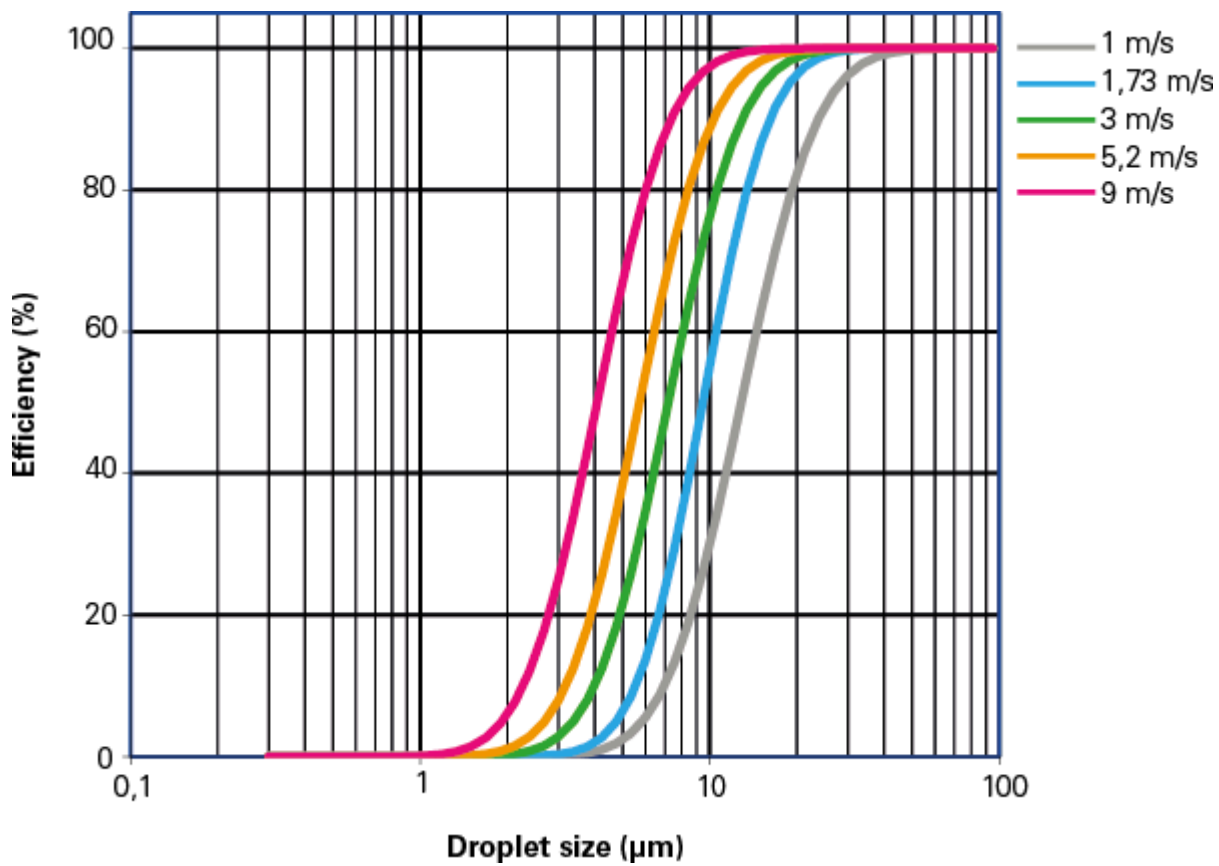

Single stage DSH, pitch spacing 23 mm

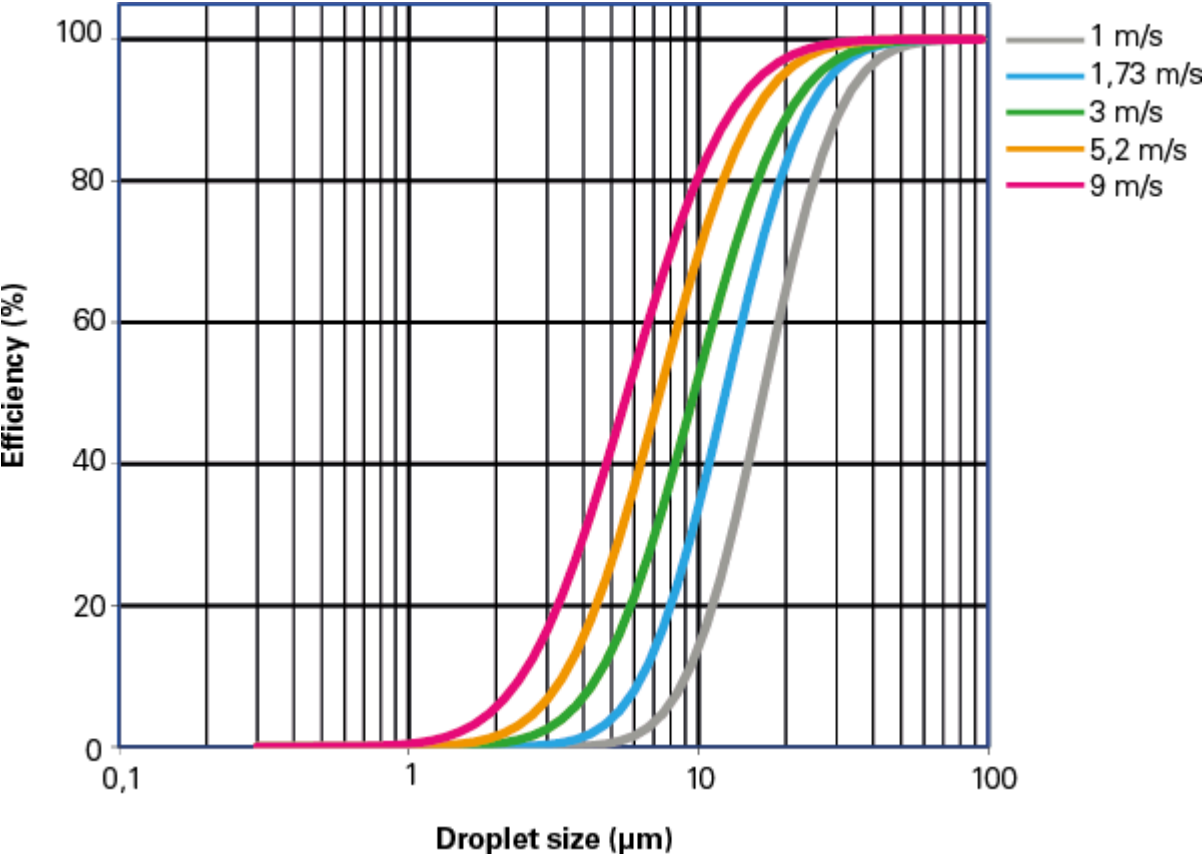

Single stage DSH, pitch spacing 28mm

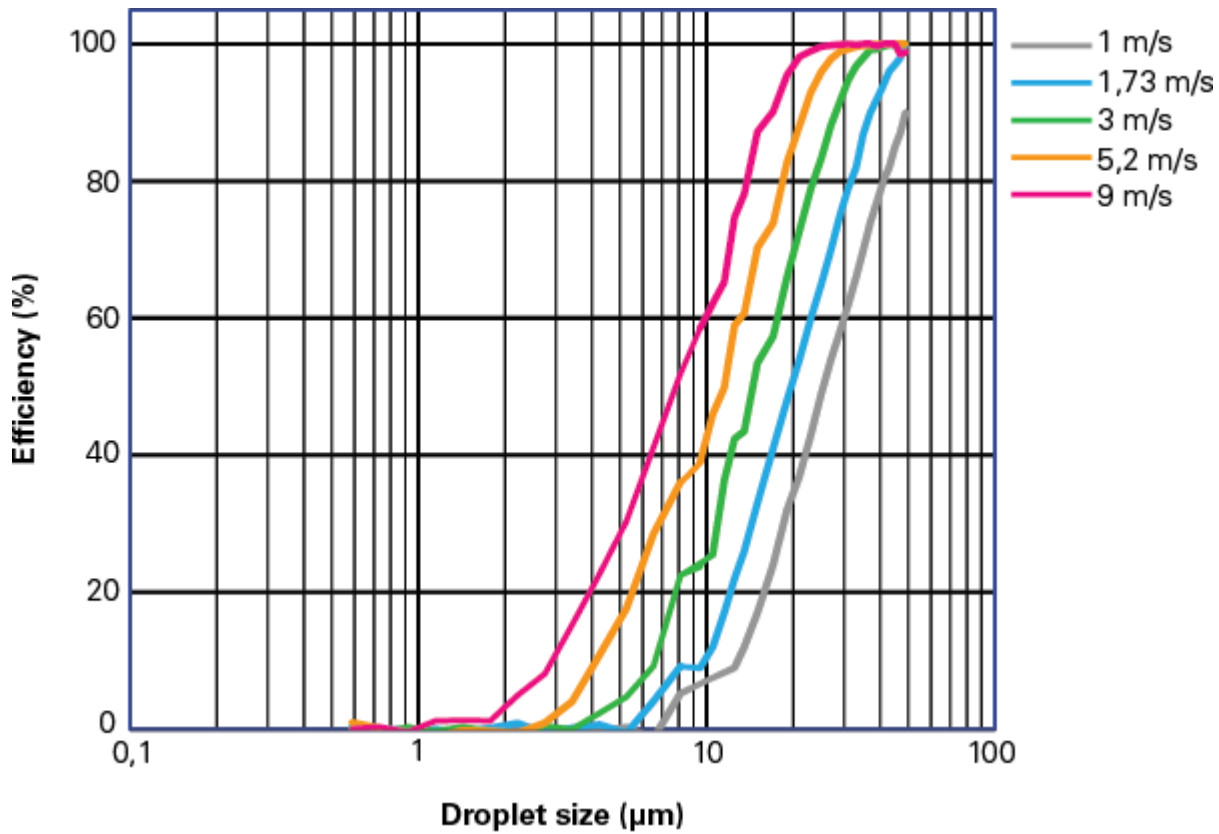

Two stage DSH with ePM2,5 65% bag filter

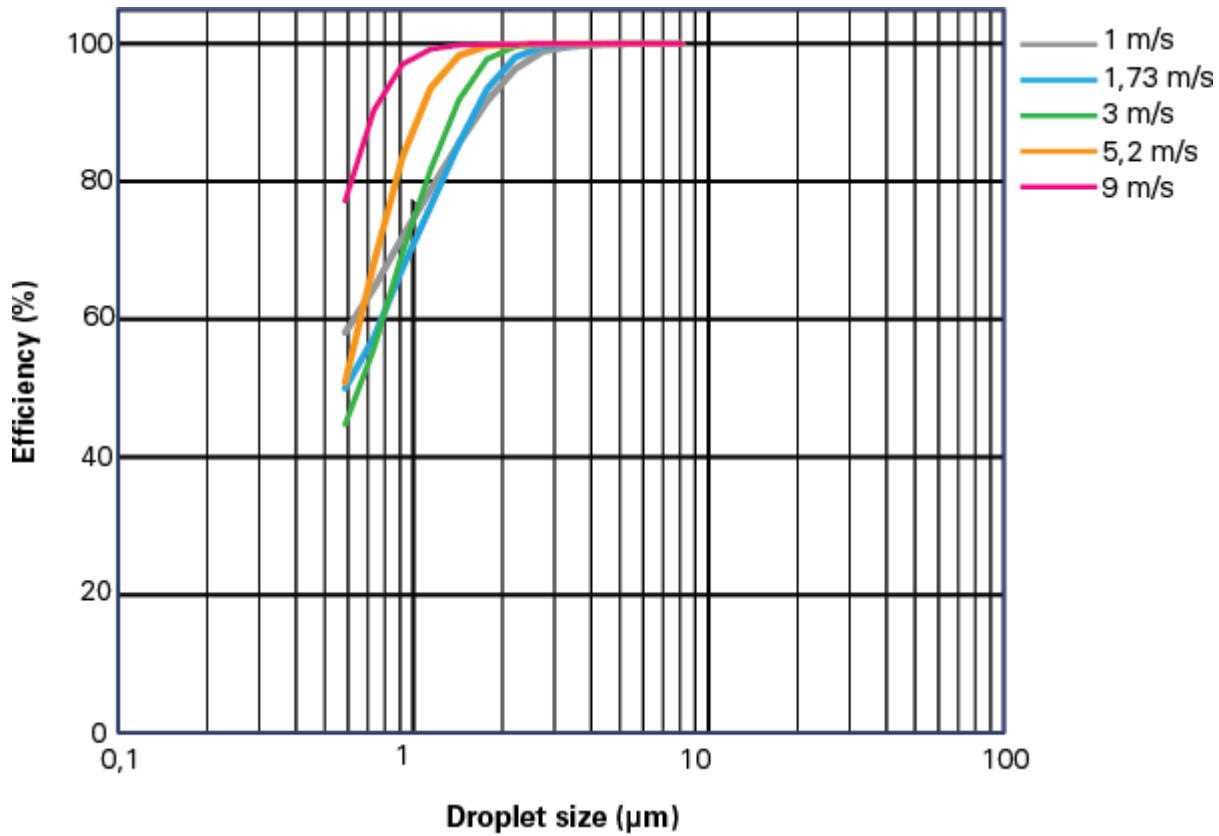

Two stage DSH with ISO Coarse 70% panel filter (filter depth 48 mm)

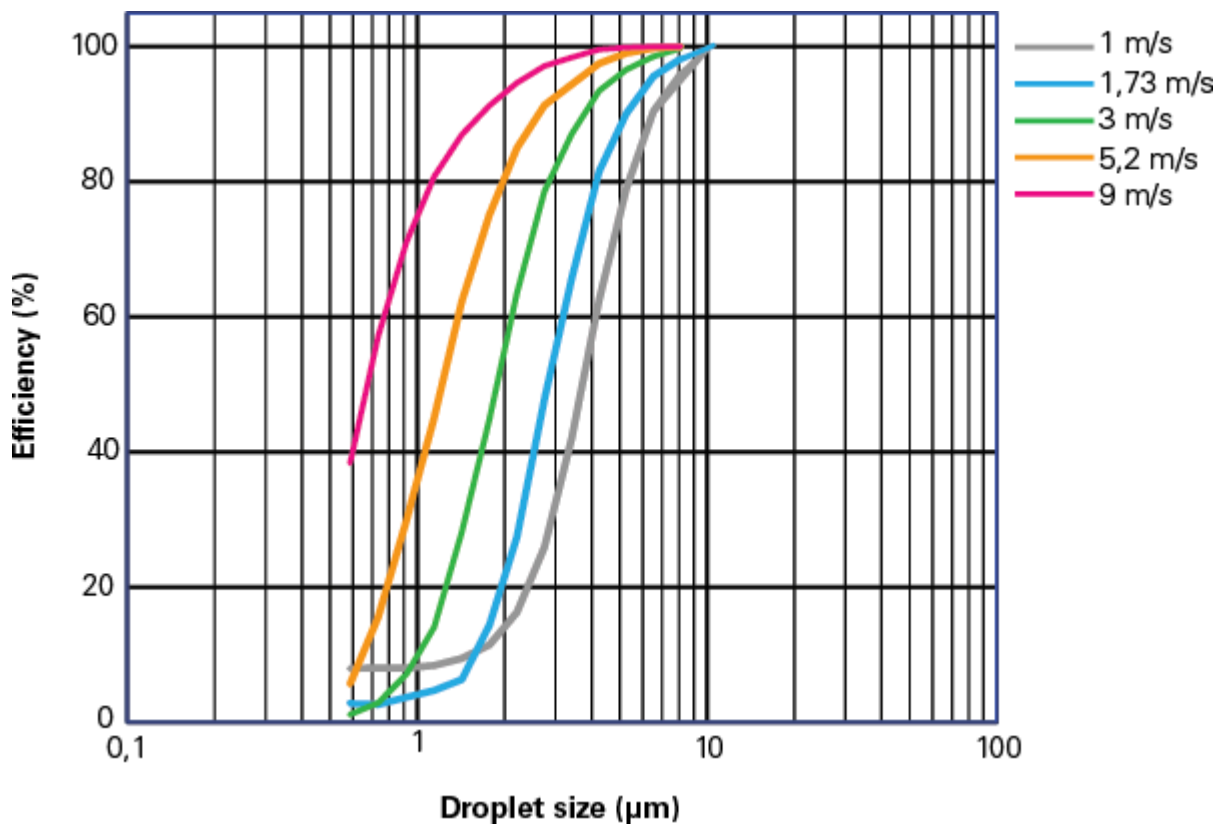

Effectiveness

Performance data

Effectiveness for removal of simulated rain
EN 13030:2001
Rainfall rate: 75 (l/h/m²), (75 mm/h)
Vertical installation

Rain water effectiveness, material aluminium

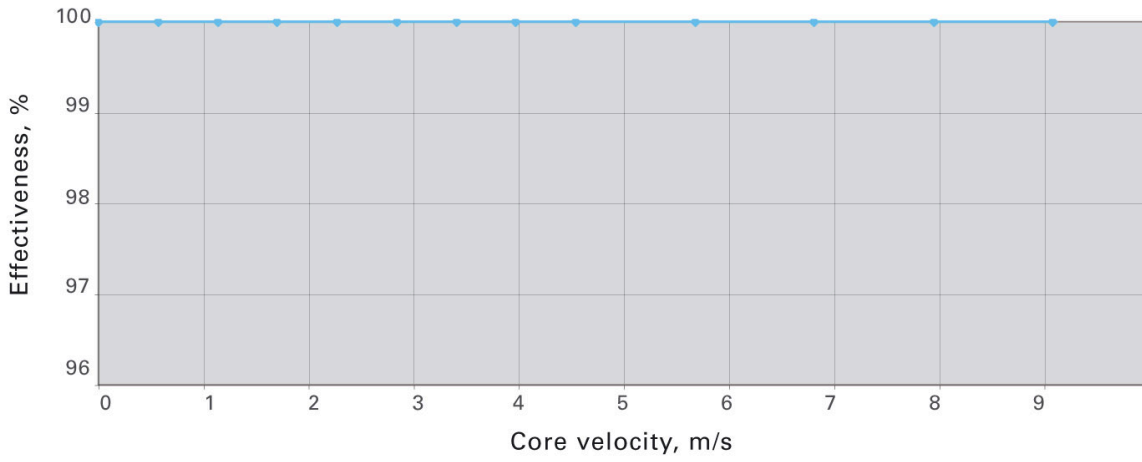

Rain water effectiveness, material stainless steel

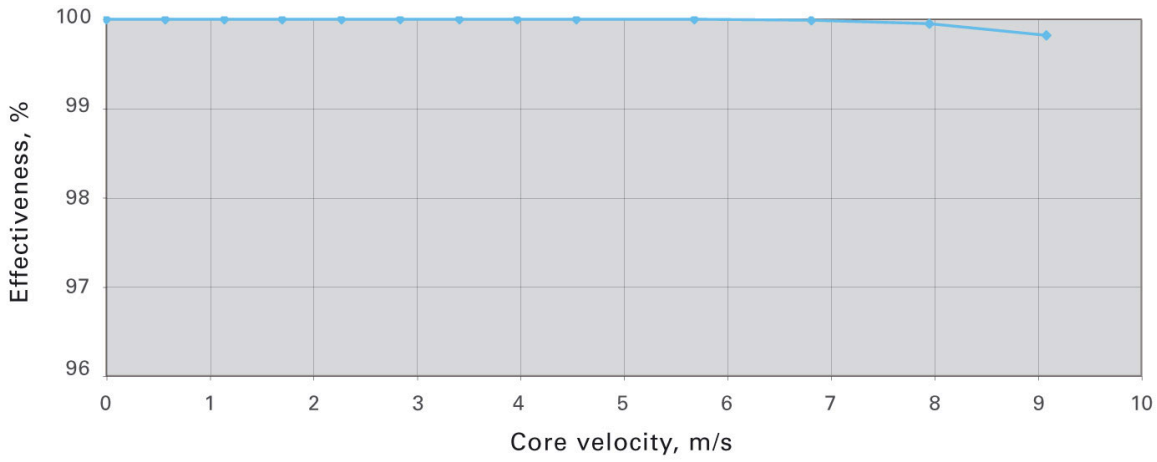

Weights

Weights of DSH including frame, aluminium (kg), pitch spacing 28 mm

H/ HEIGHT (mm)	B/WIDTH (mm)											
	200	300	400	500	600	700	800	900	1000	1100	1200	1300
200	1,7	2,1	3,1	3,9	4,8	5,8	6,7	7,6	8,6	9,4	10,3	11,2
300	2,4	2,9	4,4	5,6	6,8	8,3	9,5	10,8	12,2	13,5	14,7	15,9
400	3,1	3,7	5,7	7,3	8,9	10,8	12,4	14,0	15,9	17,5	19,1	20,7
500	3,9	4,6	7,0	8,9	10,9	13,3	15,2	17,2	19,6	21,5	23,5	25,5
600	4,6	5,4	8,3	10,6	12,9	15,8	18,1	20,4	23,3	25,6	27,9	30,2
700	5,3	6,3	9,6	12,3	14,9	18,3	20,9	23,6	27,0	29,6	32,2	34,8
800	6,0	7,1	10,9	13,9	16,9	20,8	23,8	26,8	30,6	33,6	36,6	39,6
900	6,7	7,9	12,3	15,6	19,0	23,3	26,6	30,0	34,3	37,7	41,0	44,3
1000	7,5	8,8	13,6	17,3	21,0	25,8	29,5	33,2	38,0	41,7	45,4	49,1
1100	8,2	9,6	14,9	19,0	23,0	28,3	32,4	36,4	41,7	45,7	49,8	53,8
1200	8,9	10,5	16,2	20,6	25,0	30,8	35,2	39,6	45,4	49,8	54,2	58,6

The weights on the table are indicative and do not include the filter.

Weights of DSH including frame, aluminium (kg), pitch spacing 23 mm

H/ HEIGHT (mm)	B/WIDTH (mm)										
	200	300	400	500	600	700	800	900	1000	1100	1200
200	2,3	3,3	4,5	5,5	6,5	7,5	8,6	9,6	10,6	11,6	12,8
300	3,4	4,9	6,6	8,1	9,6	11,1	12,8	14,3	15,7	17,2	18,9
400	4,5	6,4	8,8	10,7	12,7	14,6	16,9	18,9	20,8	22,8	25,1
500	5,6	8,0	10,9	13,3	15,8	18,2	21,1	23,5	25,9	28,4	31,3
600	6,6	9,5	13,0	15,9	18,8	21,7	25,2	28,1	31,0	33,9	37,5
700	7,7	11,1	15,2	18,6	21,9	25,3	29,4	32,8	36,1	39,5	43,6
800	8,8	12,6	17,3	21,2	25,0	28,9	33,6	37,4	41,2	45,1	49,8
900	9,9	14,2	19,5	23,8	28,1	32,4	37,7	42,0	46,4	50,7	56,0
1000	10,9	15,7	21,6	26,4	31,2	36,0	41,9	46,7	51,5	56,2	62,1
1100	12,0	17,3	23,8	29,0	34,3	39,6	46,0	51,3	56,6	61,8	68,3
1200	13,1	18,8	25,9	31,6	37,4	43,1	50,2	55,9	61,7	67,4	74,5

The weights on the table are indicative and do not include the filter.

Weights of DSH including frame, aluminium (kg), pitch spacing 18 mm

H/ HEIGHT (mm)	B/WIDTH (mm)											
	200	300	400	500	600	700	800	900	1000	1100	1200	1300
200	2,6	3,7	4,9	6,0	7,2	8,3	9,4	10,6	11,7	12,9	14,0	15,1
300	3,9	5,7	7,4	9,1	10,8	12,6	14,3	16,0	17,8	19,5	21,2	22,9
400	5,2	7,6	9,9	12,2	14,5	16,8	19,2	21,5	23,8	26,1	28,5	30,8
500	6,5	9,5	12,4	15,3	18,2	21,1	24,0	27,0	29,9	32,8	35,7	38,6
600	7,9	11,4	14,9	18,4	21,9	25,4	28,9	32,4	35,9	39,4	42,9	46,4
700	9,2	13,3	17,4	21,5	25,6	29,7	33,8	37,9	42,0	46,1	50,2	54,3
800	10,5	15,2	19,9	24,6	29,2	33,9	38,6	43,3	48,0	52,7	57,4	62,1
900	11,8	17,1	22,4	27,6	32,9	38,2	43,5	48,8	54,1	59,3	64,6	69,9
1000	13,1	19,0	24,9	30,7	36,6	42,5	48,4	54,2	60,1	66,0	71,9	77,8
1100	14,4	20,9	27,4	33,8	40,3	46,8	53,2	59,7	66,2	72,6	79,1	85,6
1200	15,7	22,8	29,9	36,9	44,0	51,0	58,1	65,1	72,2	79,3	86,3	93,4

The weights on the table are indicative and do not include the filter.

Weights of DSH+ML including frame, aluminium (kg), pitch spacing 28 mm

H/ HEIGHT (mm)	B/WIDTH (mm)										
	200	300	400	500	600	700	800	900	1000	1100	1200
200	2,8	4,1	5,2	6,3	7,6	8,7	9,9	11,1	12,2	13,4	14,6
300	3,8	5,6	7,2	8,8	10,6	12,1	13,7	15,5	17,1	18,6	20,4
400	4,8	7,2	9,2	11,2	13,5	15,5	17,5	19,9	21,9	23,9	26,2
500	5,9	8,8	11,2	13,6	16,5	19,0	21,4	24,3	26,7	29,1	32,1
600	6,9	10,3	13,2	16,0	19,5	22,4	25,2	28,7	31,5	34,4	37,9
700	7,9	11,9	15,2	18,5	22,5	25,8	29,1	33,1	36,4	39,6	43,7
800	8,9	13,5	17,2	20,9	25,5	29,2	32,9	37,5	41,2	44,9	49,5
900	9,9	15,0	19,2	23,3	28,4	32,6	36,7	41,9	46,0	50,2	55,3
1000	10,9	16,6	21,2	25,8	31,4	36,0	40,6	46,2	50,8	55,4	61,1
1100	12,0	18,2	23,2	28,2	34,4	39,4	44,4	50,6	55,6	60,7	66,9
1200	13,0	19,7	25,2	30,6	37,4	42,8	48,3	55,0	60,5	65,9	72,7

The weights on the table are indicative and do not include the filter.

Weights of DSH+ML including frame, aluminium (kg), pitch spacing 23 mm

H/ HEIGHT (mm)	B/WIDTH (mm)											
	200	300	400	500	600	700	800	900	1000	1100	1200	1300
200	3,1	4,3	5,7	7,0	8,3	9,5	10,9	12,2	13,5	14,7	16,1	17,4
300	4,3	6,1	8,2	10,0	11,8	13,7	15,7	17,5	19,4	21,2	23,2	25,1
400	5,6	7,9	10,7	13,0	15,4	17,8	20,5	22,9	25,2	27,6	30,3	32,9
500	6,8	9,7	13,2	16,1	19,0	21,9	25,3	28,2	31,1	34,0	37,4	40,8
600	8,1	11,6	15,6	19,1	22,6	26,0	30,1	33,6	37,0	40,5	44,5	48,4
700	9,3	13,4	18,1	22,1	26,1	30,1	34,9	38,9	42,9	46,9	51,7	56,4
800	10,6	15,2	20,6	25,1	29,7	34,3	39,7	44,2	48,8	53,4	58,8	64,1
900	11,9	17,0	23,0	28,2	33,3	38,4	44,5	49,6	54,7	59,8	65,9	71,9
1000	13,1	18,8	25,5	31,2	36,8	42,5	49,2	54,9	60,6	66,2	73,0	79,7
1100	14,4	20,6	28,0	34,2	40,4	46,6	54,0	60,2	66,5	72,7	80,1	87,4
1200	15,6	22,4	30,5	37,2	44,0	50,7	58,8	65,6	72,3	79,1	87,2	95,2

The weights on the table are indicative and do not include the filter.

Weights of DSH+ML including frame, aluminium (kg), pitch spacing 18 mm

H/ HEIGHT (mm)	B/WIDTH (mm)											
	200	300	400	500	600	700	800	900	1000	1100	1200	1300
200	3,3	4,7	6,1	7,5	8,9	10,3	11,7	13,1	14,5	15,9	17,3	18,7
300	4,8	6,9	9,0	11,0	13,1	15,2	17,2	19,3	21,4	23,4	25,5	27,5
400	6,3	9,1	11,8	14,5	17,3	20,0	22,7	25,5	28,2	30,9	33,7	36,4
500	7,8	11,2	14,6	18,0	21,4	24,8	28,2	31,6	35,0	38,5	41,9	45,3
600	9,3	13,4	17,5	21,5	25,6	29,7	33,7	37,8	41,9	46,0	50,0	54,0
700	10,8	15,5	20,3	25,0	29,8	34,5	39,2	44,0	48,7	53,5	58,2	62,9
800	12,3	17,7	23,1	28,5	33,9	39,3	44,7	50,1	55,6	61,0	66,4	71,8
900	13,8	19,9	25,9	32,0	38,1	44,2	50,2	56,3	62,4	68,5	74,5	80,6
1000	15,3	22,0	28,8	35,5	42,3	49,0	55,7	62,5	69,2	76,0	82,7	89,4
1100	16,8	24,2	31,6	39,0	46,4	53,8	61,2	68,6	76,1	83,5	90,9	98,3
1200	18,3	26,3	34,4	42,5	50,6	58,7	66,7	74,8	82,9	91,0	99,1	107,2

The weights on the table are indicative and do not include the filter.

Note!

Weight tables of DSH and DSH with a mask louvre (ML) in stainless steel with pitch spacing of 18, 23 and 28 mm are available in the datasheet.

Product Code

(S)=Model

(A) One stage

(B) Two stages with ISO Coarse 70% panel filter

(W)=Width

200...1500 (1mm step)

(H)=Height

200...1500 (1mm step)

200...1200 (one stage model)

(MA)=Material

(AS) Stainless steel (EN 1.4404)

(AL) Aluminium (Default paint RAL9010)

(FT)=Frame Type

(S) Standard

(D) Duct installation

(ML)=Mask Louver

(N) No

(Y) Yes

(PS)=Profile Spacing

(A) 28mm

(B) 23mm

(C) 18mm

(WA)=Water Drainage

(A) Front

(B) Bottom

(SH)=Service Hatch

(NA) No hatch

(HL) Hatch on left

(HR) Hatch on right

(AC)=Accessories

(ME) Mesh

(MD) Manometric drain trap

(PG) Differential pressure gauge

Code example

DSH/A-1000-1000,MA=AS,FT=S,ML=N,PS=A,WA=A,SH=NA,ZT=N,AC=ME,PG