

# HME – Single duct cabin unit



## Overview

- Recommended pressure range from 0 Pa to 200 Pa
- Airflow range 0 m<sup>3</sup>/h...500 m<sup>3</sup>/h
- Excellent choice to be used together with HFR/M
- Airflow adjustment with control spindle (MSM module)
- Airflow measurement tubes
- Can be used also as exhaust plenum with MEM airflow adjustment device
- MED approved for B-0/B-15 installations

## Additional features with reheat models

- 230 VAC ±10%, 50/60 Hz
- Triac controlled reheating coil(s), adjustable heating power (PWM) 0...100%
- Master/slave functionality: several cabin units can be controlled by one control panel
- Internal fuses included
- All parameters can be set onsite during commissioning by external device or preset at the factory
- All cable connections with fast connectors
- Easily tailored for different types of installations
- 90°C safety switch with state detection and manual reset
- HME cabin unit is supplied with control panel and interconnection cable

# Specification

Halton HME can be used for air distribution and sound attenuation in various applications such as suites and pantries. The unit operates as a plenum box with a balancing and measurement module inside but also fulfils fire safety requirements as standard cabin unit. The supply volume flow rate is determined during commissioning by using the measurement and adjustment device. The airflow measurement tubes and control spindle can be accessed through the unit's outlet. Using the pressure difference readings between the measurement taps and the k coefficient, the corresponding volume flow rate can be calculated. Rotating the control spindle adjusts the volume flow rate until the desired setting is achieved.

# Dimensions

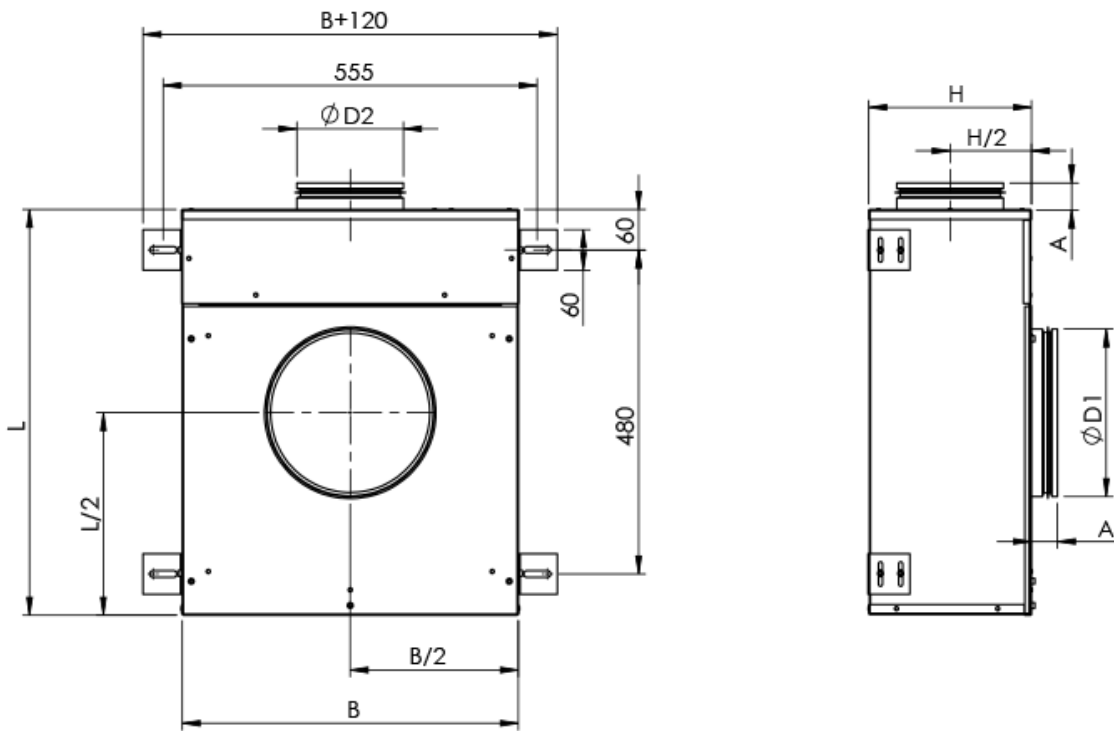

## Unit material thickness 0.5 mm

	L	B	H	A	ØD1 male/ female	ØD2 male
HME-100	590	490	190	45	159/ 161	99
HME-125	590	490	190	45	199/ 201	124
HME-160	590	490	210	45	249/ 251	159

Note: male connection: outer dimension, female connection: inner dimensions. Note: Standard dimensions, modifications possible

## Unit material thickness 0.75/1.0 mm

	L	B	H	A	ØD1 male/ female	ØD2 male
HME-100	600	500	200	40	159/ 161	99
HME-125	600	500	200	40	199/ 201	124
HME-160	600	500	220	40	249/ 251	159

Note: male connection: outer dimension, female connection: inner dimensions. Note: Standard dimensions, modifications possible

## Weights

Casing thickness	HME-100	HME-125	HME-160
0.5 mm	9.5 kg	10 kg	10.5 kg
0.75/1.0 mm	13.5 kg	14 kg	14.5 kg

\*weights with reheater and I/O unit

# Material

PART	MATERIAL
Casing	Hot galvanized steel or EN 1.4404 (AISI316L) as an option
Casing thickness	0.5 mm or 0.75/1.0 mm as an option
Spigots	Hot galvanized steel and EPDM rubber or EN 1.4404 (AISI316L) as an option
Insulation	Mineral wool, s = 20 mm, MED approved or s = 25 mm as an option
Input/output unit	Aluminium/plastic/electronics
Reheat coil	EN 1.4301 (AISI304)
Cables	Halogen-free
Measurement and adjustment module (MSM) (supply units)	Body: Aluminium, Plate: Hot galvanized, Spindle: Stainless steel Tubes: Polypropylene
Adjustment module (MEM) (exhaust units)	Spindle: Stainless steel

## Product Models

### Product options

- For supply (with MSM module)
- For supply with reheater and MSM module
- For exhaust (with MEM module)

### Available reheaters

- Standard reheaters: 400W, 800W, 1200W, 1500W with K01 control package
- Standard reheaters: 400W, 800W, 1200W, 1500W, 1800W with D03 control package

Practical power level may be software adjusted cabin by cabin. Cable and power supply design has to be done according to maximum available heating power.

### Control panel features

Halton Marine HME cabin units are available with three different control panel models; with rotating knob, push buttons with LED bar graph (available as option: IP54) and push buttons with

LCD-display (available as option: IP54).

#### Common features

- Cabin temperature measurement
- Connector for bluetooth / communication adapter to set cabin parameters
- Software for parameter setting and trouble shooting
- Different colour options and custom labeling available as an option
- Delivered with IC-Cable (interconnection cable)
  - For control panel – cabin unit connection
  - Prefabricated with plugs on both ends
  - Cable plug on panel side is designed to be pulled through standard installation pipe
  - Halogen free and flame-retardant
  - Standard length 7 meters. Other lengths available.

#### Control panel with rotating knob

- Temperature adjustment by rotating knob

#### Control panel with push buttons and LED bar graph

- Temperature adjustment by push buttons
- Self diagnose function
- LED intensity control and auto dimming

#### Control panel with push buttons and LCD-display

- Temperature adjustment by buttons
- Self diagnose function
- LCD intensity control and auto dimming
- Display for actual and set point temperatures available as an option
- Time display available as an option
- A customized background picture available as an option
- Several frame options available



Control panel models; push buttons and rotating knob



LCD control panel

## Cabin ventilation configuration table

	UNIT	HMM	HMM	HME	HME	HMF	HMF	HMF	HFR/M	HFR/M	HFR/M	HMR	HMR	HML
TERMINAL UNIT WITH JUNCTION BOX	CONTROL PACKAGE	K01	D03	K01	D03	M00	M01	M02	M00	M01	M02	D21	H21	B00
	Damper	manual	manual	manual	manual	electric	electric	electric	electric	electric	electric	electric	electric	electric
	Airflow measurement and control (VAV, CAV)	no	no	no	no	yes	no	yes	yes	no	yes	yes	yes	yes
	In-box temperature measurement	yes	yes	yes	yes	yes	yes	yes	yes	yes	yes	no	no	yes
	Reheater safety switch, manual reset	yes	yes	yes	yes	yes	yes	yes	yes	yes	yes	no	no	yes
	Safety switch state detection	no	yes	no	yes	yes	yes	yes	yes	yes	yes	no	no	yes
	Spare inputs (balcony door etc.)	no	no	no	no	yes	yes	yes	yes	yes	yes	yes	yes	yes
	Parameter setting by service tool	no	yes	no	yes	yes	yes	yes	yes	yes	yes	yes	yes	yes
CONTROL PANEL	Cabin temperature measurement	yes	yes	yes	yes	yes	yes	yes	yes	yes	yes	yes	yes	yes
	Controller with push buttons, 18 led bar	no	yes	no	yes	yes	no	no	yes	no	no	yes	no	yes
	Controller with knob	yes	no	yes	no	no	yes	yes	no	yes	yes	no	yes	no
	LCD room thermostat	no	optional	no	optional	optional	no	no	optional	no	no	optional	no	optional
	LED intensity control and auto dimming	no	yes	no	yes	yes	no	no	yes	no	no	yes	no	yes
	Self diagnose functionality	no	yes	no	yes	yes	no	no	yes	no	no	yes	no	yes
	Network compatible with adapter	no	yes	no	yes	yes	yes	yes	yes	yes	yes	yes	no	yes
	CO2 sensor available as an option	no	yes	no	yes	yes	no	no	yes	no	no	yes	no	yes
CABLES	Interconnection cable	IC4-X	IC6-X	IC4-X	IC6-X	IC6-X	IC6-X	IC6-X	IC6-X	IC6-X	IC6-X	IC6-X	IC6-X	IC6-X
	Master-Slave cable	MS4-X	MS2-X	MS4-X	MS2-X	MS2-X (MS5-X)	MS3-X	MS3-X	MS2-X (MS5-X)	MS3-X	MS3-X	MS2-X	MS3-X	MS2-X

Please note: HMM and HME units are also available without a control package.

### Manually controlled airflows

Single duct units; HMM, HME

### Pressure dependent units

Single duct units: HMF, HFR/M

### Pressure independent units

Single duct units; HMF, HFR/M, HML

Dual duct units; HMR

## Accessories

### MS-Cable (master-slave cable)

- For master cabin unit – slave cabin unit/units connection
- Prefabricated with plugs on both sides
- Halogen free and flame retarding
- Standard length is 7 meters. Other lengths available as an option.

### Communication adapter

- Bluetooth communication to external device (only with D03 control package)
- For wireless connection to set cabin unit parameters and trouble shooting (only with D03 control package)

### Network adapters (available with D03 control package)

- Network adapter (also available as WiFi) expands a stand-alone unit to network compatible unit (LON or Ethernet network)
- Enables supervision and advanced energy efficiency functions
- For more information, see Halton Networks for cabin ventilation -brochure or contact Halton Marine Sales office.

## Function

Correct airflow for HME unit is set during commissioning by adjusting MSM/MEM device in inlet spigot. MSM/MEM is operated by flexible spindle which is easy to access from outlet.

### Models with reheater

When passenger demands for warmer temperature by using control panel, the controller activates the electric reheater inside the cabin unit. When the required temperature in the cabin is achieved, the reference is held until the temperature demand changes.

## Regulation diagram with reheater

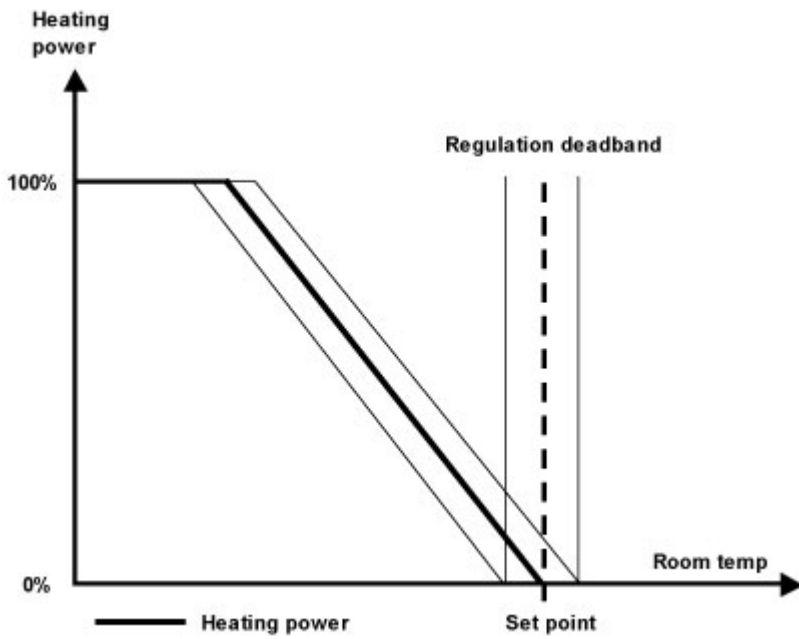

## Operating range for HME without reheater

HME-100	HME-125	HME-160
50 m <sup>3</sup> /h – 200 m <sup>3</sup> /h	50 m <sup>3</sup> /h – 350 m <sup>3</sup> /h	50 m <sup>3</sup> /h – 500 m <sup>3</sup> /h

## Operating range for HME with reheater

HME-100	HME-125	HME-160
100 m <sup>3</sup> /h – 200 m <sup>3</sup> /h	100 m <sup>3</sup> /h – 350 m <sup>3</sup> /h	100 m <sup>3</sup> /h – 500 m <sup>3</sup> /h



# Installation

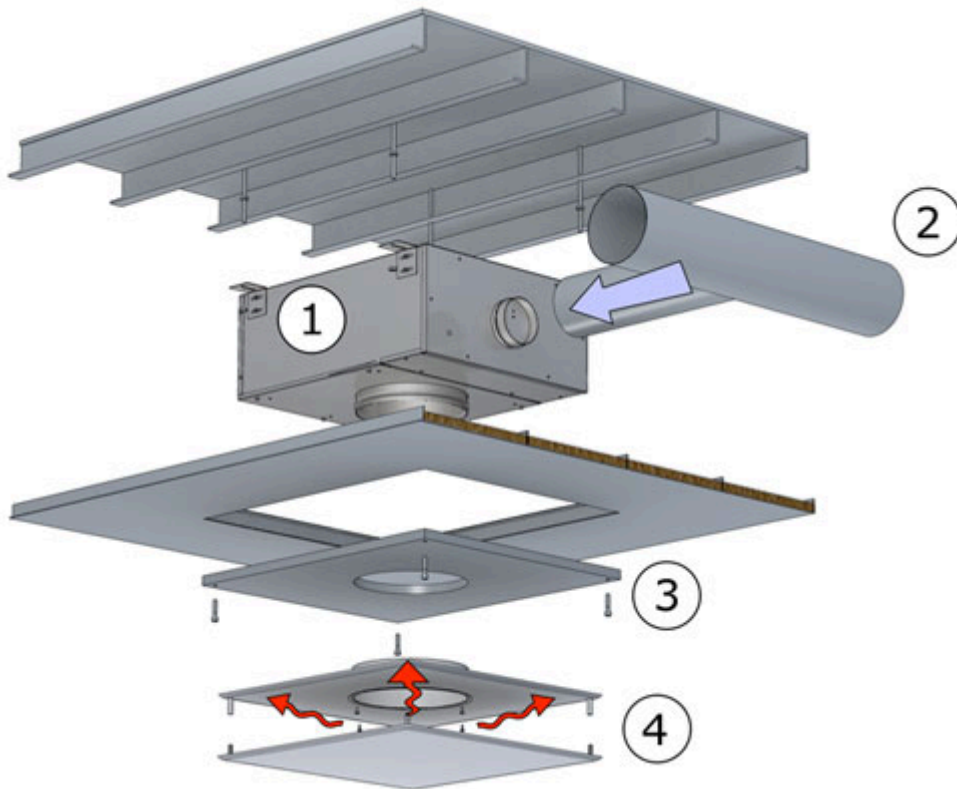

## Cabin unit mounting instruction

Projects requirements and possibilities should be taken into account when designing the installation. For more information on the possibilities contact Halton Marine sales office.

### Main principles in cabin unit installation:

1. Fix cabin unit above false ceiling using thread bar (as seen on picture) or frame installation
2. Connect power supply and IC cable to the unit. (cable installation should be done before this phase, see Interconnection Cable Mounting Instructions). As standard cabin unit has Ensto NAC 31 plug for the power supply (counterpart NAC 32 not include).
3. Connect supply air ducts to cabin unit inlets.
4. Close maintenance / installation hatch.
5. Connect and assemble diffuser to the cabin unit outlet.

## Control Panel mounting instruction

1. Install LRC-1 CP unit back plate to the provided leveled place on the wall.
2. Fasten 3 screws (DIN 7981 or similar, Ø 3mm, **max. head height 3 mm** ) to fix CP unit to its place.

3. Connect LRC-1 interconnection cable to the interconnection connector. Max. allowed tractive force is 30N.
4. Install LRC-1 CP unit front plate to the back plate
5. Fasten the screw in the bottom carefully. Max. Torque 0,3 Nm.

The LRC-1 CP unit should be positioned on the wall inside the room it will regulate. It is advised to avoid direct sunlight or position near heating/cooling source object

## Interconnection Cable mounting instructions

Interconnection cable comes prefabricated with plugs on both sides. To install, draw it through the provided tube from Cabin unit to CP unit (the plug on CP unit is small enough to allow drawing through  $\varnothing$  16 mm tubes). Max. allowed tractive force is 30 N. On the CP side, in the room, leave approximately 8 cm of the cable (the wires) outside the tube. The near end of the tube (CP-unit side) must be blocked (e.g. foam) to prevent condensation and thermal transfers reaching CP unit.

## Safety distances

A required safety distance as illustrated must be taken into account when installing the cabin unit. Airflow measurement accuracy cannot be guaranteed if safety distance is not taken into account.

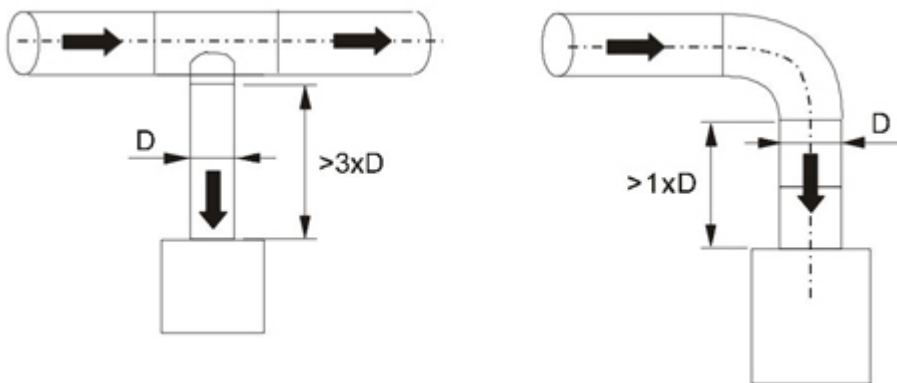

## Adjustment

The supply flow rate is determined by using the measurement and adjustment module MSM. The tubes and control spindle are passed through the diffuser. Measure the differential pressure with a manometer. The flow rate is calculated using the formula below.

$$q_v = k * \sqrt{\Delta p_m}$$

$q_v$  = airflow (m<sup>3</sup>/h)

$k$  = k factor

$\Delta p_m$  = measured pressure (Pa)

K-factors for installations with different safety distances (D = duct diameter)

HME	>8xD	8...3xD
HME-125	29.2	40.7
HME-160	59.8	72.7

Adjust the airflow rate by rotating the control spindle until the desired setting is achieved.  
Replace the tubes and spindle into the plenum.

## Commissioning

All parameters can be preset at the factory according to order. During commissioning all parameters can be modified wirelessly with a PDA handheld device using LRC manager software.

Halton also provides supervision and commissioning services for the projects.

For more information contact Halton Marine Sales office.

## Sound Attenuation

	f(Hz)	63	125	250	500	1000	2000	4000	8000
HME-125	$\Omega$ L(dB)	6,4	11,3	15,9	25,8	34,8	37,9	35,3	34,7
HME-160	$\Omega$ L(dB)	7,2	7,2	17,2	26,7	36,4	40,7	38,5	34,3

$\Omega$ L: Sound attenuation not including end reflection

## Product Code

(S)=Model

(S) Supply (without reheater)

(R) Supply (with reheater)

(E.) Exhaust

(C)=Diameter of inlet connection

160

125

100

(E.)=Diameter of outlet connection

160

200

250

(C2)=Outlet connection type

(A) Male with gasket

(B) Male without gasket

(C.) Female

(CP)=Location of Power Supply Connection

(F) Front end

(S) Side

(NA) No PS connection

(CU)=Control Unit

(K1) K01 (Knob, master)

(K2) K01 (Knob, slave)

(D1) D03 (Push button)

(NA) No control unit

(RH)=Reheat Coil

(NA) No reheater

(S1) Single coil 400 W

(S2) Single coil 800 W

(S3) Single coil 1200 W

(S4) Single coil 1500 W

(ZT)=ETO Processing

(Y) Yes

(N) No

AC=Accessories

Code example

HME/R-160-160,C2=A,CP=F,CU=D1,RH=S1,ZT=Y