

FDH – H0(H120) Kaasutiivis palopelti



Overview

- Type-approved by the most recognized classification societies: class H0(H120) fire damper when suitably insulated. Pre-insulated H0(H60) with ceramic wool at the factory. H0(H120) with additional insulation on site. Blades insulated with ceramic wool
- Blades contain stainless spring steel seals for low leakage in normal conditions and thermal expansion graphite seals (effective from 150 °C) to seal the damper in case of fire
- A closed damper fulfils the requirement of leakage class 3 (EN1751:2014) for size > 300×300 mm. Casing leakage class C
- Fixed frame and blades of stainless steel
- The nominal fuse release temperatures are 50 °C or 74 °C
- With automatic electrical or pneumatic operation system
- Maximum duct pressure for damper construction 5000 Pa and maximum air velocity 15 m/s
- Available as ATEX certified
- SIL 2 safety assessment certificate available for the damper on specific terms

Specification

Halton FDH fire and gas dampers are type-approved class H0(H120) fire and gas dampers for use in offshore and onshore ventilation systems to protect the integrity of bulkheads and decks where they are penetrated by ventilation ducts. The FDH fire and gas dampers can be installed in rectangular or circular ducts. The dampers have a fusible link and they prevent the spread of fire and gases within the ventilation ductwork. When the blades are in an open position, the device does not cause significant pressure loss, noise or flow disturbance. An open-closed beacon is visible on the outside of the damper.

Dimensions and Material Thickness

The FDH fire dampers are manufactured for both rectangular (width B 250-1200 mm with 25 mm division and height H 250-1200 mm with 50 mm division) and circular ducts (Ø250-1250 mm). Non-standard dimensions and flange drilling available on request. Standard flange drilling pattern according to ISO 15138.

Standard frame material thickness 3 mm for size < 600 mm and 5 mm for sizes over 600 mm. Blades are made of two sheets each of them being 1 mm thick. Blades are pre-insulated with ceramic wool.

Standard FDH dimensions (BxH)

B	H	HF
250	250	250
300	300	250
350	350	250
400	400	400
450	450	400
500	500	400
550	550	550
600	600	600
650	650	650
700	700	700
750	750	750
800	800	800
850	850	850
900	900	900
950	950	950
1000	1000	1000
1050	1050	1050
1100	1100	1100
1200	1200	1200

H = nominal height, HF = free height

Blades sizes 150/200/250, 1-6 pcs depending on the size

Flange drilling dimensions according to ISO 15138

DIMENSIONS	ØC	F	P1	P2	BM
If longest side ≤ 350	10	80	75...150	75...150	20
If longest side 351...1000	12	80	75...150	75...150	30
If longest side ≥ 1001	14	80	75...150	75...150	40

Circular flange dimensions and drilling pattern according to ISO 15138

DIMENSIONS	ØC	F
If Ø D ≤ 355	10	40
If Ø D 356...1000	12	50
If Ø D ≥ 1001	14	80

General FDH drawings

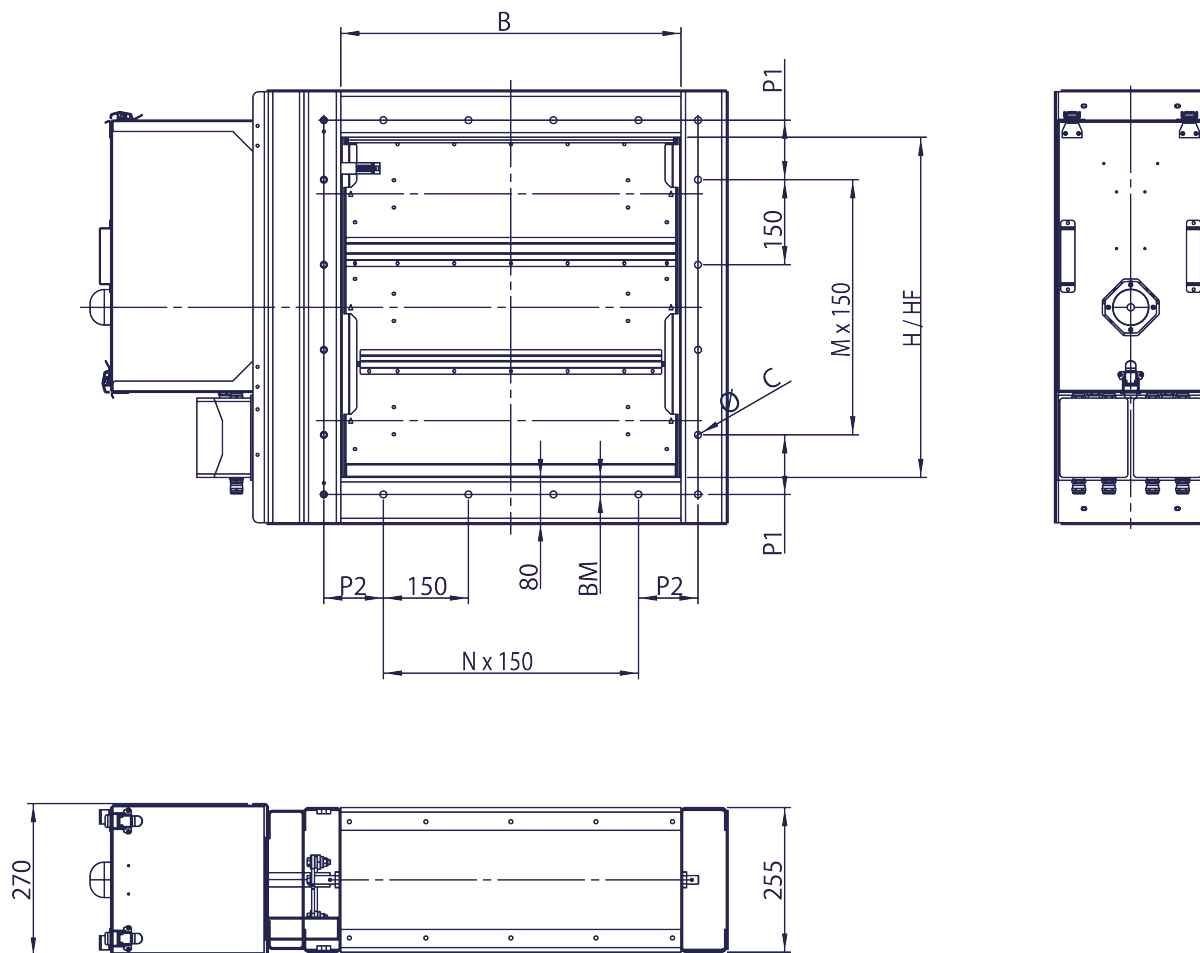

FDH circular connections

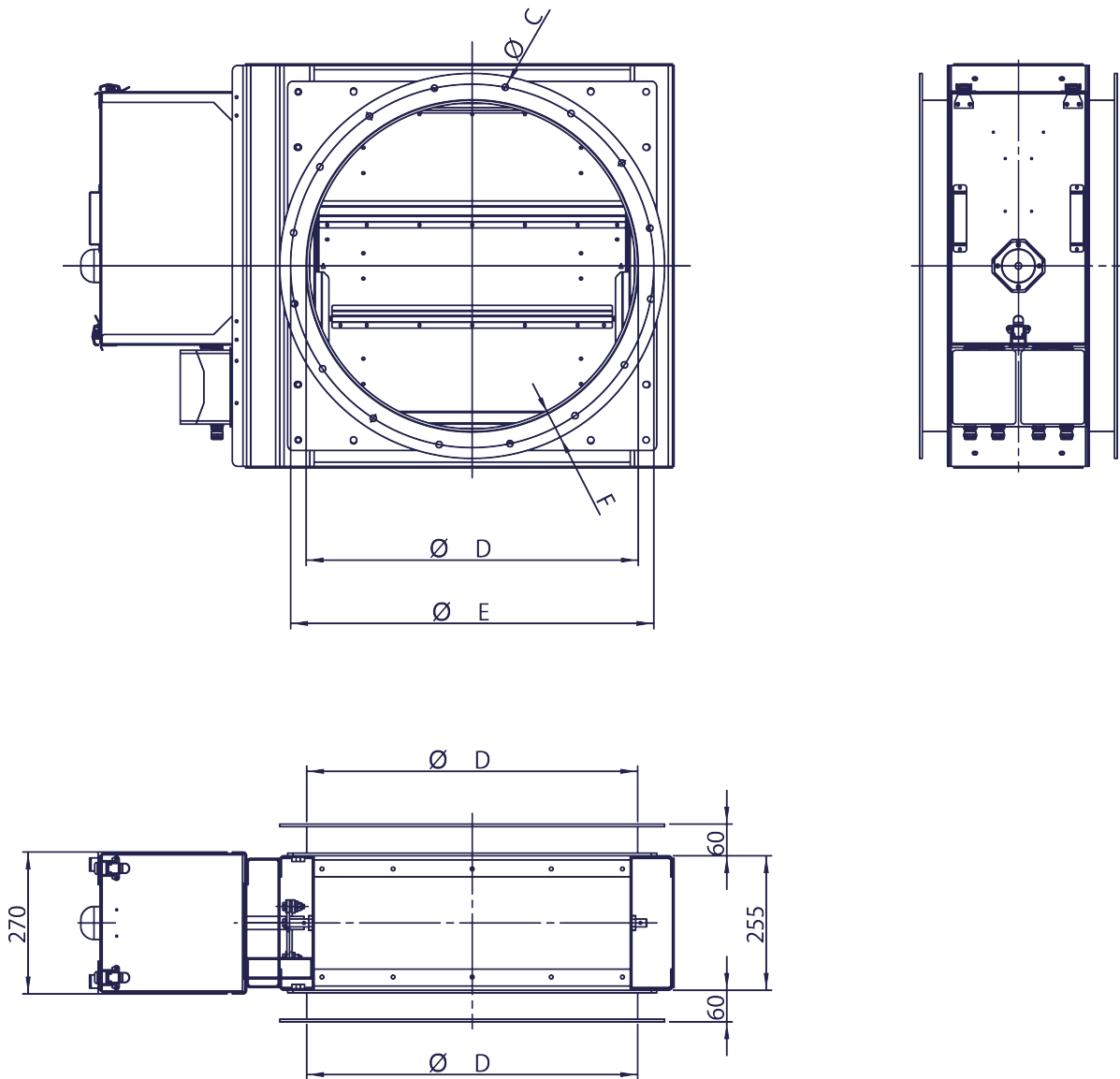

Material and Finishing

PART	MATERIAL	FINISHING
Frame	Stainless steel EN 1.4404 (AISI316L), EN 1.4432 (AISI316L)	—
Blades	Stainless steel EN 1.4404 (AISI316L), EN 1.4432 (AISI316L)	—
Maintenance-free bearings	Stainless steel EN 1.4404 (AISI316L)	—
Shafts	Stainless steel EN 1.4404 (AISI316L)	—

Product Models and Accessories

Halton FDH is available with following actuators:

- FDH-EL: Electrical spring return motor; standard actuators being 24 VAC/DC or 230 VAC or 120 VAC. Depending of the choice of actuator, the actuator might contain built-in open-closed limit switches. Separate junction box included in the EL-model. A wide range of ex-proof actuators available, including a one second closing time function as an option.
- FDH-PNR: Pneumatic rotating actuator. Junction box available as an option.

HSO: Halton Smart Override function for HVAC damper black-start available for PNR and EL models. With automatic reset function when power and/or pneumatic air supply is reinstated.

A wide range of accessories available.

Operation principles

In the event of a temperature rise in ductwork:

- FDH-EL: fusible link releases and cuts off operating voltage to the spring return motor, allowing the spring to close the damper blades. The fire damper opens automatically when the fuse has been changed and the operating voltage to the motor is re-established.
- FDH-PNR: fusible link releases and cuts off operating pressure to the spring return actuator, allowing springs to close the damper blades. The fire damper opens automatically when the fuse has been changed and the pneumatic air supply is re-established.

Weights

STANDARD HALTON MARINE FDH DAMPERS (KG) without an actuator*

H/ HEIGHT (mm)	B/WIDTH (mm)									
	300	400	500	600	700	800	900	1000	1100	1200
300	46	51	57	62	83	90	97	103	110	117
400	54	59	65	71	94	102	109	116	124	131
500	61	68	74	81	105	113	121	129	137	145
600	67	73	80	86	112	120	128	136	144	152
700	90	98	107	115	123	132	140	149	157	165
800	97	105	113	122	130	139	147	155	164	172
900	105	114	123	132	141	150	159	168	177	186
1000	112	121	130	139	148	157	166	175	184	193
1100	121	131	140	150	159	169	178	188	197	207
1200	128	138	147	157	166	176	185	195	204	214

*Approximate weights without an actuator.

- Flange height is always 80 mm, flange drilling pattern is according to ISO 15138
- Frame thickness is 3 mm (longest side up to 600 mm) and 5 mm (longest side 601 mm or more)

Approximate weights of pneumatic rotary actuator Air Torque FDH-PNR:

- AT101 as aluminium: +1.8 kg
- AT104 as stainless steel: +4.0 kg
- AT201 as aluminium: +3.2kg
- AT204 as stainless steel: +6.4 kg
- AT301 as aluminium: +6.0 kg
- AT304 as stainless steel: +13.3 kg

Other actuators available on request.

Electric rotary actuator Schischek ExMax or InMax

ACTUATOR OPTIONS	CLOSING TIME	MATERIAL	WEIGHT (APPR.)
Ex/InMax-15-SF	3 seconds	Aluminium	3,5 kg
Ex/InMax-15-SF	3 seconds	Stainless steel	7,0 kg
Ex/InMax-15-SF1	1 second	Aluminium	3,5 kg
Ex/InMax-15-SF1	1 second	Stainless steel	7,0 kg
Ex/InMax-30-SF3	3 second	Aluminium	9,5 kg
Ex/InMax-50-SF3	3 second	Aluminium	9,5 kg

Installation

Installation on wall or roof.

At wall installation the blade orientation must always be in horizontal plane.

Installation and maintenance instructions are with each fire damper delivery. Copies of Operation and Maintenance manuals are available from Halton Marine Sales offices and distributors.

Product Code