

# Private: Halton Vita Lab VVI – Measurement unit

## Overview

## Halton Vita Lab

## VVI – airflow measurement unit

### Halton VVI is a stainless steel fume cupboard measuring unit for Halton Vita Lab Solo systems:

- For single exhaust fan ventilation design applications (controls a single fume cupboard exhaust fan)
- For exhaust installations
- Delivered with an integrated control box containing a differential pressure sensor for airflow measurement and a Halton VLC fume cupboard controller

## Product characteristics

- Circular inlet, circular outlet
- Corrosion-proof stainless steel
- Casing tightness fulfils class C (EN 1751)
- Inlet and outlet spigots with integral rubber gaskets
- Airflow measurement with measurement probe
- Operating range with ambient temperature of 0-50 °C
- Ambient relative humidity <95%, non-condensing

## Product models and options

- Available sizes: 100, 125, 160, 200, 250, 315, 400, 500

The Halton Vita Lab Solo Design Guide available from Halton Sales provides you with more information about selecting the right configuration and exhaust unit for your Halton Vita Lab solution.

However, as all designs vary, close cooperation with Halton is recommended in order to ensure the best results.

## Dimensions

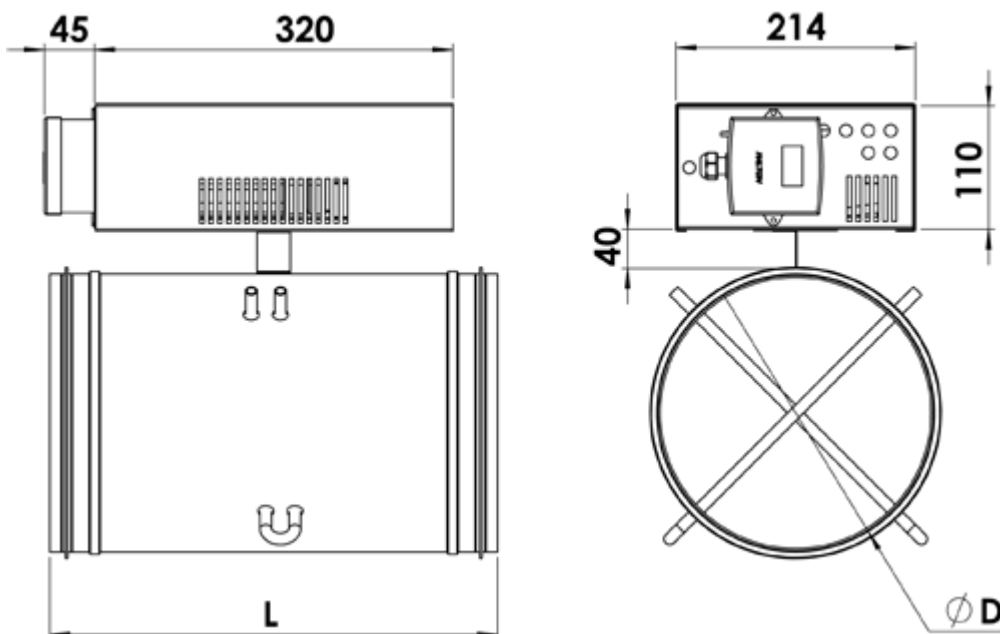

NS	D	L
100	98	400
125	123	
160	158	
200	198	
250	248	
315	313	
400	398	
500	498	

## Airflow range per size

Minimum and maximum airflow ranges for the different sizes in l/s and m<sup>3</sup>/h (max is based on measuring unit velocity of 8 m/s):

NS	Qmin	Q for 8m/s
100	8 l/s	64 l/s
	29 m <sup>3</sup> /h	230 m <sup>3</sup> /h
125	13 l/s	104 l/s
	47 m <sup>3</sup> /h	374 m <sup>3</sup> /h
160	20 l/s	160 l/s
	72 m <sup>3</sup> /h	576 m <sup>3</sup> /h
200	32 l/s	256 l/s
	115 m <sup>3</sup> /h	922 m <sup>3</sup> /h
250	49 l/s	392 l/s
	176 m <sup>3</sup> /h	1411 m <sup>3</sup> /h
315	78 l/s	624 l/s
	281 m <sup>3</sup> /h	2246 m <sup>3</sup> /h
400	126 l/s	1008 l/s
	454 m <sup>3</sup> /h	3629 m <sup>3</sup> /h
500	197 l/s	1576 l/s
	709 m <sup>3</sup> /h	5674 m <sup>3</sup> /h

# Material

Part	Material
Casing	Stainless steel (AISI 316)
Measurement pros	Aluminium
Tube Connectors	Polyacetal
Flexible tubes	Silicone
Control box	Galvanised steel (Control option: CB=CB1)

# Function

The Halton Vita Lab Solo measuring units maintain the required airflow in the fume cupboard, regardless of variation in the conditions, through accurate measurement and airflow control.

The measuring unit is controlled by the Halton VLC fume cupboard controller (premounted on the unit). The VLC retrieves the measured sensor values of the Halton Vita Lab Solo system and compares them with the assigned setpoint. The differential pressure sensor integrated in the measuring unit measures the pressure in the exhaust unit with a measurement probe and calculates the airflow rate. An exhaust fan and a frequency inverter (not provided by Halton) control the exhaust airflow rate.

Based on the calculations, the VLC then adapts the damper position or frequency using a PID control in order to maintain a constant face velocity. If the airflow does not reach the predefined setpoint, an audio-visual alarm is triggered.

For more information about the operation of the measuring unit as part of the Halton Vita Lab Solo systems, see the Halton Vita Lab Solo Design Guide available from Halton Sales.

# Installation

The exhaust unit can be installed horizontally, vertically or in any other position without impact on the measurement performance.

The required safety distances must be taken into account when installing the exhaust unit. Install

the unit into the ductwork so the airflow direction through the unit is as indicated (ACD = Air Control Damper):

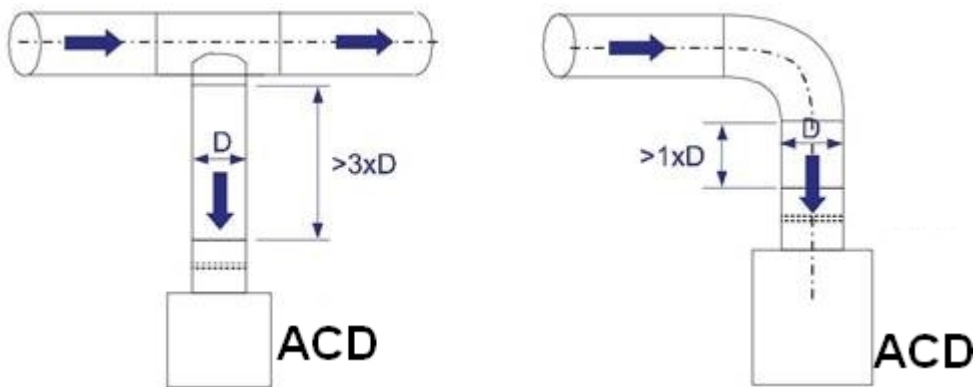

Installation instructions and project-specific wiring diagrams are provided by Halton for all Halton Vita Lab Solo system configurations. For more information, see the Halton Vita Lab Solo Design Guide available from Halton Sales.

## Commissioning

The actual airflow can be calculated as a function of the differential pressure at the measurement probe and the measurement probe k factor as follows:

$$q_v = k * \sqrt{\Delta p_m}$$

$q_v$  Actual airflow rate

$k$  k-value for the product (see table below)

$\Delta p_m$  Differential pressure of the measurement probe [Pa]

NS	k (l/s)	k (m3/h)
100	6.5	23.5
125	10.6	38.2
160	18.3	65.8
200	27.4	98.8
250	44	158.4
315	71.4	256.9
400	117	421.2
500	185.1	666.4

## Specification

Exhaust unit for Halton Vita Lab Solo applications:

Measuring unit used for measuring the exhaust airflow of a single fume cupboard exhaust fan , allowing the control of the frequency inverter of the fan.

Made of 316L stainless steel with measurement probe pipes made of aluminium.

Equipped with integral gaskets and a differential pressure sensor with auto-zero calibration and a digital display.

Short damper construction (<500mm).

Installation possible in any position without impact on the measurement performance.

Integration to fast systems possible due to the differential pressure sensor's standard time constant of 0.5s.

## Product Code

### VVI-D

**D = Diameter of duct connection**

100, 125, 160, 200, 250, 315, 400, 500

## Other options and accessories

MA = Material

SS Stainless steel

**ZT = Tailored product**

N No

## Code example

VVI-100, MA=SS, ZT=N