

Halton Sec SSR – Smoke control damper (AAmulti)



Overview

This multi compartment smoke control damper for automatically (AA) activated systems is one of the lightest in the market. Light construction makes installation easy. The smoke control damper is suitable for vertical and horizontal duct installation in concrete, masonry or lightweight structure. Can also be installed direct to the surface of the structure at the end of the smoke extract duct. Fire resistance class is provided up to EI 120 S requirements

Features

- Supplied with electrical non-spring return actuator (24 V or 230 V)
- Installation to multi zone fire compartment with automatically activated systems (AA)
- Standard sizes from 200×200 mm up to 1500×800 mm are available
- Maximum air speed through smoke control damper in open position is 15 m/s
- Suitability for use in smoke extraction ducts with a maximum of 1500 Pa under pressure
- Frame construction is galvanised steel as standard. Stainless steel options available on request.
- No spare parts or additional installation frames needed, regardless of installation method

Installation options

- Suitability for wall or floor/ceiling installation in vertical or horizontal position
- CE marked for installation in concrete, masonry or lightweight structures with fire resistance

classes of EI 120, EI 90, EI 60

Standards

This product complies with the following standards:

- CE certified according to product standard EN 12101-8
- Fire classification according to EN 13501-4 standard
EI 120 (v_{ew}- h_{ow}- i↔o) S 1500C₁₀₀₀₀ AAMulti
- Fire testing according to EN 1366-10
- CE certificate of constancy of performance, No: P-1391-CPR-2018/0208
- Declaration of Performance No: 10039-SSR-2019/01/01
- Smoke control damper casing tightness class C according to EN 1751
- Smoke control internal leakage is class 2 according to EN 1751

Dimensions and weight

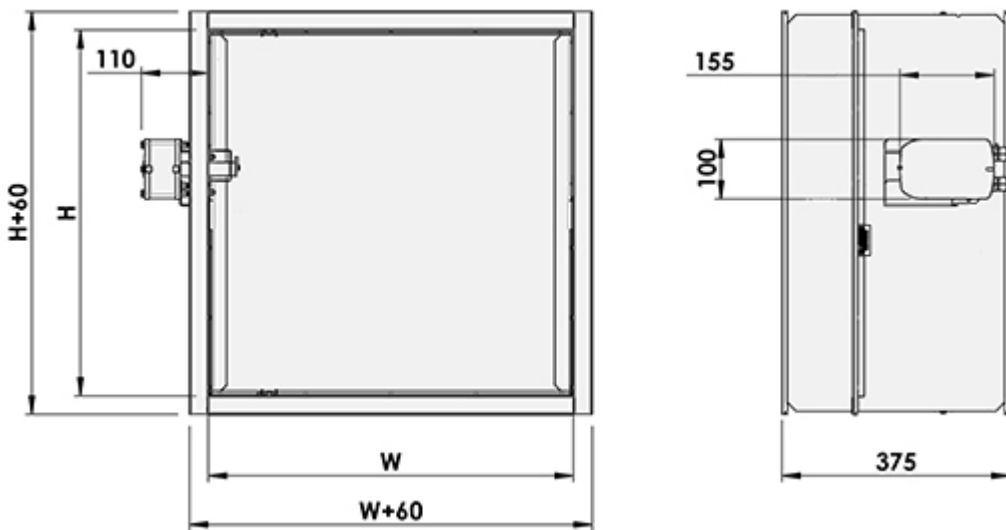

W = Width (mm)

200, 250, 300, 350, 400, 450, 500, 550,
600, 700, 800, +100, ... 1500

H = Height (mm)

200, 250, 300, 350, 400, 450, 500, 550,
600, 700, 800

Weight (kg)

| H | W | | | | | | | | | | | |
|-----|------|------|------|------|------|------|------|------|------|------|------|------|
| | 200 | 250 | 300 | 350 | 400 | 450 | 500 | 550 | 600 | 700 | 800 | 900 |
| 200 | 12.4 | 13.3 | 14.3 | 15.3 | 16.2 | 17.1 | 18.1 | 19.0 | 20.0 | 21.9 | 23.8 | 25.7 |
| 250 | 13.5 | 14.6 | 15.6 | 16.7 | 17.7 | 18.7 | 19.8 | 20.8 | 21.9 | 24.0 | 26.1 | 28.2 |
| 300 | 14.6 | 15.8 | 16.9 | 18.2 | 19.2 | 20.3 | 21.5 | 22.6 | 23.7 | 26.0 | 28.3 | 30.5 |
| 350 | 15.9 | 17.1 | 18.4 | 19.7 | 20.8 | 22.1 | 23.3 | 24.5 | 25.8 | 28.2 | 30.7 | 33.2 |
| 400 | 16.9 | 18.2 | 19.5 | 21.0 | 22.2 | 23.5 | 24.8 | 26.1 | 27.4 | 30.1 | 32.7 | 35.3 |
| 450 | 18.0 | 19.4 | 20.8 | 22.4 | 23.7 | 25.1 | 26.5 | 27.9 | 29.3 | 32.1 | 34.9 | 37.7 |
| 500 | 19.1 | 20.7 | 22.2 | 23.8 | 25.2 | 26.6 | 28.1 | 29.6 | 31.1 | 34.1 | 37.1 | 40.1 |
| 550 | 20.3 | 21.9 | 23.5 | 25.2 | 26.6 | 28.2 | 29.8 | 31.4 | 33.0 | 36.2 | 39.3 | 42.5 |
| 600 | 21.4 | 23.1 | 24.8 | 26.6 | 28.1 | 29.8 | 31.5 | 33.2 | 34.8 | 38.2 | 42.6 | 45.9 |
| 700 | – | – | – | – | – | – | – | – | 39.6 | 43.3 | 47.0 | 50.7 |
| 800 | – | – | – | – | – | – | – | – | 43.3 | 47.3 | 51.4 | 55.5 |

| H | W | | | | | |
|-----|------|------|------|------|------|------|
| | 1000 | 1100 | 1200 | 1300 | 1400 | 1500 |
| 200 | 27.6 | – | – | – | – | – |
| 250 | 30.3 | – | – | – | – | – |
| 300 | 32.9 | – | – | – | – | – |
| 350 | 35.8 | – | – | – | – | – |
| 400 | 38.1 | – | – | – | – | – |
| 450 | 40.7 | – | – | – | – | – |
| 500 | 43.4 | – | – | – | – | – |
| 550 | 47.0 | – | – | – | – | – |
| 600 | 49.6 | – | – | – | – | – |
| 700 | 54.9 | 58.6 | 64.1 | 66.9 | 69.7 | 73.4 |
| 800 | 60.1 | 64.2 | 70.3 | 73.4 | 76.4 | 80.5 |

– = Size not available as standard. Please contact Halton Sales.

Structure and materials

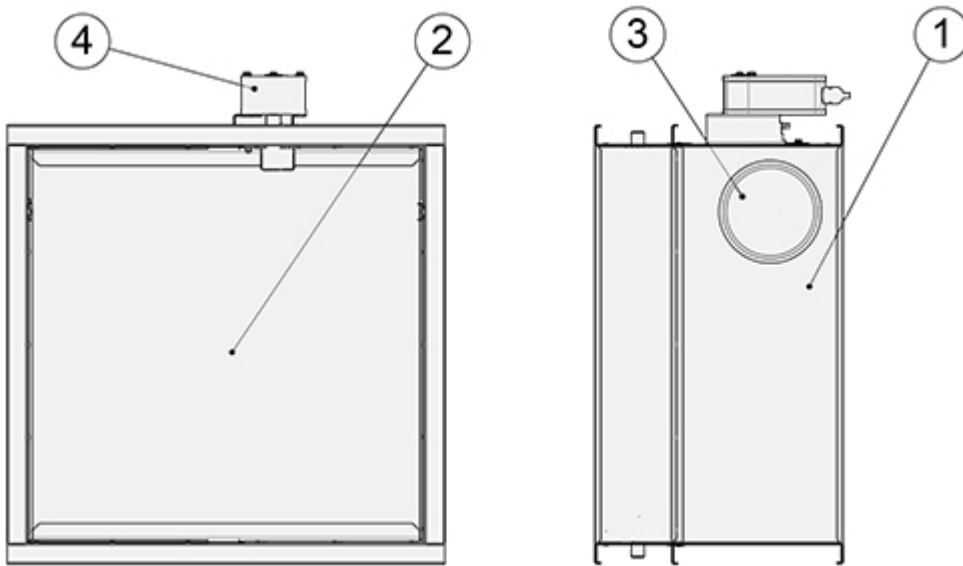

| Key | Part | Material | Note |
|-----|----------------------------|---|--|
| 1 | Casing | Galvanised steel | Stainless steel options available on request |
| 2 | Blade | Asbestos free board made of mineral fibre | |
| 3 | Inspection hatch covering | Galvanised steel | Stainless steel options available on request |
| 4 | Operating model (actuator) | – | Electrical model |

Operating models

Electric actuator

The Halton Sec SSR smoke control damper is equipped with an electric actuator, 24 V or 230 V (no spring return or fuse aloud). The actuator is equipped with built-in limit switches for indicating both open and closed positions.

The smoke control damper must be connected to a common fire alarm or building automation system. It can be used in automatically (AA) activated systems.

| Order code | Operating model | Damper sizes (WxH, mm) | Operating voltage | Limit switch |
|------------|------------------|------------------------|-------------------|--------------|
| R1 | BEN 24 15 Nm | 200×200 – 1500×800 | AC/DC 24 V | ✓ |
| R2 | BEN 230 15 Nm | 200×200 – 1500×800 | AC 230 V | ✓ |

Function

The Halton Sec SSR multi compartment smoke control damper is CE certified for vertical and horizontal orientation. It fulfils the fire resistance class up to **EI 120 (V_{ew} -h_{ow} - i↔o) S 1500C₁₀₀₀₀ AA_{multi}** requirements

Smoke control dampers allow smoke to be extracted from the multi compartment smoke zone by dedicated smoke extraction systems. In case of fire sequence of operation is important, smoke extract fans should not be started before the smoke control dampers are opened.

The smoke control damper must be connected to a common fire alarm or building automation system. It can be used in automatically (AA) activated systems.

The smoke control damper is equipped with an electric actuator 24 V or 230 V (no spring return or fuse aloud). The actuator is equipped with built-in limit switches for both open and closed position.

Installation

Please see/download Installation Guide for this smoke control damper from section Downloads.

Servicing

No regular maintenance is required for the product.

To ensure proper operation of smoke control dampers, an inspection must be carried out regularly according to local building codes. The minimum recommended inspection period is **every 6 months**. Documentation of testing must be saved for future needs.

The smoke control damper must be connected to a common fire alarm or building automation system.

The smoke control damper is equipped with two inspection hatches, enabling the possibility to check the position of the damper blade.

Upon failure during testing of the fire damper, maintenance service shall be ordered from an authorised Halton representative to ensure appropriate operation of the product.

Specification

The multi compartment smoke control damper is CE certified and marked according to the standard EN 12101-8 and fire tested according to the EN 1366-10 standard.

A smoke control damper of maximum fire resistance class **EI 120 (v_{ew}- h_{ow}- i↔o) S 1500C₁₀₀₀₀ AAMulti** requirements.

The smoke control damper casing complies with the tightness requirements for EN 1751 class C. Leakage through closed damper blade fulfils is class 2 according to EN 1751.

The casing of the smoke control damper is made of galvanised or stainless steel. The blade of the smoke control damper is made of fire resistant asbestos free boards (mineral fibre).

The smoke control damper can be installed in either horizontal or vertical position to wall or floor/ceiling.

The actuator is equipped with built-in limit switches for both open and closed position.

The fire damper is equipped with two inspection hatches.

Order code

SSR/W-H; MA-OP-ZT

W = Width of duct connection [mm]

200, 250, 300, 350, 400, 450, 500, 550, 600, +100, ..., 1500

H = Height of duct connection [mm]

200, 250, 300, 350, 400, 450, 500, 550, 600, 700, 800

Other options and accessories

MA = Material

GS Galvanised Steel

OP = Operating model

R1 BEN24, 24 V, 15 Nm

R2 BEN230, 230 V, 15 Nm

ZT = Tailored product

N No

Y Yes (ETO)

Order code example

SSR-400-200, MA=GS, OP=R1, ZT=N