

Halton MSA – Airflow measurement unit



Overview

- Measurement based on differential pressure in measurement probe created by airflow
- Very accurate measurement
- Measurement probes can be removed for cleaning
- Galvanized steel design
- Classification of casing leakage EN 1751 class C.
- Installation independent of airflow direction

Dimensions

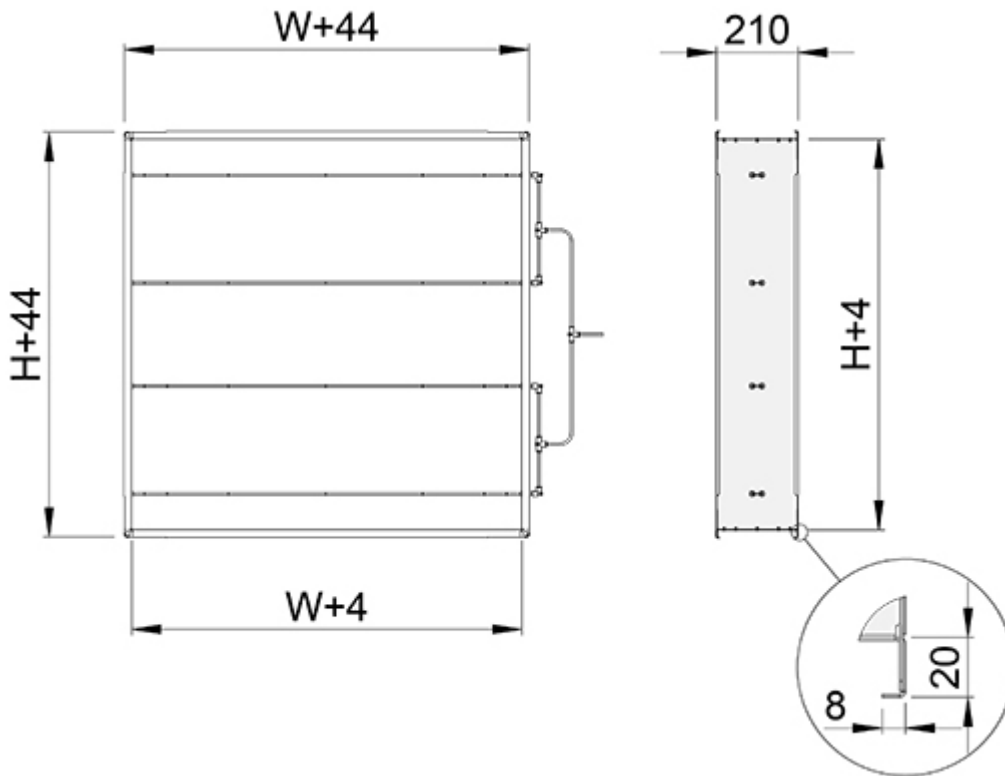

W	H
100, 150, 200, 250 ...1600	100, 150, 200, 250 ...1000

Material

Part	Material
Casing	Galvanised steel
Measurement probe pipes	Aluminium
Measurement tubes	PVC and PP plastic

Function

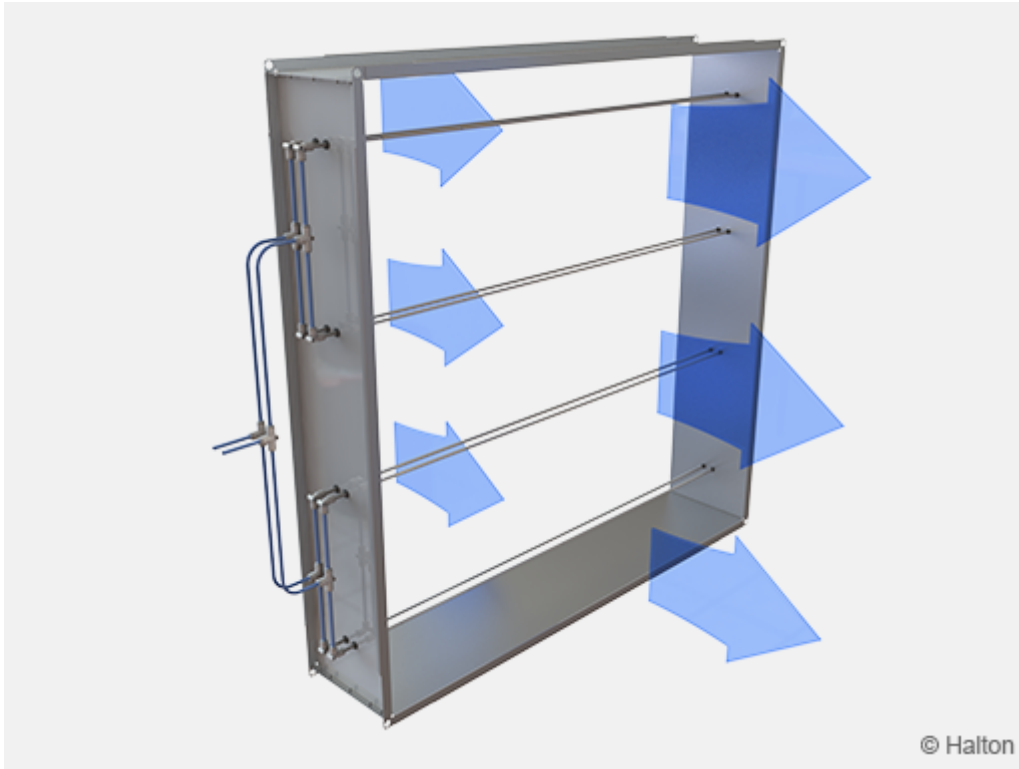

Air flows through the measurement unit, which is installed tightly into the ductwork.

Airflow in a duct creates a pressure difference between the front and rear probes. The corresponding airflow rate can be defined by measuring the pressure difference sensed by the averaging probes.

Installation

Respect the safety distances between the measurement unit and flow disturbances (e.g. bends (2), T-branches (1)) presented in figure below in order to ensure the accuracy of the flow measurement. Installation is independent of airflow direction.

The hydraulic diameter is calculated using the formula below:

$$d_h = 2 \times W \times H / (W + H)$$

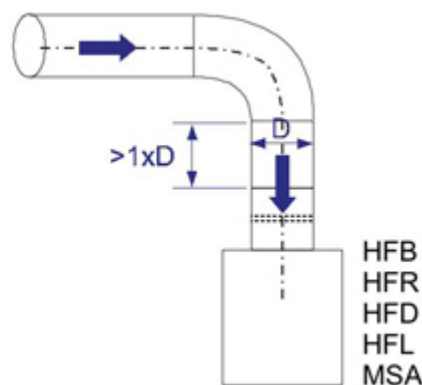
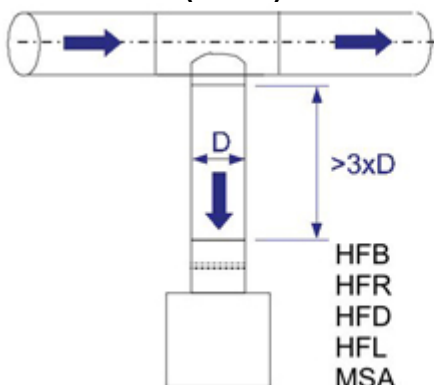

Measurement

Connect the measurement tubes to the measurement taps and to a manometer.

Read the pressure difference between the probes.

The airflow rate is calculated using the formula below or by reading the airflow rate directly from the diagram described in the performance section.

$$q_v = k * \sqrt{\Delta p_m}$$

q_v Calculated airflow rate, l/s
k k-factor (see formula below)
Δp_m Measured differential pressure, Pa

Formula for k-factor calculation:

$$k = W \text{ (mm)} \times H \text{ (mm)} \times 0,001054$$

W Unit width (mm)
H Unit height (mm)

Specification

The casing of the measurement unit is made of galvanised steel.

The measurement probe pipes is made of aluminium.

Measurement shall be based on the principle of dynamic pressure difference created by airflow. Inaccuracy of the measurement method is less than 10 % of the reading.

Order Code

MSA-W-H, MA-ZT

W = Width
100, +50, ..., 1600

H = Height
100, +50, ..., 1000

Other options and Accessories

MA = Material

CS Steel

ZT = Tailored product

N No

Y Yes

Code example

MSA-400-200, MA=CS, ZT=N