

# Halton HFD – Boîte de détente et de mélange

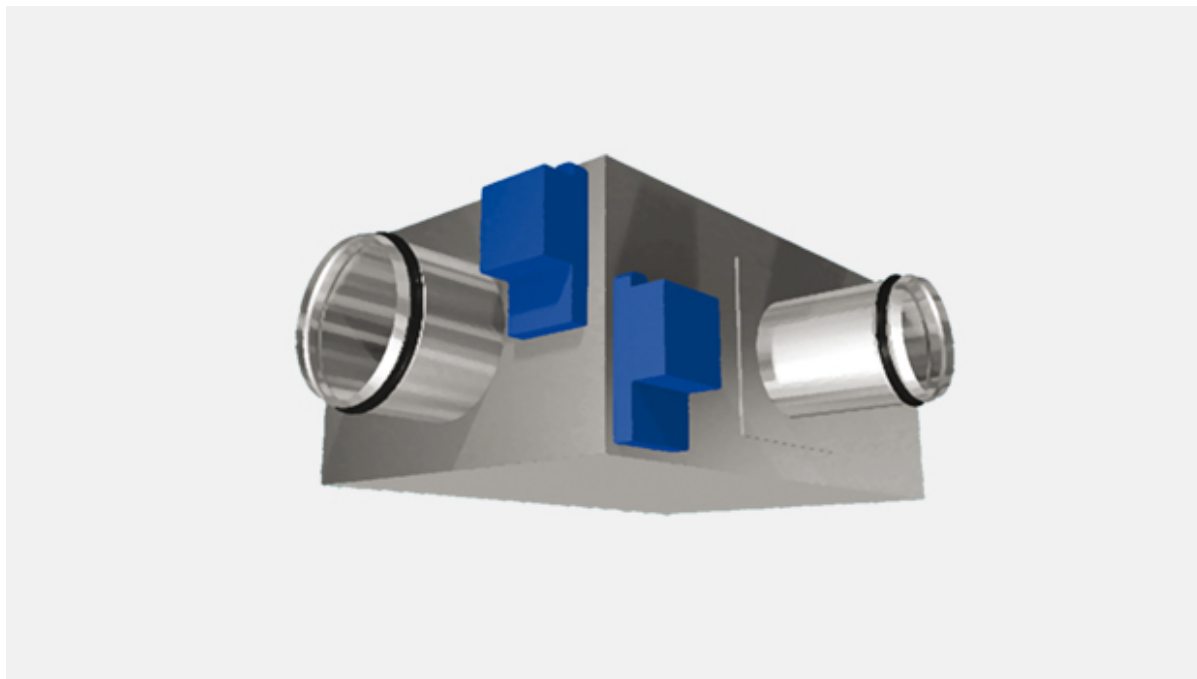

## Présentation

**Arrêt de la production le 1.10.2021**

**-> non remplacé**

- Boîte de détente double tube pour les utilisations en débit variable ou constant
- Fonctionnement indépendant de la pression amont
- Fabrication en acier galvanisé avec isolation
- En position fermée, le clapet est étanche
- Raccordements avec un joint caoutchouc intégré
- Calibration des débits en usine (débits d'air mini/maxi)

## OPTIONS

- Isolation complémentaire
- Silencieux
- Différents plenums de sortie

## Introduction

## Airflow Management Damper for Dual Duct Systems

- Control damper for variable and constant airflow control applications in dual duct systems
- Pressure-independent operation
- Galvanised steel construction with insulation
- Tight shut-off operation at closed damper position
- Circular duct connection equipped with rubber gaskets
- Factory-set airflow range limits (min./max. airflow rates)

## Product Models & Accessories

- Additional insulation option
- Sound attenuator
- Different outlet plenum options

# Dimensions

## DIMENSIONS

### HFD/S, mm

NS	L	L1	L2	W	W1	H	ØD	ØD1
125	720	600	285	486	330	225	125	100
160	720	600	285	486	330	260	160	125
200	720	600	333	611	435	300	200	160
250	720	600	403	641	435	350	250	200
315	1020	900	453	744	500	415	315	250
355	1020	900	525	829	585	455	355	250
400	1020	900	570	1021	715	500	400	315
500	1020	900	713	1296	950	600	500	355

## HFD/B, mm

NS	L	L1	L2	W	W1	H	ØD	ØD1
125	760	640	325	486	410	305	125	100
160	760	640	325	486	410	340	160	125
200	760	640	373	611	515	380	200	160
250	760	640	443	641	515	430	250	200
315	1060	940	453	784	580	495	315	250
355	1060	940	525	869	665	535	355	250
400	1060	940	570	1051	795	580	400	315
500	1060	940	713	1326	1030	680	500	355

### Version

S = Standard insulation, B = Extra insulation

## Material

## MATERIAL AND FINISHING

PART	MATERIAL	NOTE
Casing	Galvanised steel	
Sound attenuation material	Mineral wool	Surface protection layer
Damper blade	Galvanised steel	
Blade gasket	Neoprene	Sizes 100...315
Blade gasket	EPDM rubber	Sizes 400 and 355
Seals between accessories	PVC rubber	
Duct gasket	EPDM rubber	
Measurement probe	Aluminium	

# Function

## FUNCTION

### Variable airflow setting

The cold and warm air ducts are connected to the mixing box. The cold duct connection size is equal to the nominal size of the device, and the warm duct connection is one duct size smaller. The mixing box is equipped with two electric airflow controllers.

In variable airflow application, the warm duct inlet is equipped with the airflow rate measurement probe, and the measurement probe of the outlet of the mixing box measures the total airflow rate. Based on the outlet airflow measurement, the mixed airflow rate is controlled so as to correspond to the total airflow setpoint regardless of the mixing ratio and duct pressure changes. The warm duct airflow rate, and consequently the mixing ratio, is controlled by the room temperature control signal according to the control sequence presented in the figure below. The control signals (heating and total flow) can be received from a stand-alone room controller or from a building management system.

### Constant total airflow setting

The cold and warm air ducts are connected to the mixing box, and both duct connections are of equal size to the nominal size of the unit. The mixing box is equipped with two electric airflow controllers.

In constant airflow application, both duct inlet connections are equipped with airflow measurement probes. The mixing ratio and total airflow rate are controlled by building management system control signals (heating and cooling) so that the desired supply air temperature and airflow rate are obtained as described for the control sequence in the figure below.

## Product Models

# PRODUCT MODELS

The HFD airflow management unit is available in several versions. An integral blade gasket enables tight shut-off operation, and external insulation is used to attenuate radiated sound into the space.

MODEL	FEATURE	COMMENT
HFD/S	Supply air	Standard insulation: 25 mm
HFD/B	Supply air with extra insulation	Insulation: 65 mm

## Control units (CU)

EE = Halton NMV-D2-MP

ED = Belimo VRD2+NM24A-V

EG = Siemens GLB181.1E/3

Controllers EE and ED include a dynamic differential pressure sensor with a low airflow rate through the sensor element. Therefore, these controllers shall not be used in highly contaminated environments. The pressure sensor of the EG unit is based on a membrane with no flow through the sensor element.

Controller ED includes two potentiometers for minimum and maximum airflow setpoint adjustment (ranges: minimum = 0...80% and maximum = 30...100%).

## Sound Attenuators

## SOUND ATTENUATORS

Sound attenuators are available 600 or 900 mm in length, with insulation material of mineral wool. External insulation thickness corresponds to the HFD model, 25 mm or 65 mm.

Attenuator length:

- 600 mm is used for duct size range 100...250 mm.
- 900 mm is used for duct size range 315...500 mm.

SA = Attenuator with baffle

SX = Attenuator without baffle

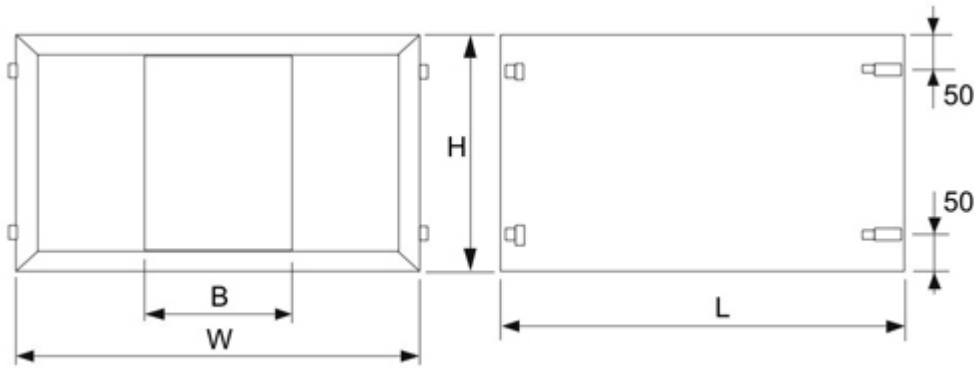

**SA/SX-HFD/S, attenuation material thickness of 25 mm**

NS	L	H	W	B	kg
100	600	225	330	160	10.0
125	600	225	330	160	10.0
160	600	260	330	120	10.0
200	600	300	435	160	11.5
250	600	350	435	120	11.0
315	900	415	500	120	18.0
355	900	455	585	2×120	27.0
400	900	500	715	2×120	33.0
500	900	600	950	3×120	53.5

**SA/SX-HFD/B, attenuation material thickness of 65 mm**

NS	L	H	W	B	kg
100	600	305	410	160	14.0
125	600	305	410	160	14.0
160	600	340	410	120	15.0
200	600	380	515	160	16.5
250	600	430	515	120	16.0
315	900	495	580	120	21.0
355	900	535	665	2×120	32.0
400	900	580	795	2×120	42.0
500	900	680	1030	3×120	63.5

# Connections

## Connections

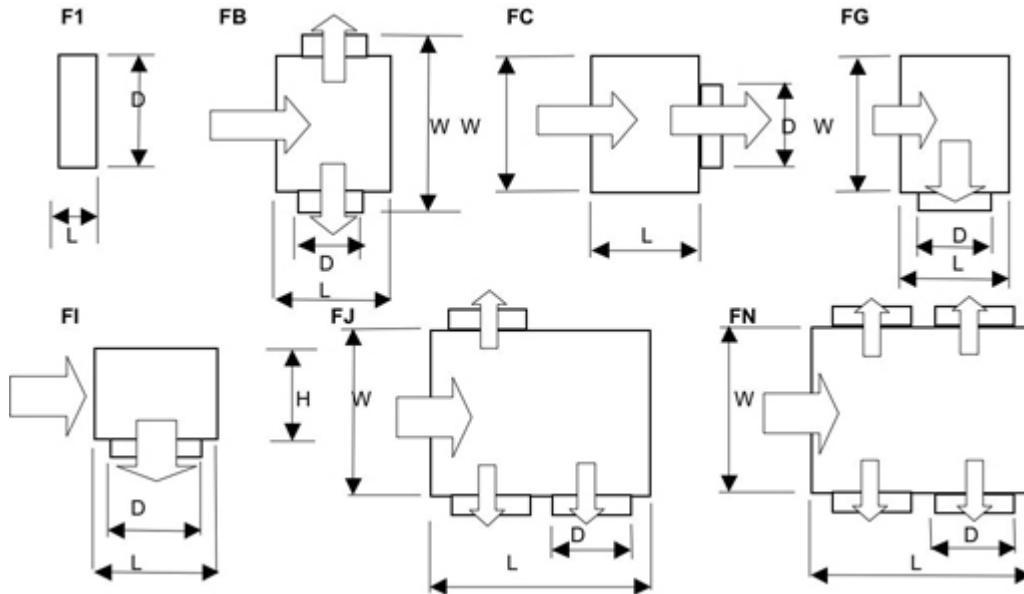

There are eight (8) different outlet connection options available for the HFD dual duct airflow management damper.

For constant airflow applications seven (7) connection models can be used:

- F1: This connection model is developed to connect circular duct directly to the HFD unit, without sound attenuator. If sound attenuator is used, please select the FC connection model in order to allow proper air mixing after sound attenuator.
- FB, FC, FG, FJ and FN: To connect one or more ducts to HFD unit. All these can also be used with sound attenuator.
- FI: This model is used to connect the HFD directly to a diffuser.

For variable airflow applications outlet duct connection model FT is used.

The connection module FT is equipped with a total airflow rate measurement probe.

e = attenuation material thickness [mm]



HFD	e = 25			e = 65			F1			FB			FC			FG		
NS	H	W	H	W	H	W	1 x D	L1	2 x D	L1	1 x D	L1	1 x D	L1	1 x D	L1		
100	225	330	305	410	125	65	125	225	125	200	160	260						
125	225	330	305	410	160	65	125	225	160	200	160	260						
160	260	330	340	410	200	65	160	260	200	200	200	300						
200	300	435	380	515	250	65	200	300	250	200	250	350						
250	350	435	430	515	315	65	250	350	315	200	315	415						
315	415	500	495	580	355	65	315	415	355	200	355	455						
355	455	585	535	665	400	80	355	455	400	200	400	500						
400	500	715	580	795	450	80	400	500	450	200	450	660						
500	600	950	680	1030	500	80	500	660	500	300	500	660						

HFD	e = 25			e = 65			FI			FJ			FN			FT		
NS	H	W	H	W	1 x D	L1	3 x D	L1	4 x D	L1	D	L						
100	225	330	305	410	<=160	260	100	350	100	350	–	–						
125	225	330	305	410	<=200	260	100	350	100	350	125	395						
160	260	330	340	410	<=250	300	125	400	125	400	160	425						
200	300	435	380	515	<=315	350	160	470	160	470	200	425						
250	350	435	430	515	<=355	415	200	550	200	550	250	425						
315	415	500	495	580	<=400	455	250	650	250	650	315	425						
355	455	585	535	665	<=400	500	315	780	315	780	355	465						
400	500	715	580	795	<=500	660	355	860	355	860	400	465						
500	600	950	680	1030	<=500	660	400	950	400	950	500	465						

## Installation

## INSTALLATION

### Safety distances

The airflow control damper is installed with attention to required safety distances (see figure).

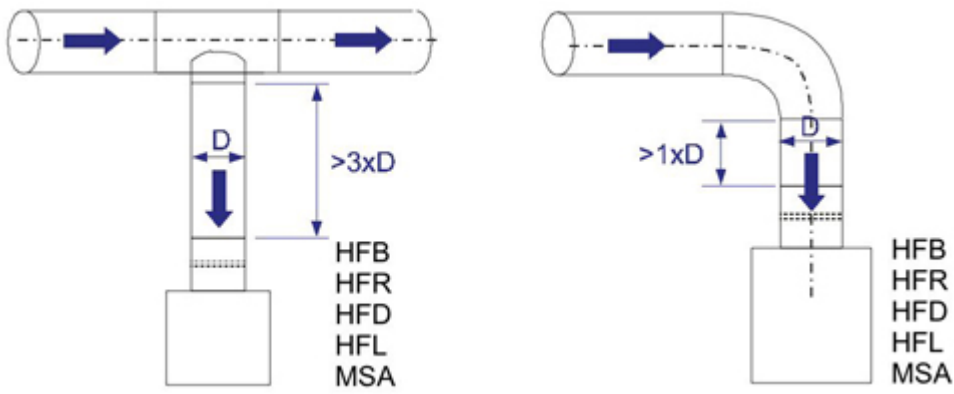

## Wiring

The wiring shall be carried out in accordance with local regulations and by professional technicians.

For the power supply of all control options a safety-isolating transformer shall be used.

**HFD; CU=EE (NMV-D2-MP) – variable or constant airflow control**

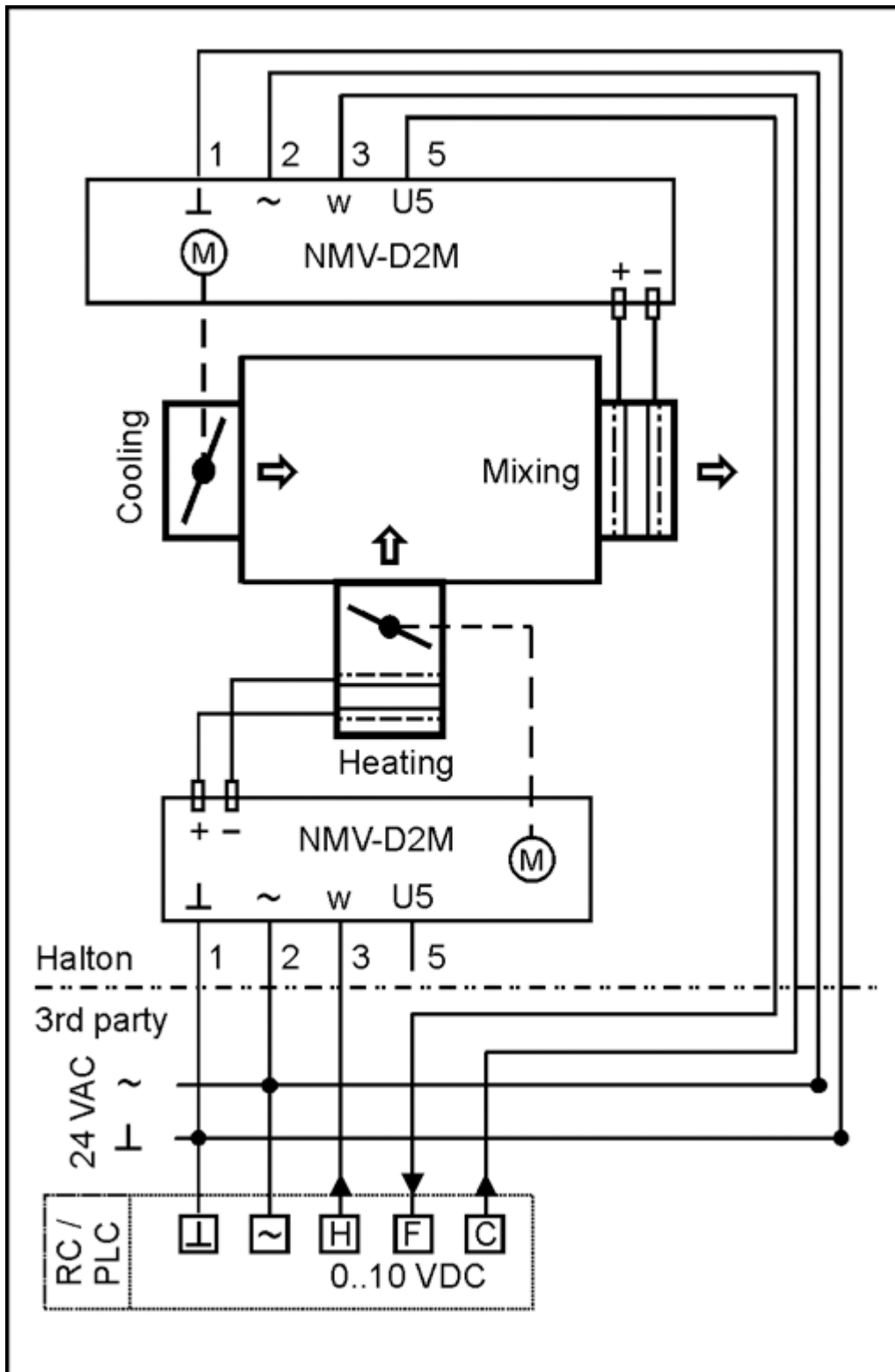

### CODE DESCRIPTION

Halton Delivered by Halton

3 rd party Delivered by a third party

1 (^) 24 VAC system neutral

2 (~) 24 VAC live

3 (w) 0...10-VDC airflow setpoint signal input

5 (U5) 0...10-VDC airflow feedback signal output

RC Room controller

PLC Building management system

C(AO) Airflow setpoint, unit total airflow

H(AO) Airflow setpoint, heating

F(AI) Actual airflow feedback input

HFD; CU=EE (NMV-D2-MP) – variable or constant airflow control

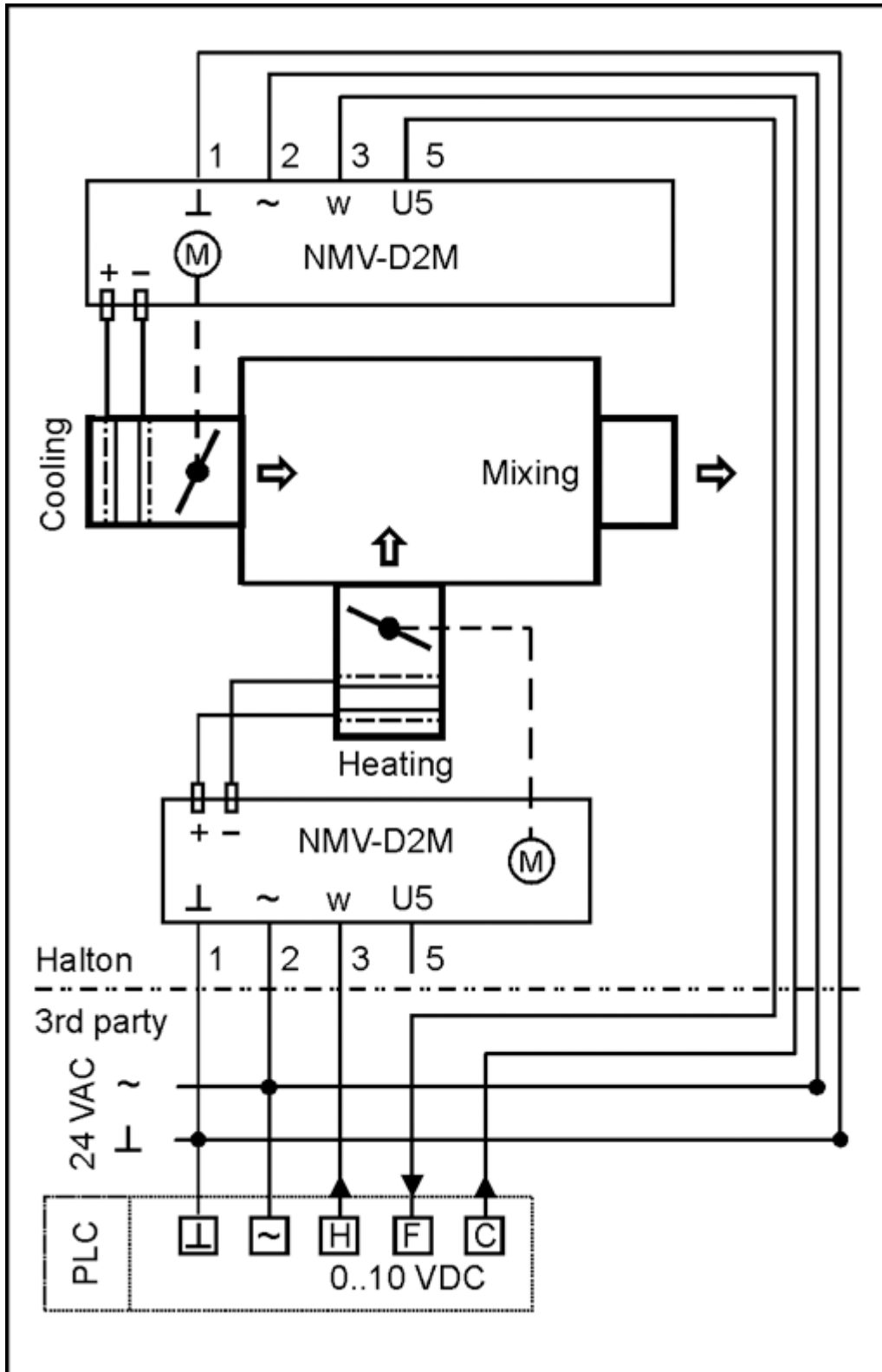

#### CODE DESCRIPTION

Halton Delivered by Halton

3 rd party Delivered by a third party  
 1 ( ^ ) 24 VAC system neutral  
 2 (~) 24 VAC live  
 3 (w) 0...10-VDC airflow setpoint signal input  
 5 (U5) 0...10-VDC airflow feedback signal output  
 RC Room controller  
 PLC Building management system  
 C (AO) Airflow setpoint control signal  
 F (AI) Actual airflow feedback input

## Commissioning

# COMMISSIONING

## Airflow control

Nominal airflow rates of the HFD are presented in the table below.

NS	qv_nominal	NS	qv_nominal
100	73 l/s 263 m <sup>3</sup> /h	315	874 l/s 3145 m <sup>3</sup> /h
125	121 l/s 436 m <sup>3</sup> /h	355	1120 l/s 4031 m <sup>3</sup> /h
160	208 l/s 749 m <sup>3</sup> /h	400	1433 l/s 5159 m <sup>3</sup> /h
200	336 l/s 1210 m <sup>3</sup> /h	500	2267 l/s 8161 m <sup>3</sup> /h
250	539 l/s 1940 m <sup>3</sup> /h		

The actual measured airflow rate (qv) can be defined by the controller feedback signal (U or U5) and airflow controller nominal airflow (qv\_nom).

SIGNAL	FORMULA	CONTROLLER TYPE AND MODE	TERMINALS SYSTEM NEUTRAL	TERMINALS SIGNAL
0...10 VDC	$qv = qv\_nom * U/10$	HFD;CU=EE (NMV-D2-MP), mode 0...10 V HFD;CU=EG (GLB181.1E/3)	1 (GND) 2(G0)	5 (U5) 9 (U)
2...10 VDC	$qv = qv\_nom * (U-2)/8$	HFD;CU=EE (NMV-D2-MP), mode 2...10 V HFD;CU=ED (VRD2+NM24-V)	1 (GND) 1 (GND)	5 (U5) 5 (U5)

The actual airflow rate can also be determined from the pictures below.

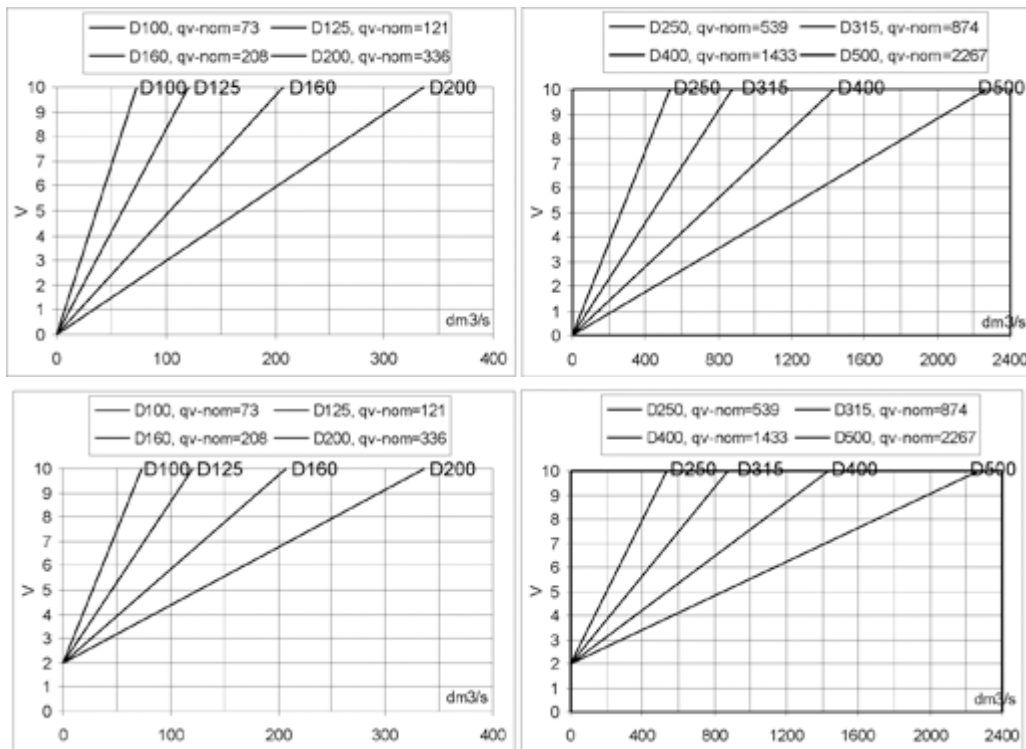

The actual airflow rate can be calculated as a function of differential pressure at the measurement probe and the measurement probe k factor. The proper k factor can be found in an attachment for the product.

$$q_v = k * \sqrt{\Delta P\_m}$$

$q_v$  actual airflow rate [l/s]

$k$  k value of the product

$dP\_m$  differential pressure of measurement probe [Pa]

The EE and ED airflow controllers are equipped with a dynamic pressure differential sensor, and there is a low airflow rate through the pressure sensor. Therefore, a manual manometer cannot be connected in parallel with the airflow controller for differential pressure measurement. If a manometer will be used, the airflow controller power supply shall be switched off in order to stop damper movement during measurement of airflow probe differential pressure. Note that the duct pressure might vary during the measurement.

The EG airflow controller is equipped with a static membrane pressure sensor including automatic zero point calibration, and there is no airflow through the differential pressure sensor of the controller. Therefore, a manual differential measurement manometer can be connected in parallel to the airflow controller (for example with tube T-branches) and both measurements can operate in parallel with continuous control.

## Specification

### SUGGESTED SPECIFICATIONS

The dual duct mixing unit shall be made of galvanised steel with airflow measurement probes of aluminium.

Duct connections  $D = 100...500$  mm shall include airtight neoprene or EPDM rubber gaskets. Damper blades shall include rubber gaskets.

The dual duct unit shall comprise airflow measurements, flow controllers and damper actuators. Design airflow range limits shall be calibrated at the factory.

The casing shall be acoustically insulated with 25-mm-thick mineral wool to avoid airborne noise emission into the duct and radiation of noise through the damper casing. When specified, unit design shall have additional external insulation containing 40 mm of acoustic material and a galvanised steel cover applied over the standard casing.

The dual duct unit shall be equipped with a sound attenuator in order to meet the sound level requirement for the room. As an option, the sound attenuator shall contain a central baffle.

## Product Code

### PRODUCT CODE

**HFD/S-D**

S = Model  
S Standard insulation  
B Extra insulation

**D = Connection size**  
125, 160, 200, 250, 315, 355, 400, 500

## Specifics and accessories

CU = Control unit  
EE NMV-D2-MP (Belimo)  
ED VRD2+NM24A-V (Belimo)  
EG GLB181.1E/3 (Siemens)

### **SA = Sound attenuator**

NA Not assigned  
H1 HFD | Standard insulation | With baffle  
H2 HFD | Standard insulation | Without baffle  
H3 HFD | Extra insulation | With baffle  
H4 HFD | Extra insulation | Without baffle

### **HT = Outlet connection type**

F1 CAV: Outlet plenum | 1 pc., direct duct connection  
FB CAV: Outlet plenum | 2 pcs., side duct connections  
FC CAV: Outlet plenum | 1 pc., back duct connection  
FG CAV: Outlet plenum | 1 pc., side duct connection  
FI CAV: Outlet plenum | 1 pc., side diffuser connection  
FJ CAV: Outlet plenum | 3 pcs., side duct connections  
FN CAV: Outlet plenum | 4 pcs., side duct connections  
FT VAV: Outlet plenum with measurement probe | 1 pc, direct duct connection

## Code example

HFD/S-125, CU=EE, SA=NA, HT=F1, ZT=N