

Private: Halton CBQ – Terminated 1.9.2017



概览

系统中的新风静压箱连接在一起，无需将单独的风管连接到第二个、第三个或第四个冷梁。照明设备采用串联的形式进行连接，因此在安装由多个冷梁组成的模块时，只需使用一条电源/控制电缆。

Halton CBQ 多功能冷梁具有以下优势：

- 缩短了现场安装前置时间（可快速进行装置安装）
- 减少了现场存储的物品数量，进而优化了现场物流
- 只有一个电源，降低了风险
- 场外制造，确保出色的安装质量
- 不采用吊顶，释放了更多空间，有效的增加了房间的空间容量。

吊顶安装和明装的主动式冷梁均可使用机动化的Halton空气质量 (HAQ) 控件。事实上，该控件可以改变冷梁的空气流量，从而在活动人数减少或在建筑内的分布情况发生变化时大量节约系统运行成本。

与生俱来的灵活性可在空间布局和使用情况发生变化时轻松快速地进行调整

- Halton速度控制 (HVC) 可实现单侧速度的调节
- 可使用 HVC 调节速度，从而适应重新定位的隔断墙
- 可使用Halton空气质量 (HAQ) 控件在布局改变时调节送风量

产品型号和配件

- 有同时配有制冷和供热功能的盘管的型号
- 具有不同喷嘴尺寸的型号，适用于不同的风量范围
- 冷梁上集成有嵌入式 T5 照明设备的型号

- 照明设备配有优质光学器件，适用于使用电脑显示器的工作环境
- 可使用电动控制阀来控制送风量的型号
- 配有风量调节阀的型号
- 配件包括电缆槽、填充物、集成式控制阀、执行器、传感器和探测器

Dimensions

Models 1200-2400

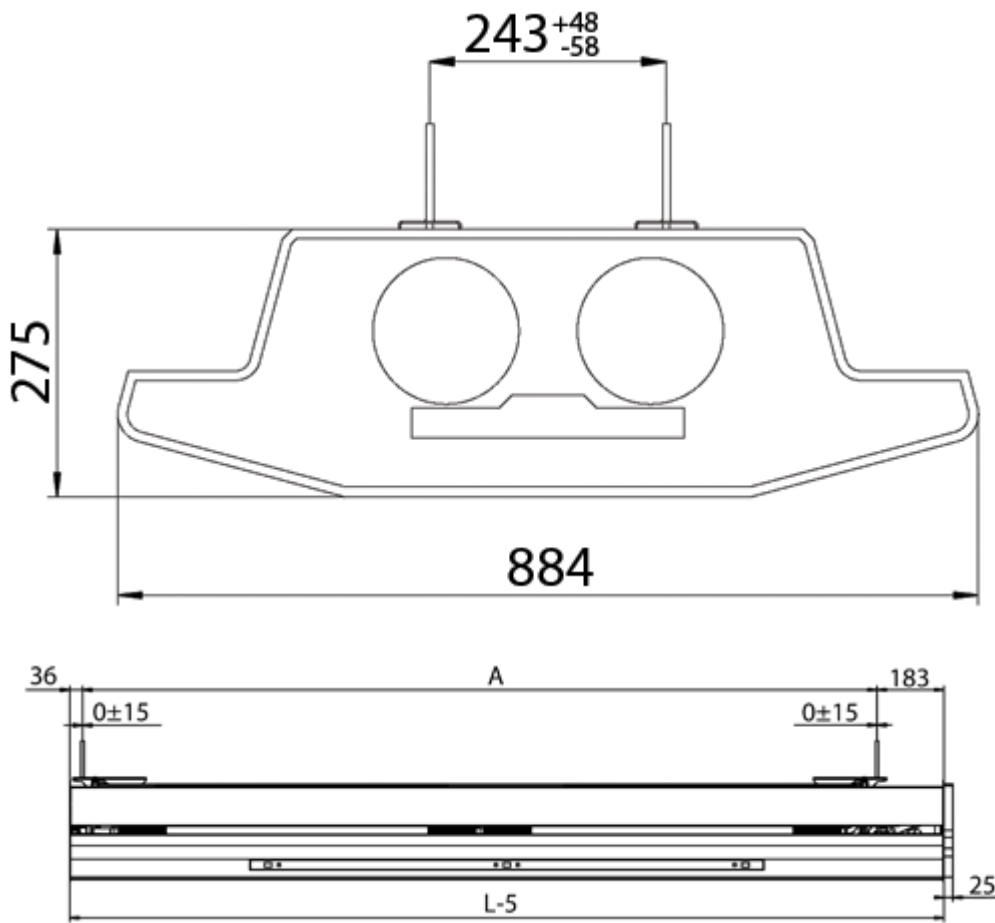

Models 2500-4000

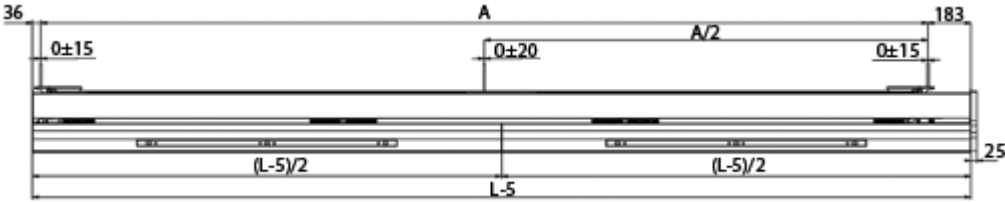
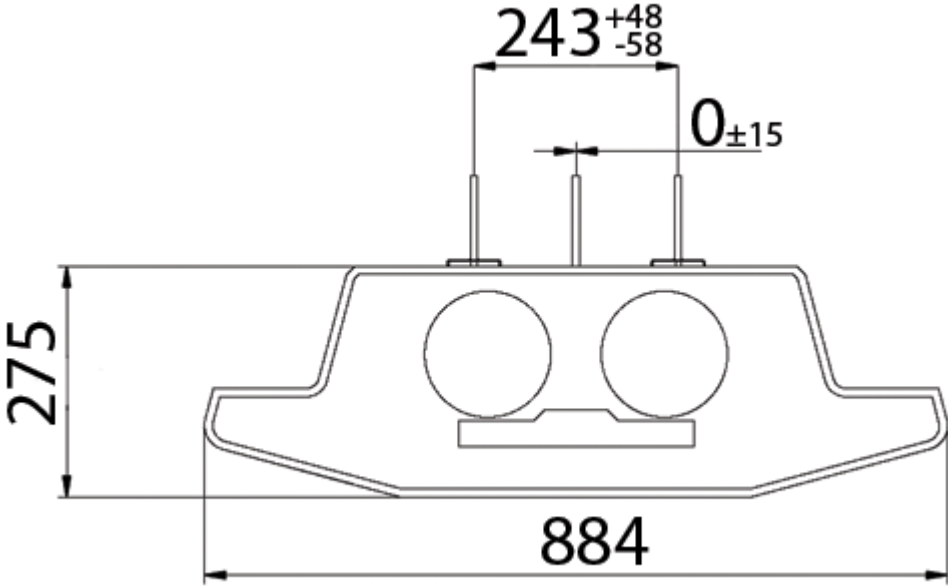

Coil length	800, +100, ..., 3600
L	1200, +100, ..., 4000
A	976, +100, ..., 3776
kg/m	29

Location of coil's cooling and heating pipes

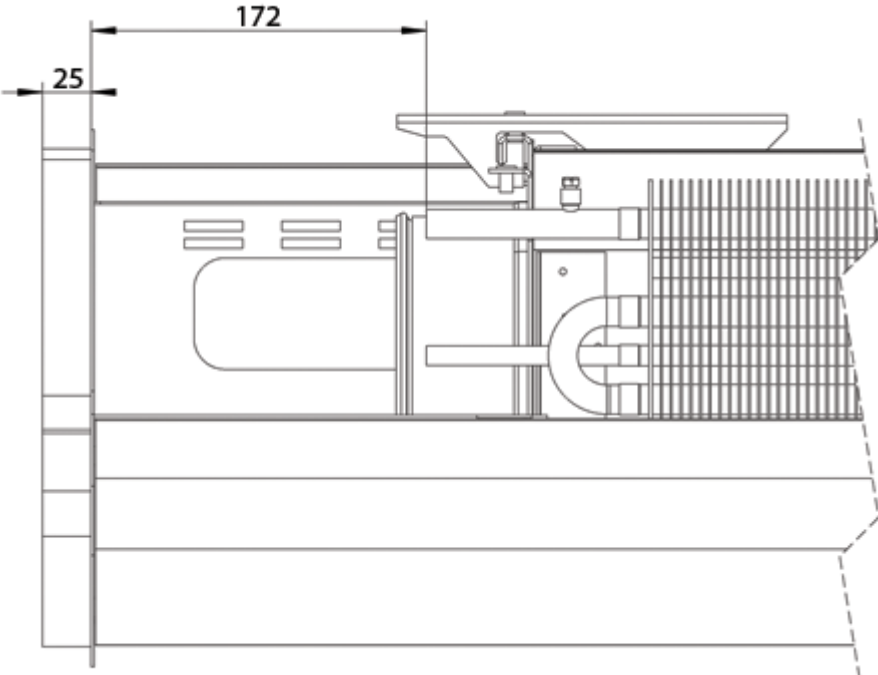
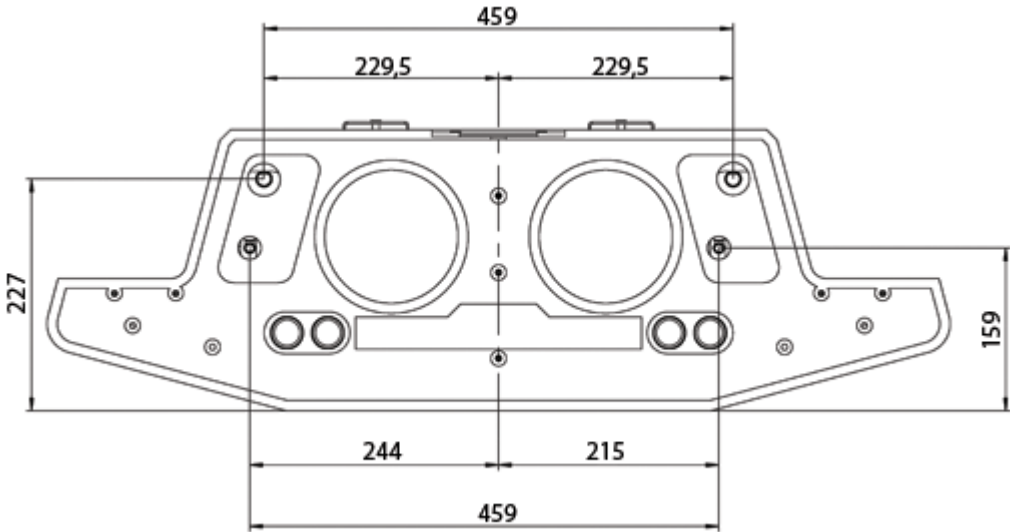

Location of through pipes

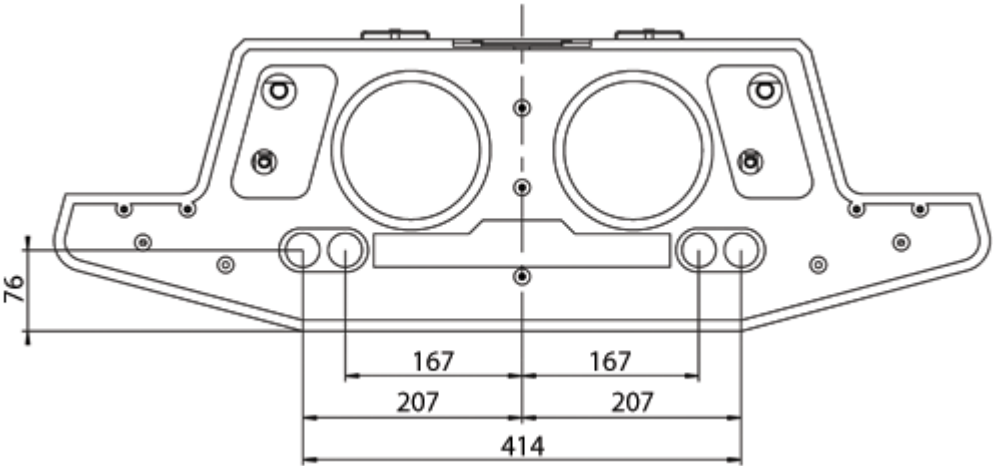

Location of air ducts

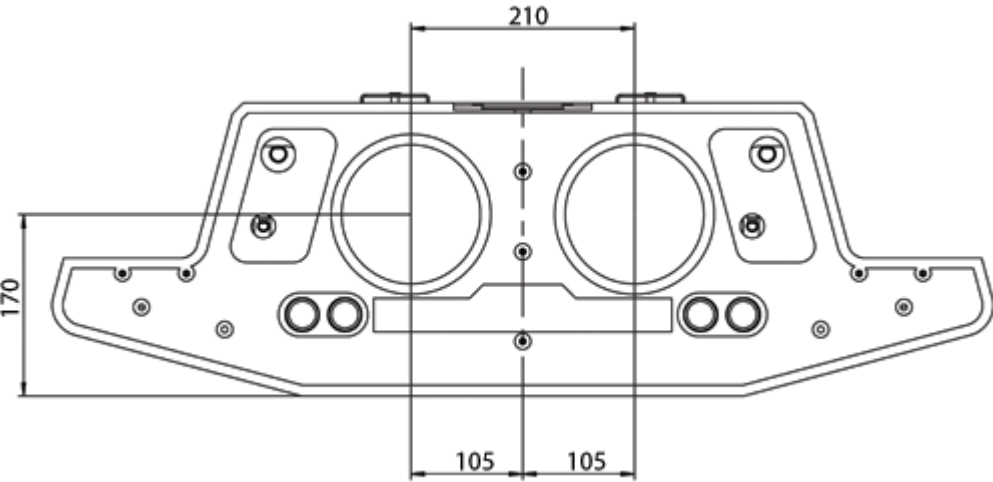

Model with two sections

The front panel of the chilled beam is divided into two equal sections in chilled beams longer than 2400 mm.

Material

Part	Material	Finishing	Note
Front panel	Pre-painted galvanised steel	Polyester-painted, white (RAL 9010/20% gloss)	Special colours available Polyester-epoxy-painted
Side panel	Pre-painted galvanised steel	Polyester-painted, white (RAL 9010/20% gloss)	Special colours available Polyester-epoxy-painted
End panel	Pre-painted galvanised steel	Polyester-painted, white (RAL 9010/20% gloss)	Special colours available Polyester-epoxy-painted
Coil covers	Pre-painted galvanised steel	Polyester-painted, white (RAL 9010/20% gloss)	Special colours available Polyester-epoxy-painted
Cable trays	Galvanised steel		
Supply air plenum	Galvanised steel		
Brackets	Galvanised steel		
Coil pipes	Copper		
Coil fins	Galvanised steel		
Luminaire casing	Steel	Epoxy-painted, white (RAL 9010/20% gloss)	
Reflector	Aluminium		

Cooling/heating water pipe connections are Cu15/Cu10 with wall thickness of 0.9-1.0 mm fulfilling the requirements of European Standard EN 1057:1996.

The maximum operating pressure for chilled/hot water pipework is 1.0 MPa. The supply air duct connection is D 125/125 mm.

Accessories

Accessory model	Code	Description	Note
Cooling coil	TC = C	Coil with chilled water circulation	Cooling copper water pipe connections are \varnothing 15 mm
Combined cooling and heating coil	TC = H	Coil with hot and chilled water circulation	Cooling/heating copper water pipe connections are \varnothing 15/10 mm
Cooling coil with connection in series	TC = G	Coil with chilled water circulation. Coil connected in series	Cooling copper water pipe connections are \varnothing 15 mm
Combined cooling and heating coil with connection in series	TC = I	Coil with hot and chilled water circulation. Coil connected in series.	Cooling/heating copper water pipe connections are \varnothing 15/10 mm
Halton Air Quality control (HAQ damper)	AQ = A	Manual operation	
	AQ = B	Motorised operation Power supply 24 VAC Control signal 0-10 VDC	
	AQ = R	Reservation for retrofitting of HAQ	In retrofitting, HAQ installation is possible
Luminaire	LV = 2C, 4C	Wattage: 28 W	Equipped with electronic ballast according to lighting control
Luminaire	LV = 2D, 4D	Wattage: 35 W	Equipped with electronic ballast according to lighting control
Luminaire	LV = 2E, 4E	Wattage: 21 W	Equipped with electronic ballast according to lighting control
Luminaire	LV = 2M, 4M	Wattage: 14 W	Equipped with electronic ballast according to lighting control
Lighting control	LC = C1	On/Off	Luminaires equipped suitable electronic ballast for basic ON and OFF lighting control. Ensto connectors
	LC = C2	Analog 0-10V	Luminaires equipped suitable electronic ballast for analog 0-10V lighting control. Wieland 6-pole connectors
	LC = C3	DALI	Luminaires equipped suitable

			electronic ballast for DALI lighting control. Wieland 6-pole connectors
Emergency light fitting	EM = L1	First light on left	
	EM = L2	Second light on left	Second light will come only for beams longer than >2400
	EM = R1	First light on right	
	EM = R2	Second light on right	Second light will come only for beams longer than >2400
Control valve and actuators	CV = A1	Danfoss RA-C	Delivered factory fitted or loose. Fitted valves are located inside in front of beams for easy to access.
	CV = A3	Danfoss RA-C + TWA-H NC 24V	
	CV = A5	Danfoss RA-C + TWA-H NC 230V	
	CV = A7	Danfoss AB-QM	
	CV = A9	Danfoss AB-QM + TWA-Z 24V	
	CV = A11	Danfoss AB-QM + TWA-Z 230V	
Temperature sensors	TX = T1	Produal TEKY NTC 10	
	TX = T2	Produal TEKY NTC 20	
	TX = T3	Produal TEKY NTC 1.8	
	TX = T4	Produal TEKY NI 1000	
	TX = T5	Produal TEKY NI 1000-LG	
Carbon dioxide transmitter	Subproduct, CX	Vaisala GMW115	
Condense detector	Subproduct, WX	Condensation monitor EE46	Condensation monitor is located in front of coils

Function

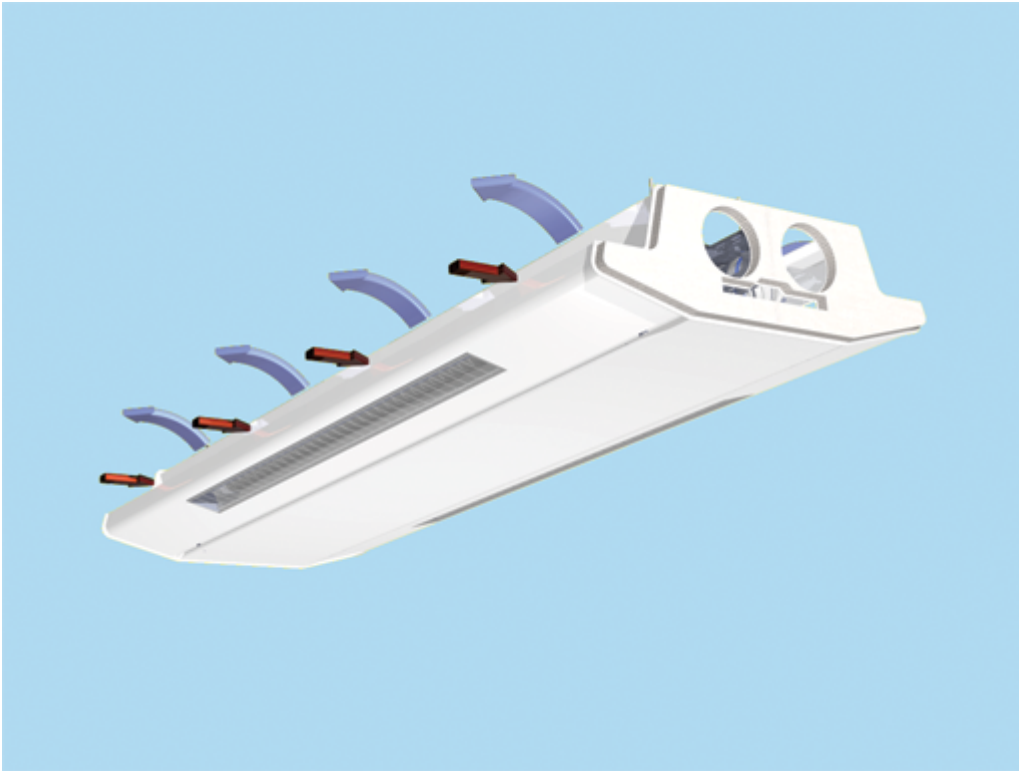

The Halton CBQ unit is an active chilled beam for exposed installation.

The primary supply air enters the plenum of the active chilled beam, from which it is diffused into the room through nozzles and supply slots on the top of the beam. The supply air nozzle jets efficiently induce ambient room air through the heat exchanger, where it is either cooled or heated. The supply air jet is directed horizontally along the ceiling surface. The recommended minimum distance is 600 mm from the wall and 100 mm from the ceiling.

Supply air can be additionally discharged upwards towards the ceiling via the the Halton Air Quality control unit located between the two plenum chambers.

Velocity control in the occupied zone

Halton Velocity Control (HVC) is used for adjusting room air velocity conditions either when room layout is changed (e.g., in cases where the chilled beam is located near the partition wall) or when local, individual velocity conditions need to be altered. Halton velocity control adjustment has an impact on the induced room air flow through the heat exchanger, and therefore it either increases or decreases both the velocities in the occupied zone and the cooling/heating capacity of the chilled beam.

Airflow adjustment and control

The supply air flow of the chilled beam nozzle jets is dependent on effective length, nozzle type and static chamber pressure.

Optional Halton Air Quality (HAQ) control is used for adjusting and/or controlling additional supply air flow rate in a room space. The airflow is dependent on the opening position of the control damper and the static chamber pressure.

Airflow rate control is needed when either room layout or the use of the space is changed (e.g., in a change from office to meeting room). Airflow rate can be adjusted either manually or via automatic demand-based control via a motorised control damper. The actuator can be controlled by a room controller (not included) using a 10-VDC control signal.

A chilled beam equipped with HAQ manual air flow rate adjustment can be retrofitted into motorised demand-based control simply by replacing the HAQ-unit model and connecting the power supply and control signal from a room controller to the actuator.

The chilled beams are recommended to be connected to constant pressure ductwork zone, when:

- the HAQ adjustment has no impact on nozzle jet airflow
- the HAQ adjustment has no impact on either the coil cooling or heating capacities
- the HAQ airflow control has not significant impact to ductwork pressure conditions and respectively to airflow rates of other chilled beams in the same ductwork zone.

Demand-based air quality control and room air temperature control can be realised separately.

The appearance of different units – with constant, adjustable, or variable air flow – is identical.

The Halton Air Quality control unit's position and the selection of chilled beam nozzle size allow adjustment of the primary air flow rate in the space. The air flow adjustment damper (PTS) can be used for balancing air flow.

When a motorised air quality control (HAQ) unit is used, the maximum and minimum air flow rates are adjusted with the stroke limiters of the damper. Separate duct installed air flow adjustment dampers (PTS) is not recommended for use in balancing air flow in this case.

Four different nozzle sizes are available, to enable attaining the minimum supply air flow rate of the chilled beam in a typical room module. Typically, units that are similar (in length or nozzle type) allow effective commissioning of the system.

The primary air flow rate of each beam is adjusted using the Halton Air Quality control unit during the installation and commissioning. There is no need to change or plug nozzles of the chilled beam.

Halton Air Quality control also allows increasing the air flow rate of a chilled beam – e.g., to meet the ventilation requirements of meeting rooms (up to 4 l/s per m², below 35 dB(A)).

Air quality and temperature control

Air quality control of a room space can be arranged, e.g., using a CO₂ sensor when room air temperature is controlled separately by regulating the water flow rate. Alternatively, a temperature sensor can be used for air quality control when air flow rate can be modulated in the first sequence and the water valve starts to open in the second sequence if the temperature exceeds the set point.

In heating mode, it is recommended that the temperature difference between the jet outlet and room air would not be greater than 3 °C. The inlet water temperature of the heat exchanger should not be higher than 35 °C. Optimal heating performance requires an appropriate primary air flow rate. Thus, the air handling unit shall be in operation during heating periods to ensure proper heating performance.

Cooling and heating capacity control

The chilled beam can be equipped in the factory with either a standard control valve or a

combination control valve. Both control valves are operated by a thermal actuator applying the on/off operation principle.

The standard control valve has an adjustable kv-value. The combination control valve has an adjustable maximum limit for the water flow rate and there is a pressure difference measurement for ensuring that the pressure difference (min.: 16 kPa) is sufficient for proper operation. See Document-section for more information.

It is also possible to install the valves behind the duct cover at the building site.

Lighting

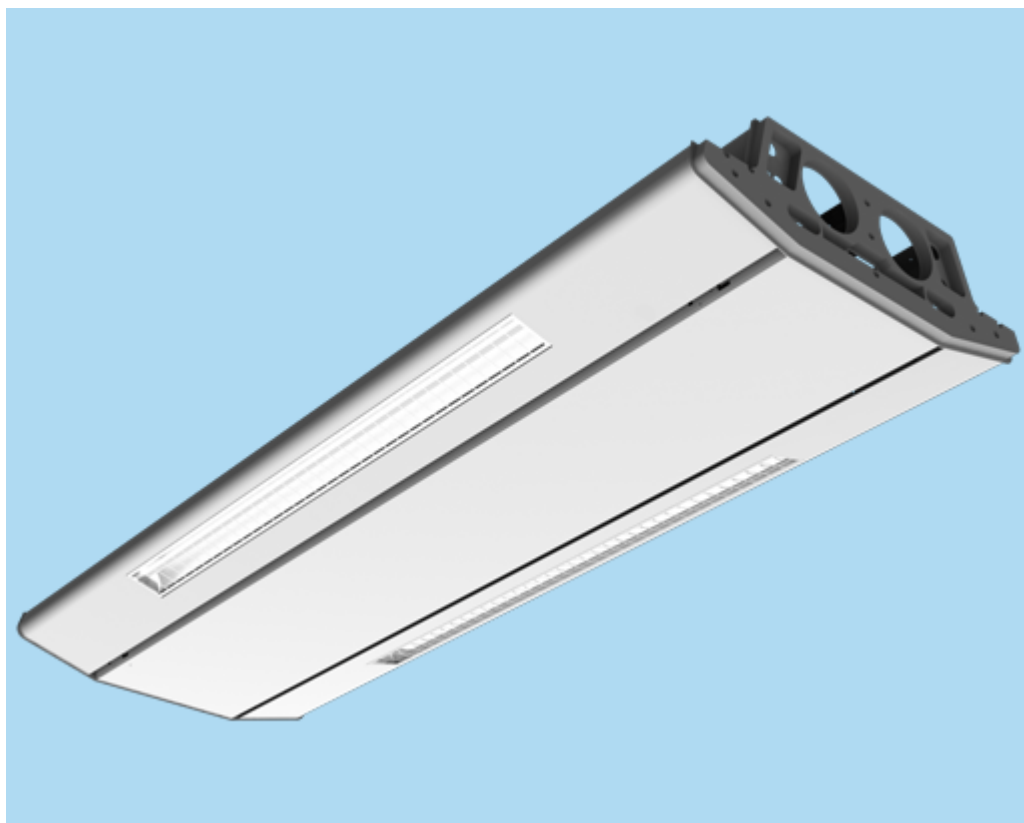

Luminaires for Halton CBQ chilled beams are especially designed high specification recessed direct/indirect luminaires for office applications. The luminaire is designed to suit chilled beam aperture, providing direct/indirect lighting to help meet the Office Lighting Guide LG7 (UK) requirements. Lights are installed and tested in the factory. An extra cable with or without plug is delivered upon request. Standard plug types are Schuko, Enstonet and Wieland.

Lights are manufactured from steel, power coated to match the required finish. Xenoptic satin louver is retained by shootbolt spring fixings. All luminaires come complete with T5 triphosphor lamps with the option of high output or high efficiency.

High frequency control gear DSI, DALI or 1...10 volt dimmable gears are available.

As an option there is also available self-contained emergency lights or central battery/static inverter conversions available, with or without self test system.

Installation

The Halton CBQ unit is suitable for exposed installation in the ceiling, typically lengthwise in the room. It is recommended to position the beam no closer than 600 mm from the wall (1050 mm between wall and unit centreline) and 100 mm from the ceiling using threaded drop rods (8 mm).

Install the main pipelines of the cooling and heating water loops above the level of the chilled beams to enable venting of the pipework.

Connection of motorised air quality (HAQ) control:

Power supply: 24 VAC.

Control signal: 0 ... 10 VDC.

Luminaires

The luminaires within a single chilled beam are interconnected in the factory as standard. The power supply is connected using a plug connector located at the connection end of the beam. An extra cable with or without plug is delivered upon request. Standard plug types are Schuko, Enstonet and Wieland.

Luminaire type	W	21	28	35
Luminaire length	mm	869	1169	1469
Beam nominal length				
One-piece	mm			
	1200	–	–	–
	1300	–	–	–
	1400	–	–	–
	1500	2	–	–
	1600	2	–	–
	1700	2	–	–
	1800	–	2	–
	1900	–	2	–
	2000	–	2	–
	2100	–	–	2
	2200	–	–	2
	2300	–	–	2
	2400	–	–	2
Two-piece				
	2500	–	–	–
	2600	–	–	–
	2700	–	–	–
	2800	–	–	–
	2900	4	–	–
	3000	4	–	–
	3100	4	–	–
	3200	4	–	–
	3300	4	–	–
	3400	4	–	–
	3500	–	4	–
	3600	–	4	–
	3700	–	4	–
	3800	–	4	–

	3900	–	4	–
	4000	–	–	4

Adjustment

Cooling

The recommended cooling water mass flow rate is 0.02...0.10 kg/s, resulting in a temperature rise of 1...4 °C in the heat exchanger. To avoid condensation, the recommended inlet water temperature of the heat exchanger is 14...16 °C.

Heating

The recommended heating water mass flow rate is 0.01...0.04 kg/s, resulting in a temperature drop of 5-15 °C in the heat exchanger. The inlet water temperature of the heat exchanger should not be higher than 35 °C.

Balancing and control of water flow rates

Balance the water flow rates of the chilled beam with adjustment valves installed on the outlet side of the cooling and heating water loops. The cooling capacity and heating capacity of the chilled beam are controlled by regulating the water mass flow rate. The water mass flow rate can be controlled by using an ON/OFF valve or a two- or three-way proportional valve.

Adjustment of supply air flow rate

Each chilled beam is equipped with a measurement taps (2 pcs) for static pressure measurement, which enables fast and accurate measurement of the supply airflow rate through the effective part of the chilled beam. The airflow rate is calculated using the formula below.

Nozzle jet airflow rate q_v

$$q_v = k * l_{eff} * \sqrt{\Delta p_m}$$

l_{eff} = length of the coil, m

Δp_m = average of the measured static pressure of the two chambers [Pa]

Nozzle	k (l/s)	k (m3/h)
A	0.72	2.59
B	0.98	3.53
C	1.38	4.97
D	1.94	6,98

The supply air flow rate of the Halton Air Quality control unit is determined by measuring chilled beam static pressure and reading the opening position of the HAQ unit. The air flow rate is calculated using the formula below.

Air quality control diffuser airflow rate q_{v2}

$$q_v = a * k * \sqrt{\Omega P_m}$$

a = HAQ position

dpm = measured static chamber pressure [Pa]

k (l/s)	k (m ³ /h)
0,31	1,12

Total airflow rate q_v

$$q_v = q_{v1} + q_{v2}$$

Adjustment of the air flow in constant airflow applications

Define the position of HAQ in millimeters that correspond to airflow rate at the actual chamber pressure level.

Adjustment of HAQ is done manually with the help of position scale by adjusting the opening of the unit. It is possible to verify the opening in millimeters on the position scale.

In order to ensure accurate adjustment it is recommended to adjust HAQ-position and in the same time read the targeted chamber pressure using the manometer.

It is also possible to remove the HAQ-unit from the frame by opening two knurled-head screws (4) for the adjustment.

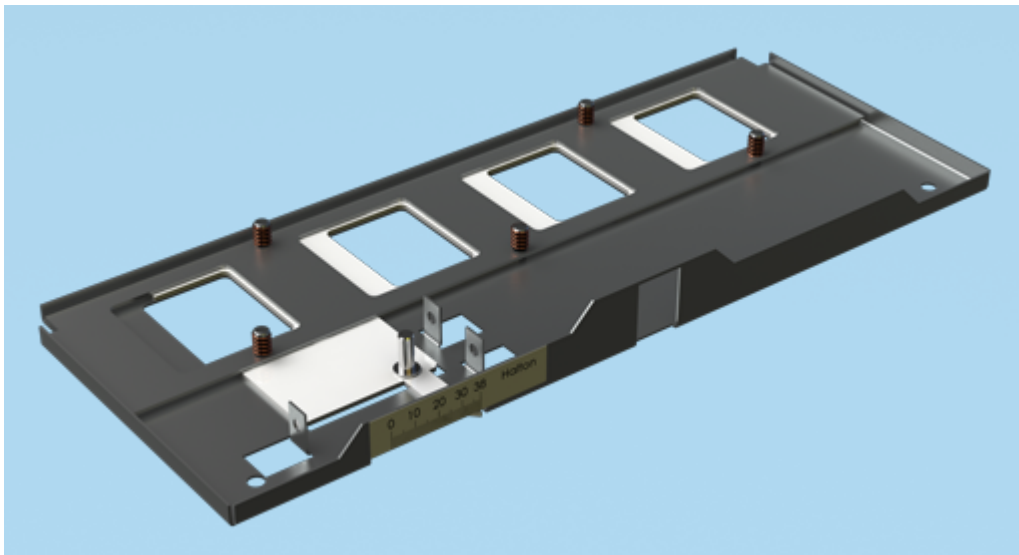

Manual HAQ

Adjustment of the air flow range in variable-air-flow applications

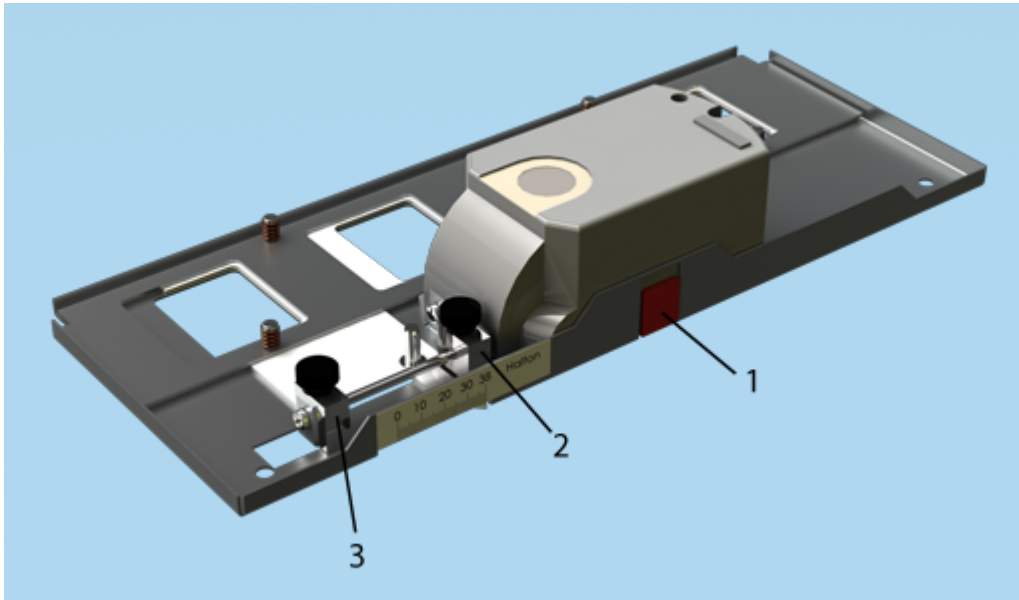

Motorised HAQ

1. Release of the actuator
2. Restriction of the max. opening
3. Restriction of the min. opening

Switch-off the power supply of the actuator.

Disengage the actuator gear into manual override position by releasing the knob.

Define the maximum and minimum positions, in millimeters that correspond to maximum and minimum air flow rates at the actual chamber pressure level. The maximum and minimum positions are adjusted with two screws (2,3). It is possible to verify the opening in millimeters on the position scale.

Switch on the power supply (24 VAC) of the actuator. The actuator calibrates the min. and max. positions automatically according to the set limits.

The actuator can be controlled from this point on by using a 0...10 VDC control signal. (0 VDC=min.position, 10 VDC = max. position).

It is also possible to remove the HAQ-unit from the frame by opening two knurled-head screws (4) for the adjustment.

Adjustment of Halton Velocity Control

The Halton Velocity Control unit is adjusted by manually turning the sections of the unit. The HVC units have three different positions: 1 = throttle position, 2 = normal position, and 3 = boost position.

Specification

The multiservice beam is an active chilled beam for exposed installation with bi-directional air supply. The front panel shall be openable and detachable from either side without the use of any special tools.

The chilled beam shall have a infill extension to cover the connection duct and pipe installations between wall and beam and also between two beams (optional).

The chilled beam shall have an air flow adjustment damper.

The front panel and side panels shall be made of pre-painted galvanised steel plate. All visible parts shall be white RAL 9010, 20% gloss.

The primary air flow rate shall be adjustable over a wide range via a separate supply air unit of the chilled beam. Adjustment of the air flow rate shall not have any effect on induced air flow rate through the coil. The induced room air flow rate shall be manually adjustable to three positions without influencing the primary air supply flow rate.

Supply air flow rate shall be manually adjustable using an airflow damper, or equipped with an actuator for demand-based control of air flow (optional). Control of supply air flow rate shall not have any effect on coil cooling and heating capacities. The adjustable-air-flow-rate beam shall have only one duct connection. The appearance of the chilled beams with constant air flow and adjustable air flow rate shall be the same.

The active chilled beam shall be equipped with 0 – 2 recessed integrated flush mounted luminaires with (option: dimmable) electronic ballasts. Luminaires shall be of T5 type (high efficiency) and equipped with reflectors suitable for the office environment. Same lights shall be used as indirect and direct lighting.

The chilled beam shall be equipped with a cable tray.

All pipes shall be manufactured from copper, connection pipes with a wall thickness of 0.9-1.0 mm. The cooling heat exchanger shall consist of six 15-mm pipes connected in series. The fins of the heat exchanger shall be manufactured from aluminium. Heating shall be incorporated within the heat exchanger via two 10-mm pipes connected in series. All joints shall be factory pressure-tested.

The maximum operating pressure of pipework shall be 1.0 MPa. Each active chilled beam shall be protected by a removable plastic coating and individually packed in a plastic bag. Duct connection and pipe ends shall be sealed for transit. Each chilled beam shall be identifiable by a serial number printed on a label attached to the active chilled beam.

Order code

CBQ/S-E-L-C

S = Direction of supply patterns & nozzle type

- A Bi-directional / Nozzle 1
- B Bi-directional / Nozzle 2
- C Bi-directional / Nozzle 3
- D Bi-directional / Nozzle 4

E = Duct connection/Duct size/Damper

- S2N Straight / 125 /Without damper
- S2D Straight / 125 /With damper
- F2N 1. module / 125/Without damper
- F2D 1. module / 125 /With damper
- T2N Conn. both ends / 125 / Without damper
- T2D Conn. both ends / 125 / With damper
- E2N End module/125/ Without damper
- E2D End module/125/ With damper

L = Total length

1200,+100,...,4000

C = Effective length (Cooling coil length)

800,+100,...,3600

Other options and Accessories

TC = Cooling / Heating functions (Coil type)

- C Cooling
- H Cooling and Heating
- G Cooling with connection in series
- I Cooling and Heating with connection in series

CO = Colour

- W White
- X Special colour

AQ = Air quality control

- A Manual
- B Motorised
- R Retrofit possibility

LV = Type of direct light fitting

- N Without light
- 2C 2 x light 28 W Halton
- 2D 2 x light 35 W Halton

- 2E 2 x light 21 W Halton
- 2M 2 x light 14 W Halton
- 4C 4 x light 28 W Halton
- 4D 4 x light 35 W Halton
- 4E 4 x light 21 W Halton
- 4M 4 x light 14 W Halton

LC = Lighting control

- C1 On/Off
- C2 0...10V, dimmable
- C3 DALI, dimmable

EM = Emergency light fitting

- N No
- L1 Left first
- L2 Left second
- R1 Right first
- R2 Right second

CV = Control valves & actuators

- N No
- A1 Adjust. kv value, factory mounted, no actuator
- A3 Adjust. kv value, factory mounted, 24V act.
- A5 Adjust. kv value, factory mounted, 240V act.
- A7 Constant-flow-mounted
- A9 Constant-flow-mounted, 24V act.
- A11 Constant-flow-mounted, 230-V act.

TX = Temperature sensor

- N No
- T1 NTC 10k
- T2 NTC 20k
- T3 NTC 1,8k
- T4 Ni 1000
- T5 Ni 1000LG

AC = Accessories

- OX Multisensor for lighting control
- CX CO₂ sensor (0...10V)
- WX Condense detector (1V free relay contact)
- LS Speaker

Sub-products

- DCB Duct cover

Code Example

CBQ/A-S2N-2000-1600 TC=C,CO=W,AQ=R,
LV=2M,LC=C1,EM=N,CV=N,TX=N