

Operators Manual for **Capture Ray**[®] (UV)

Manual provides
Operation, Maintenance and Service Instructions

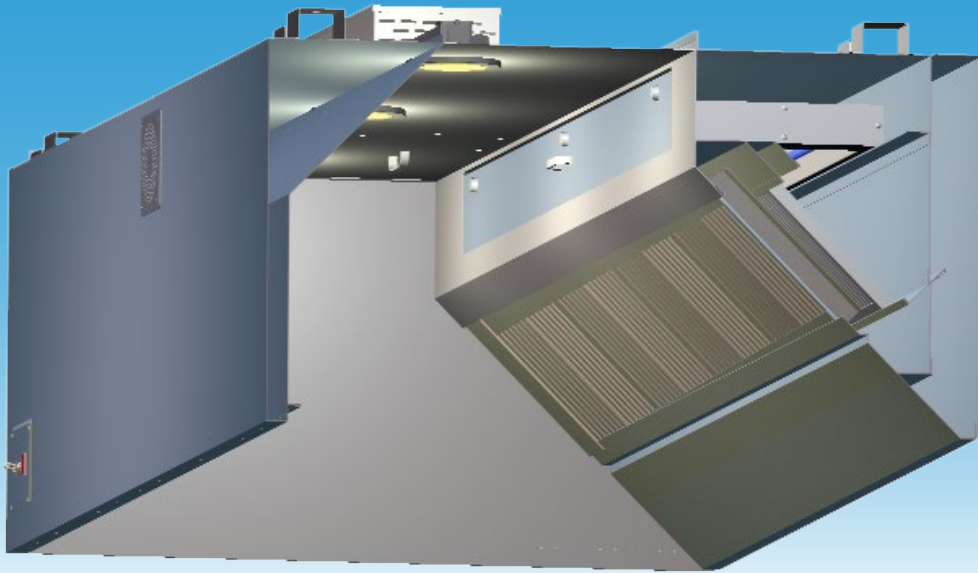

Capture Ray[®] Hoods with UV Technology
KVE-UV, KVC-UV, KVL-UV, KVW-UV

GENERAL DESCRIPTION

Halton's Capture Ray® technology provides solutions for a variety of commercial food service ventilation applications over virtually any cooking process. Based on Halton's patented highly efficiency Capture Jet® solution and advanced mechanical KSA filter technology, the Capture Ray® (UV) feature keeps the plenum and duct virtually grease free and mitigates the cooking odor and emissions. The integrated Capture Ray® Ultraviolet cassette(s) are positioned in the exhaust plenum of the hood behind the mechanical grease filters. The grease vapor and effluents that are not collected by these high-efficiency mechanical filters pass over the UV lamps. This causes a chemical reaction within the grease molecules that destroys the grease and converts it into carbon dioxide and water vapor. The chemical action carries over into the exhaust duct and helps keep the duct and exhaust fan clean. The UV system is built into the hood with complete controls and safety features which prevent exposure to the UV light.

The hood is complete with a control panel indicating the total hours of operation, safety alarms, security on, and exhaust fan failure. There are two sizes of UV cassettes: one short, which is (234W) 38" long, one long, which is (390W) 66" long. These cassettes are matched to the overall length of the hood in various combinations to provide maximum grease destroying capability for the hood. The UV control panel is suitable for a single phase power supply and is constructed to meet the UL listed protection standard.

The cassette access plate includes a hinged door for ease of maintenance and replacement of the UV bulbs. The cassettes are mounted on a rack and are easily removed by disconnecting the electrical connectors on the cassettes end. The UV cassette access door comes equipped with safety switches. If the door is not secured in the closed position, the system will not operate. The control panel is connected to the electrical control box of the fan via a relay which detects any exhaust fan failures. The UV system will not operate if the exhaust fan does not work

To achieve the optimum performance from your hood system (s) please use the following guidelines provided within the pages of this Installation, Operation, and Maintenance Manual.

In addition to this information our offices or local representatives are available at any time to provide additional technical support for products, applications, installation, commissioning or in any aspect that you may have.

RECOMMENDATION

Upon receipt of the Halton hood (s), inspect unit (s) immediately for any shipping damage and notify carrier immediately if damage is found. Halton will not accept responsibility for any shipping damage. All systems are thoroughly inspected before leaving our factories; however Halton will assist in filing a claim if needed.

GENERAL INSTALLATION

It is the responsibility of the installing contractor to see that the system installation is completed in accordance with the project plans and specifications and that it meets all specific requirements of local code officials. The local authority having jurisdiction could over rule some of the installation details written in this manual. The installation shall be in accordance with NFPA-96. All electrical systems shall be installed following local and national codes.

The owner and/or operator should be instructed in the proper operation, care and maintenance of the system.

If questions or complications should arise during the installation of the Halton hood (s) that cannot be solved using the instructions provided please contact the Halton office at 1-800-442-5866, or (1-800-4-HALTON).

Note: There are no instructions contained within this manual for installation or maintenance of fan packages.

**See appropriate manufacturers manual for detailed instructions.

EXHAUST AIRFLOWS

Please see submittal drawings or contact the manufacturer for each hood's exhaust air flow rates. Halton's applications department determines the optimum exhaust rate for effective capture & containment of cooking effluent. These exhaust airflows are included in the job submittal drawings for each hood and are customized for the specific kitchen appliance arrangement and environment.

INSTALLATION INSTRUCTIONS

1. Inspect the crating carefully. If there are signs of damage, call the freight carrier before uncrating the units. Carefully uncrate the units. Check all local codes prior to installation; special requirements may be necessary depending on local building material construction.

** Important note ** Do not leave unit (s) exposed to extreme temperatures for an extended period of time, this may cause the protective PVC coating around the unit (s) to become very difficult to remove.

2. Position the hood near the actual installation site. In case of multiple hoods, check the engineered set of drawings for locations. Pay close attention to collar sizes and fire protection layouts, matching the hood systems to the correct location shown on the drawings provided.

**Check item numbers on crates / hoods vs. drawing item numbers.

3. Once the hood is carefully removed from the shipping crate and set in position, the unit is now ready for installation. If Halton Company has supplied a backsplash assembly, then the splash assembly should be installed first, for installation procedures see pg. 3.
4. Hang the hood using ½" threaded rods by attaching the rods to the hood through the hanger brackets that are welded to the top of the hood. Use of turnbuckles with the threaded rod sections will make final adjustment easier. Standard hanging height for canopy hoods ranges from 78" min. to 84" max. from the finished floor to the lower edge of the front of the hood (per local codes having jurisdiction). **Noted in installation instructions - see pg. 3.

Note:

Allow 100lbs (45kg) per linear foot hanging weight.

Do not lift exhaust hoods from their end panels. Lift from four corners.

All exhaust hoods and control panels are fitted together and factory tested prior to shipping for alignment and operation.

5. Duct connections must meet NFPA 96 requirements and applicable local codes. Size of connection is indicated on exhaust hood drawing. Connection is to be made after exhaust hood is hung.
6. Electrical circuits should be connected according to the standard switch panel wiring diagram. UV hoods have additional wiring requirements to connect the control panel to the hoods, as well as connections between multiple hoods operated from the same control panel. The following electrical service requirements are field installed:
 - A 120 volt, 15 amp uninterrupted supply to the control panel.
 - A 120 volt circuit from the control panel to the exhaust fan starter coil or relay.
 - A 120 volt circuit from the control panel to the make up air fan starter coil or relay.
 - A separate 120 volt, 15 amp supply to the light fixture junction box(es) on top of each hood.Note: The selector switch on the control panel controls the exhaust fan operation. Please see job specific wiring connection information in the job submittal drawings and an additional wiring diagram is included in the electrical control box shipped with the job. Additional copies may be obtained from the factory if this wiring diagram is missing or lost. Please be prepared to provide the job order number (found on the sales invoice), job name and address or submittal drawing series number when contacting the factory for this or other job specific documents.
7. Grease filters and grease cups must be installed in place before start-up.
8. Halton hood come standard with high output, long lasting LED light fixtures. Optionally incandescent or recessed fluorescent fixtures may be ordered. Please note only install 100 watt maximum light bulbs in incandescent light fixtures. Fluorescent bulbs should be type T8, 36" or 48" long in fluorescent fixtures. **Note: Halton does not provide bulbs for incandescent or fluorescent lights.
9. If Closure Panels are supplied by Halton see pg. 9 for details on the installation.
10. For multiple hoods end to end, or back to back see pg. 8 for Installation of Splice Strips and U-Channels.
11. Protect the hood from damage under normal job site conditions, until all work is complete and system is ready to be put into operation.

BACKSPLASH INSTALLATION

1" Insulated Backsplash Assembly

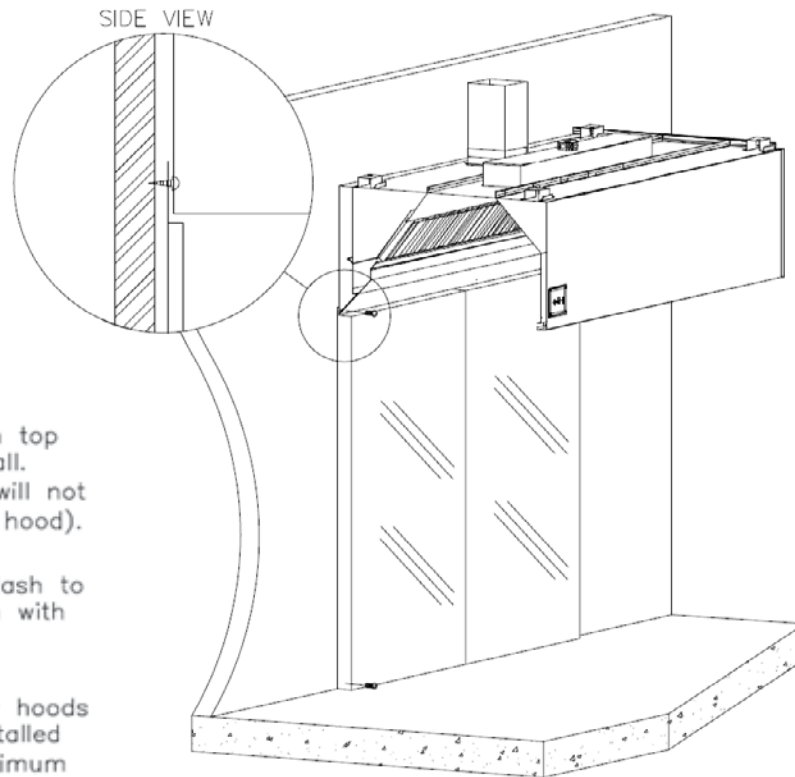

Screw through top flange into wall.
(Screw head will not interfere with hood).

Screw backsplash to wall or attach with adhesive.

Halton canopy hoods should be installed from 78" minimum above finished floor to 84" maximum above the finished floor.

Flat Sheet Backsplash Assembly

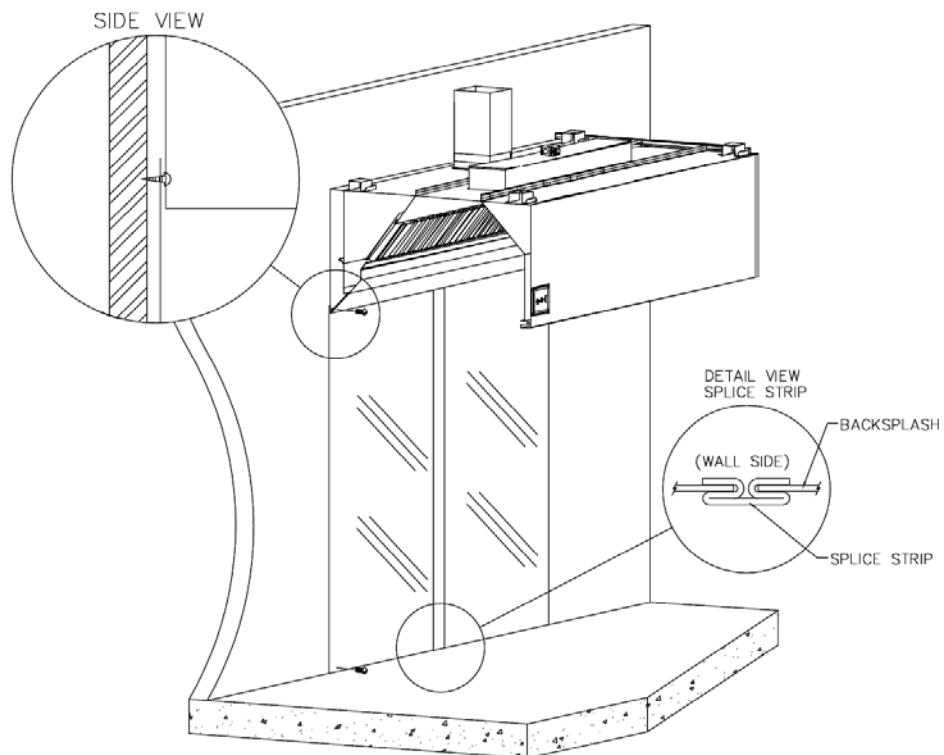

HOOD INSTALLATION DETAILS

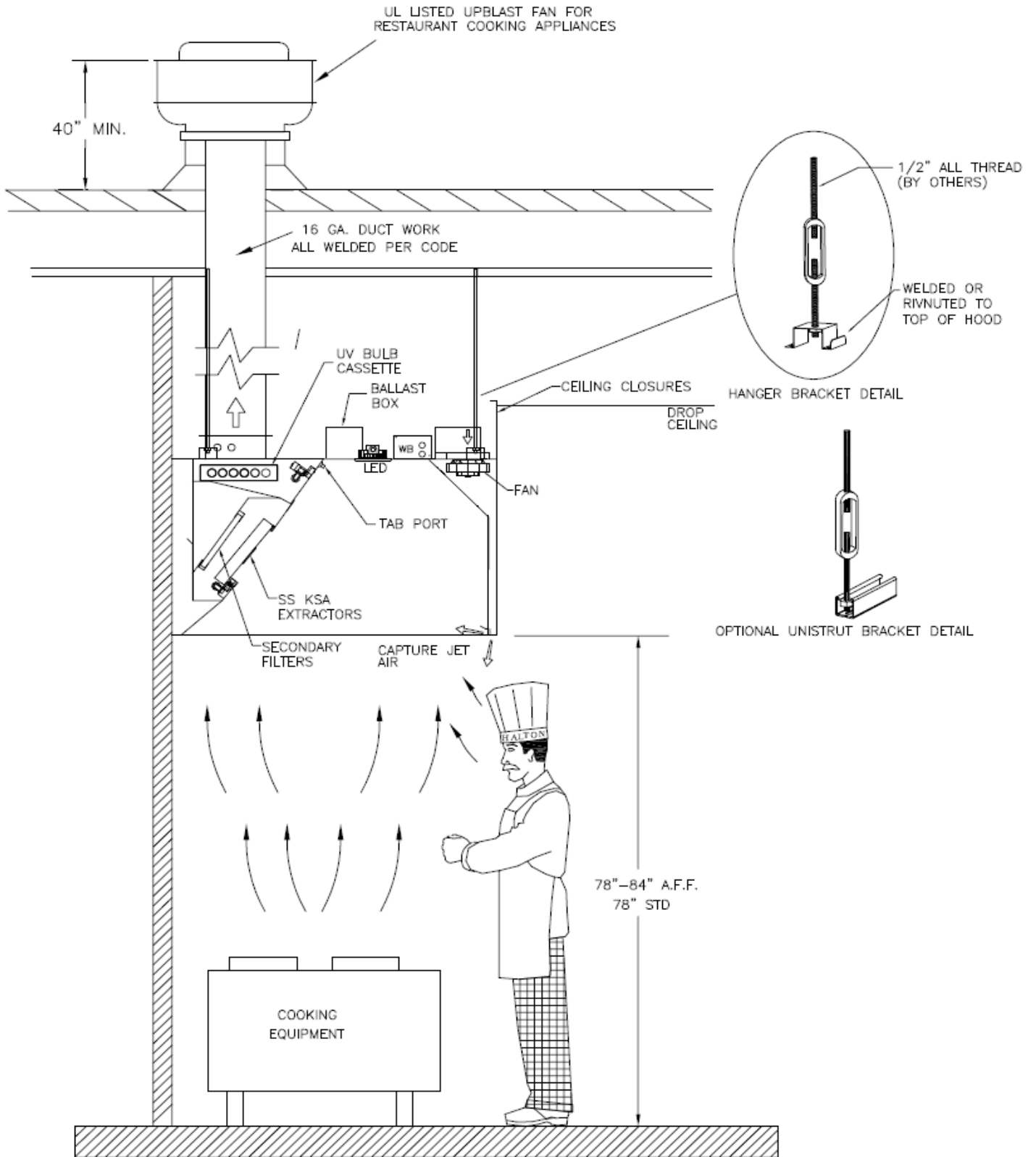

EXHAUST DUCT CONNECTION DETAILS

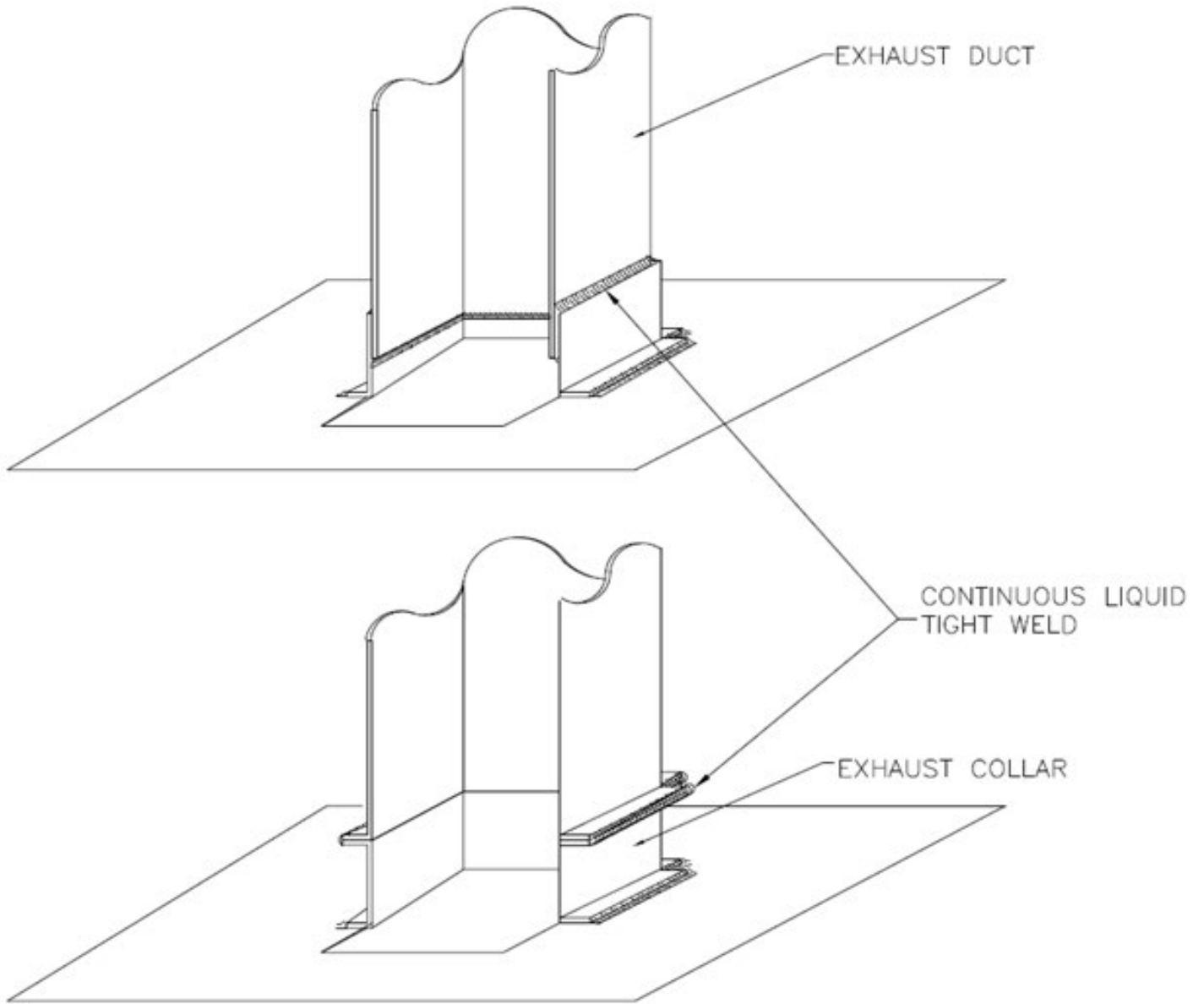

SPLICE STRIP/U-CHANNEL ASSEMBLIES

Hoods end to end

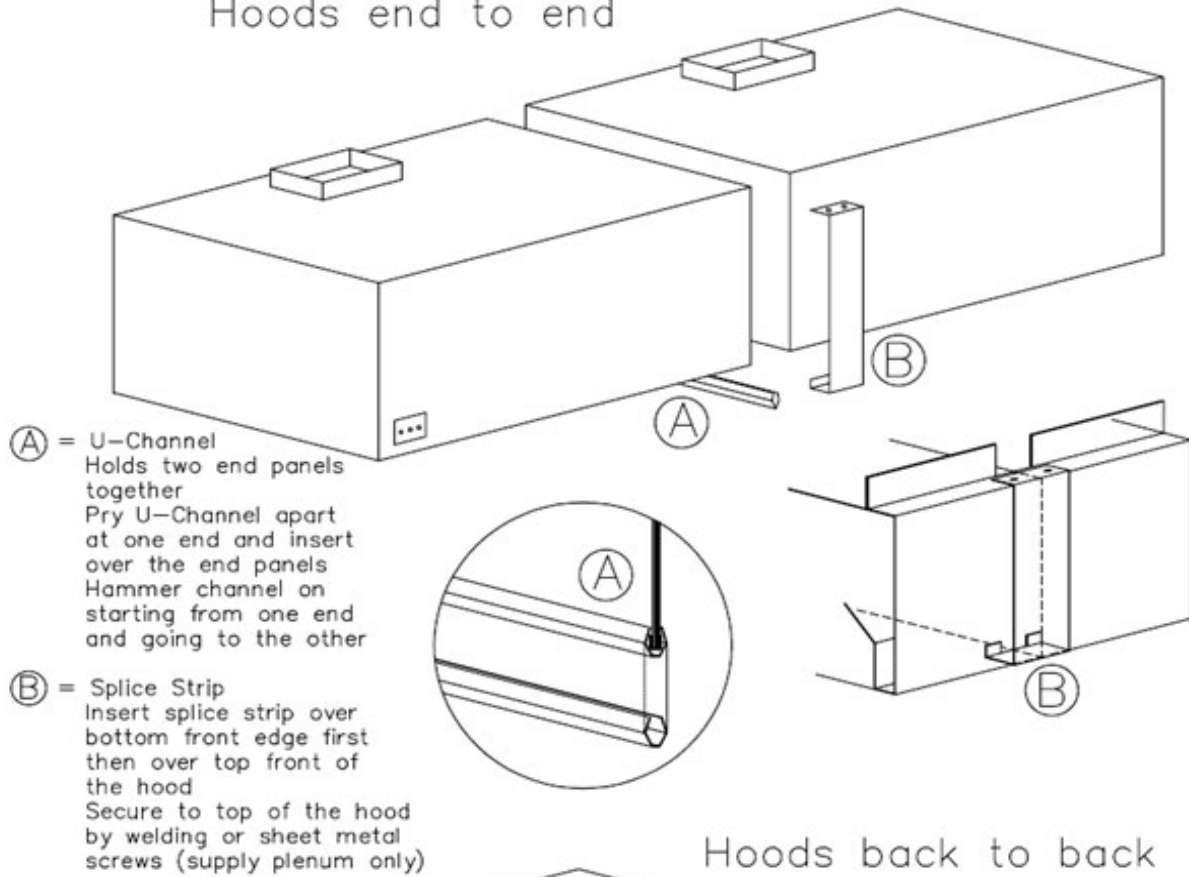

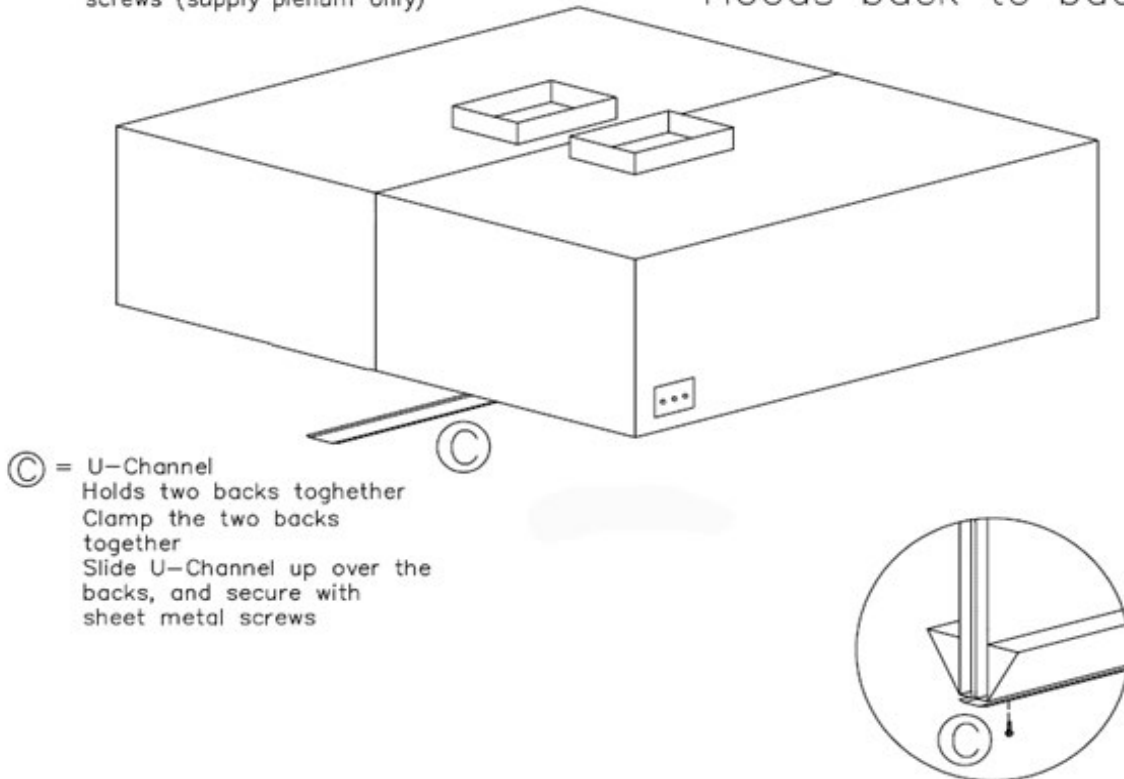

Hoods back to back

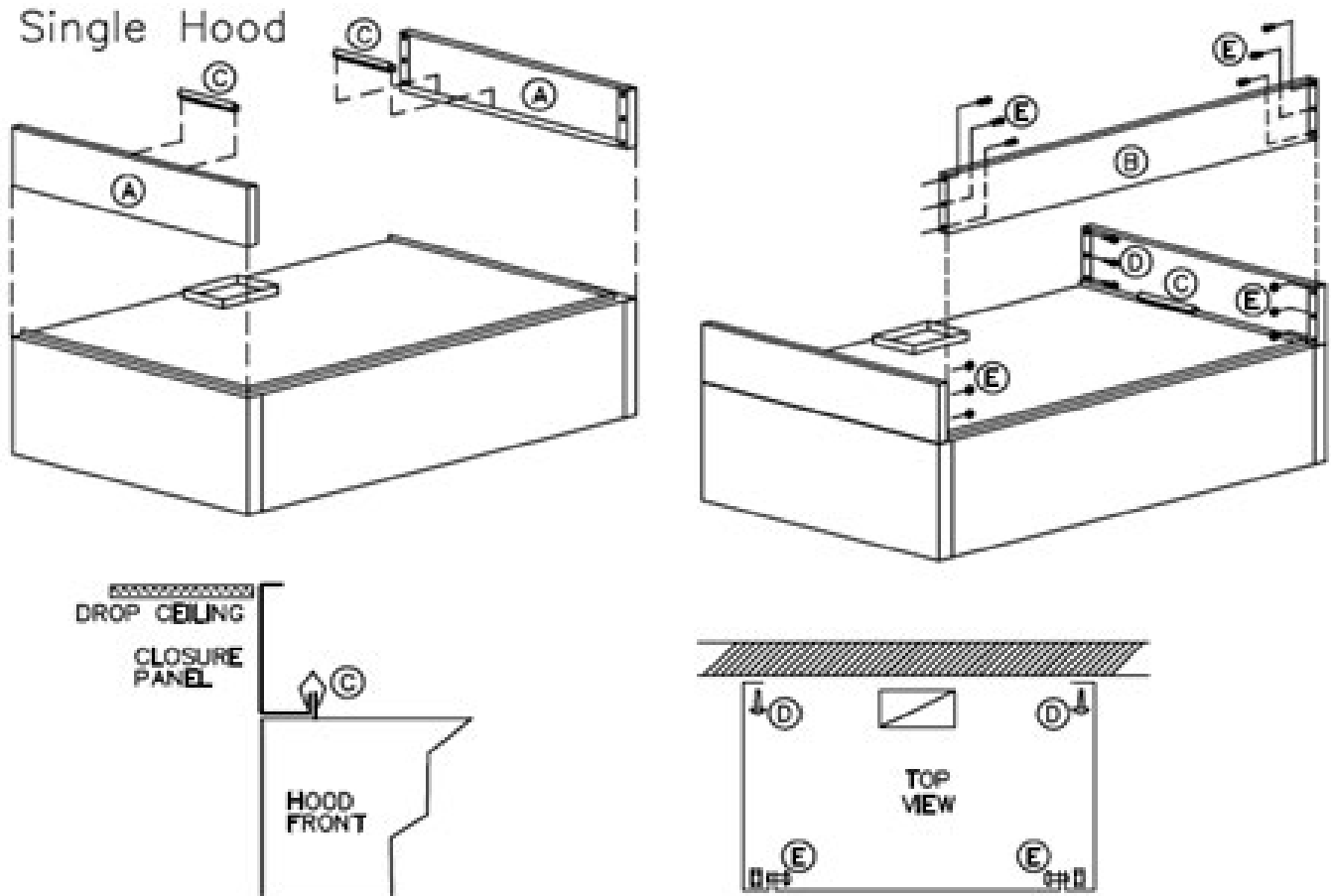

CLOSURE PANEL ASSEMBLY - SINGLE HOOD



- | | | |
|-----|---|---------------------------------------|
| (C) |  | Closure Clips (By Halton) |
| (D) |  | Wall Attachment Hardware (By Others) |
| (E) |  | Panel Connection Hardware (By Others) |

1. Panels "A" are placed on the top of the hood on the outside perimeter of the hood at each end of the hood group.
2. Align the clips "C" over vertical flanges and hammer clips down over flanges.
3. Attach panels "A" to rear wall with hardware "D".
4. Attach panel(s) "B" to panels "A" with hardware "E" .

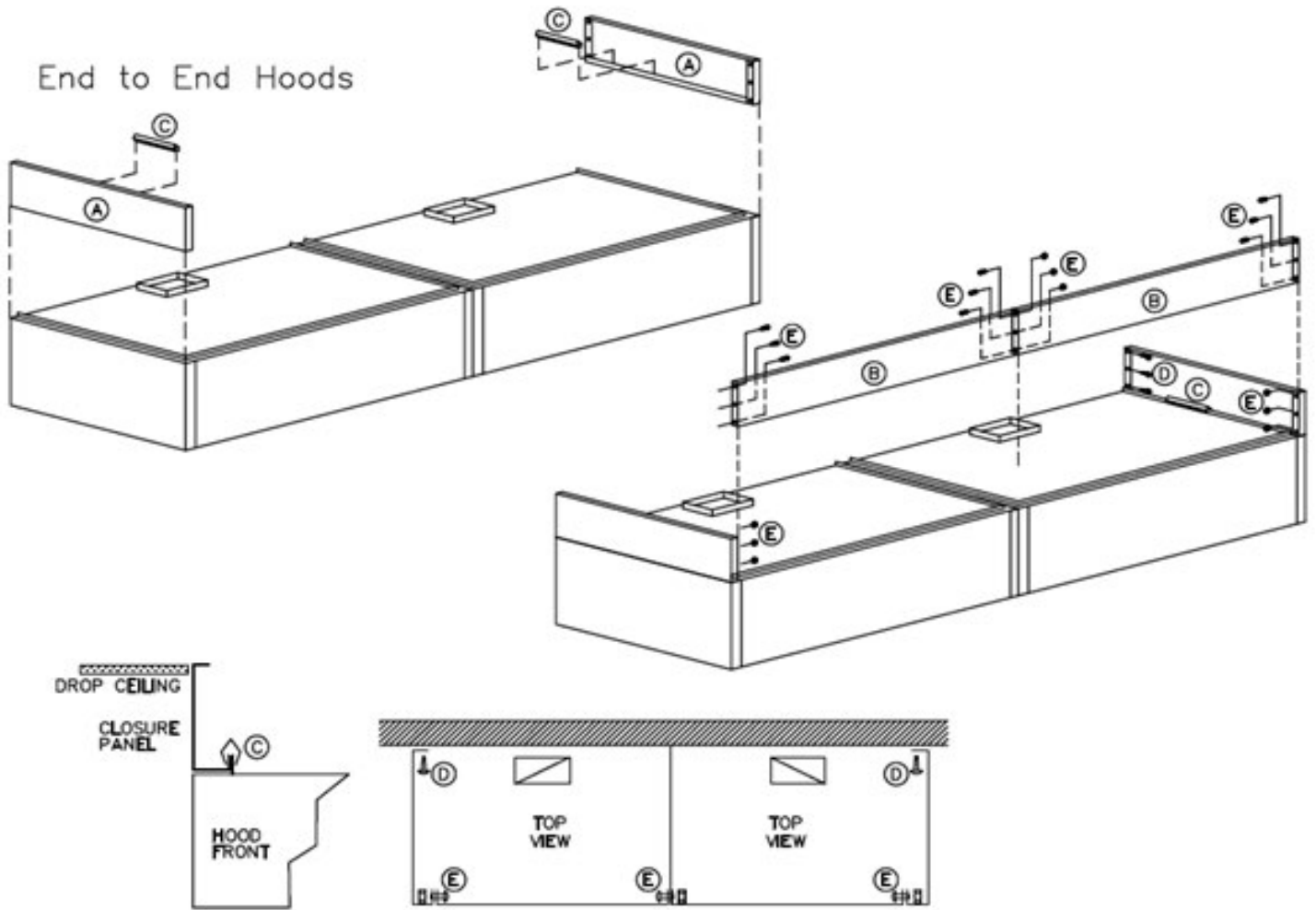

CLOSURE PANEL ASSEMBLY - END TO END HOODS

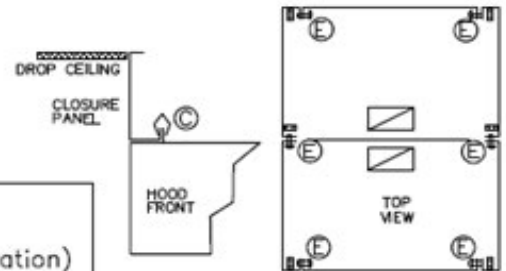
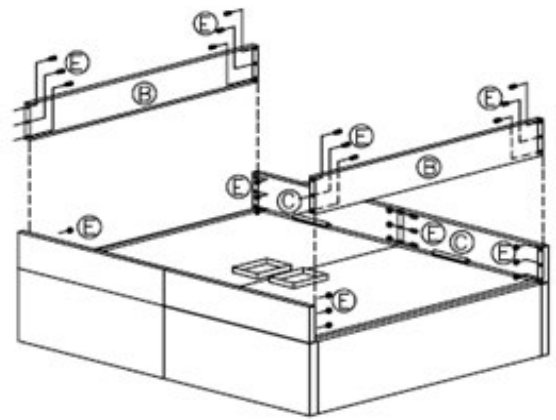
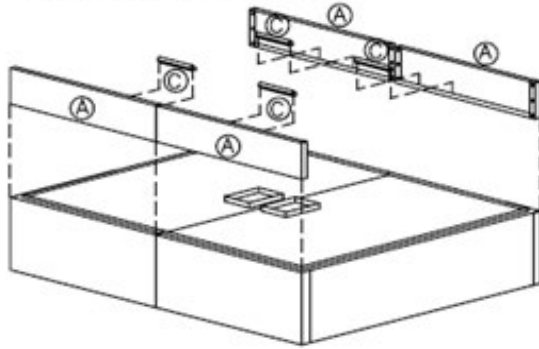

CLOSURE PANEL ASSEMBLY - BACK TO BACK HOODS

Back to Back Hoods



-  Closure Clips (By Halton)
-  Wall Attachment Hardware (Not Used in this Configuration)
-  Panel Connection Hardware (By Others)

1. Panels "A" are placed on the top of the hood on the outside perimeter of the hood at each end of the hood group.
2. Align the clips "C" over vertical flanges and hammer clips down over flanges.
3. Attach panels front "A" panels to rear "A" panels with hardware "E".
4. Attach panels "B" to panels "A" with hardware "E".

CLOSURE PANEL ASSEMBLY - END TO END BACK TO BACK HOODS

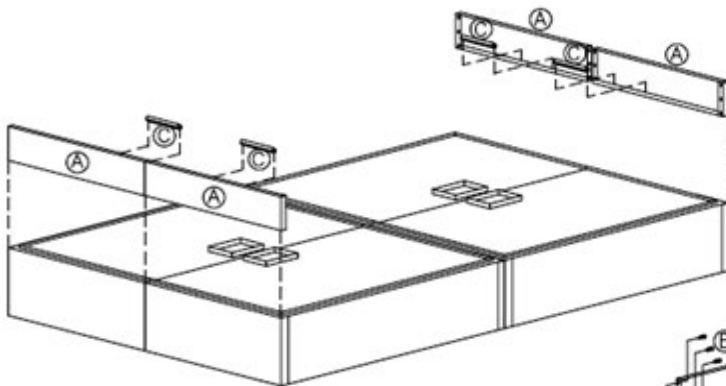

End to End and Back to Back Hoods

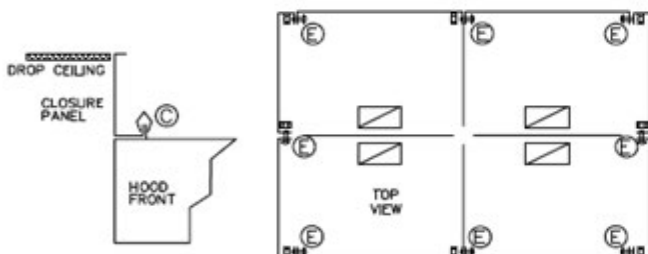
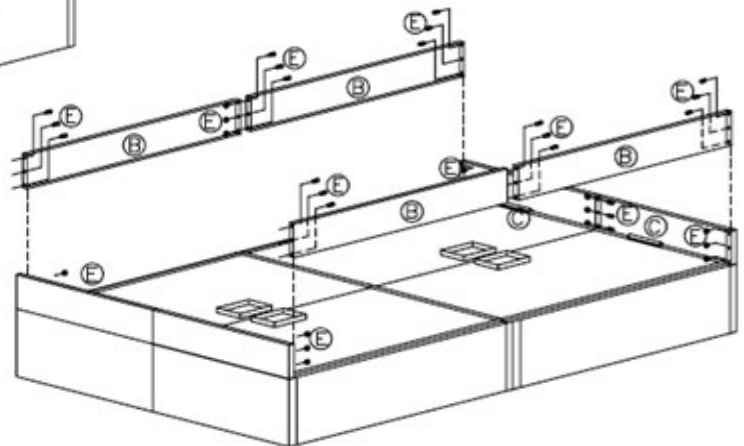

CLOSURE PANEL ASSEMBLY - HOODS WITH KDS RISERS

Hoods with KDS Risers

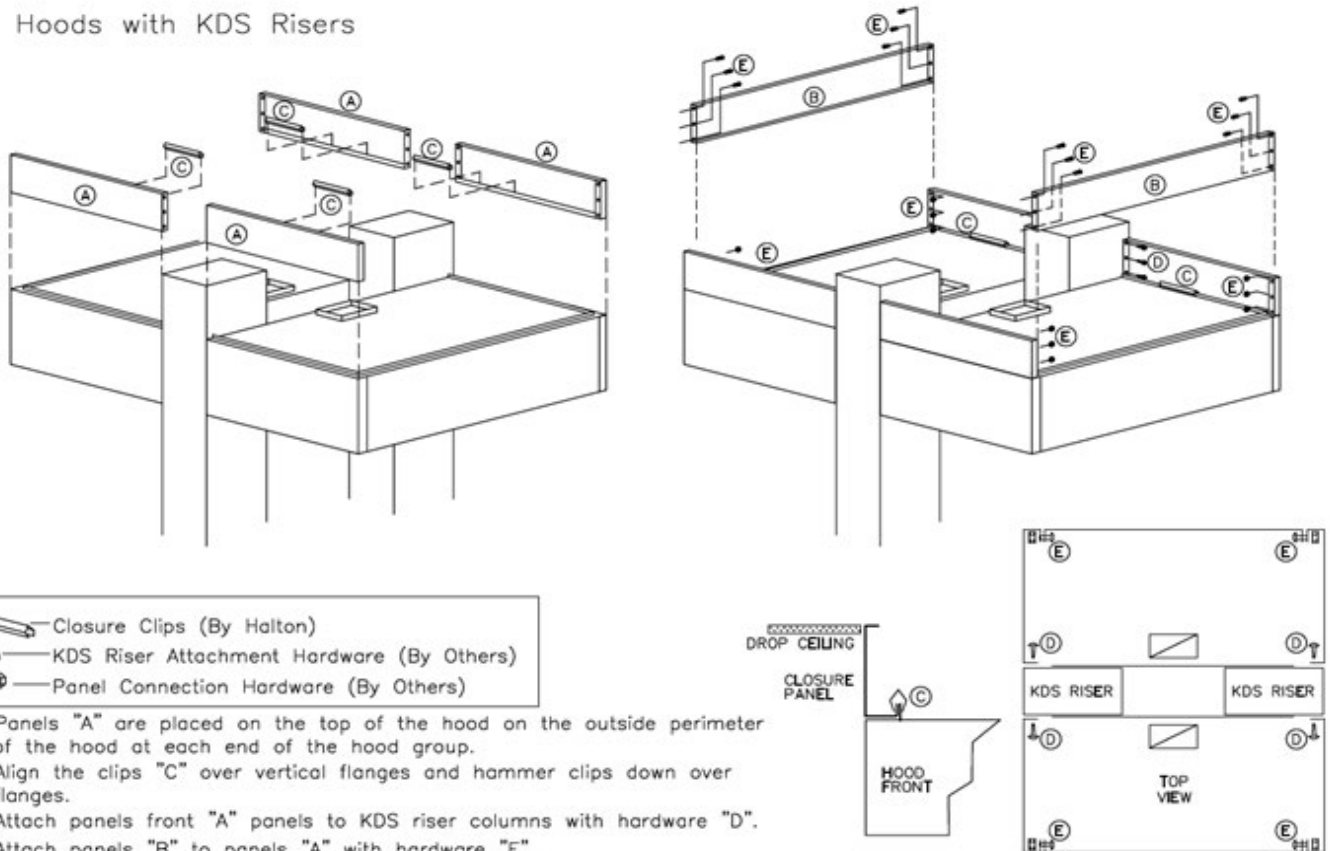

-  Closure Clips (By Halton)
-  KDS Riser Attachment Hardware (By Others)
-  Panel Connection Hardware (By Others)

1. Panels "A" are placed on the top of the hood on the outside perimeter of the hood at each end of the hood group.
2. Align the clips "C" over vertical flanges and hammer clips down over flanges.
3. Attach panels front "A" panels to KDS riser columns with hardware "D".
4. Attach panels "B" to panels "A" with hardware "E" .

OPERATION OF SYSTEM

After installation is complete it will be necessary to check and balance the airflows through each hood. The static pressure for each hood is listed in the hood information table on the job specific submittal drawings. The specific exhaust static pressure for each hood should be referenced for the airflow balance for that hood. The exhaust air being drawn through the grease filters creates a negative static pressure behind the filters in the exhaust plenum. This negative static pressure can be measured and has a direct relationship to the total exhaust airflow measured in CFM (Cubic Feet per Minute). Halton Capture Jet® hoods are calibrated based on the model of hood and the number of grease filters the hood has. A static pressure curve is provided with each hood which allows the air balancer to easily set up the exhaust fan to draw the correct exhaust CFM through the hood based on measuring the static pressure of the exhaust plenum. On the Capture Jet® line of hoods, Halton supplies T.A.B. (Testing And Balancing) ports for measuring the negative static pressure drop through the filters and also the positive Capture Jet® plenum pressure. These ports are located on the inside of the capture portion of the canopy on the exhaust and Capture Jet® plenums. The T.A.B. port for measuring exhaust static pressure is on the exhaust plenum side of the hood, near the top inside panel and is found near one of the corners above the grease filters. The T.A.B. port for measuring the Capture Jet® static pressure is found in the inner front of the hood, near the top inside panel and near one of the corners of the inner face. There is a black plastic cap on each of the brass T.A.B. port fittings to keep them clean. The cap should be removed for taking the static pressure measurements and then replaced when the measurements are completed. The exhaust static pressure is measured

using the negative connection on the manometer, leaving the positive port of the manometer open to atmosphere. The Capture Jet[®] static pressure is measured using the positive connection on the manometer, leaving the negative port of the manometer open to atmosphere. Adjustment to the static pressure of the exhaust plenum is made by adjusting the speed of the exhaust fan. Adjustment to the Capture Jet[®] fan is made inside the inner front of the hood at the Capture Jet[®] speed controller. See procedure below if Capture Jet[®] fan adjustment is necessary.

****It is very important that the fan for the Capture Jet[®] air be balanced according to specifications.**

See the job specific information for required airflows. The Capture Jet[®] fan is adjusted at the factory for proper airflow. Check the static pressure of the Capture Jet[®] plenum and adjust the Capture Jet[®] fan speed only if the pressure reading is different than the T.A.B. port pressure specified on the job specific submittal drawings (measured reading outside of plus or minus 0.05" w.c.). Adjustments to the Capture Jet[®] fan can be made with the speed controller supplied with the fan. This speed controller will be mounted inside the Capture Jet[®] plenum, the adjustment control knob can be accessed by removing the chrome button cover in the center of the Capture Jet[®] fan access cover. The speed controller is adjusted using a small flathead screwdriver, turning the control clockwise to decrease the speed of the Capture Jet[®] fan, and turning the control counterclockwise to increase the speed. Very small movements of the control will result in appreciable static pressure changes to the Capture Jet plenum. Monitor the manometer connected to the T.A.B. port of the Capture Jet[®] plenum as adjustments are made. After each adjustment allow the pressure to stabilize before adjusting further.

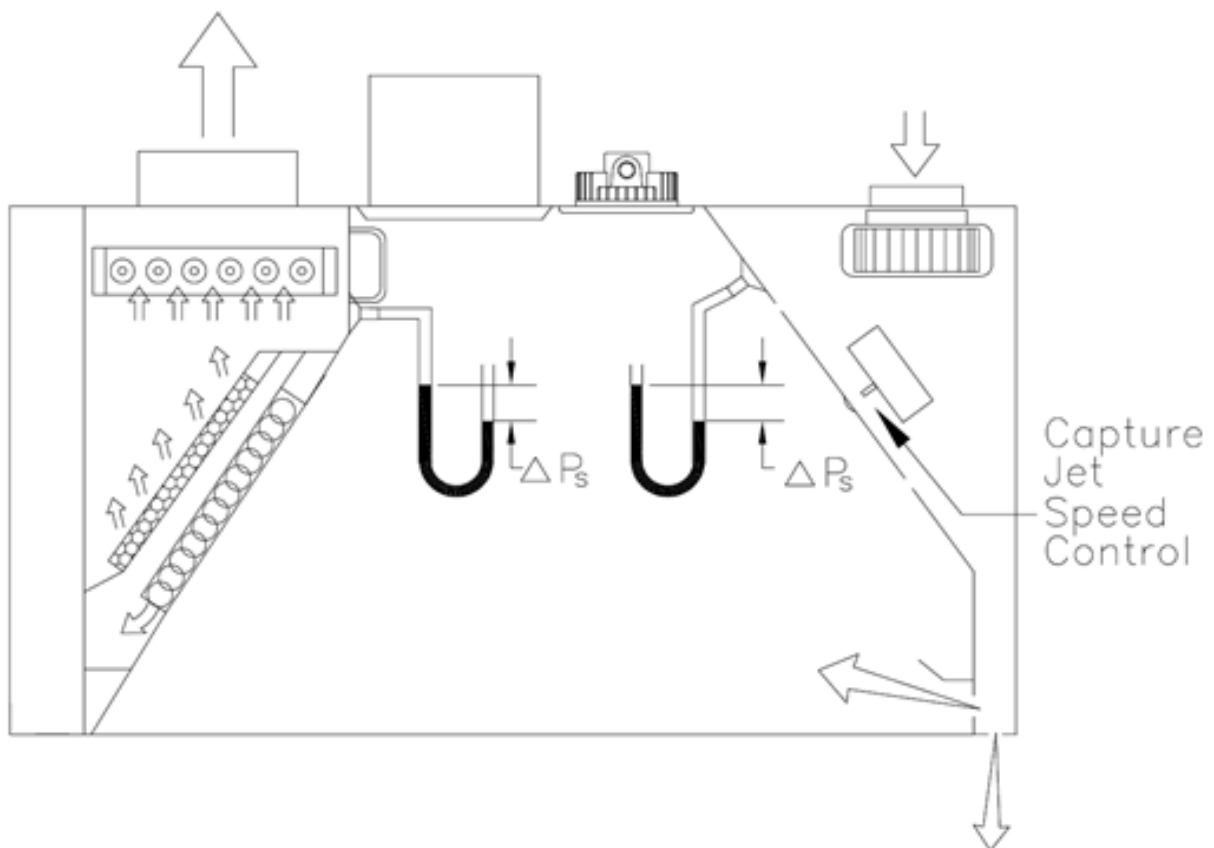

Capture Jet® T.A.B. Port Readings	
Hood Model	Design T.A.B. (inches WC)
KVE/KVC	0.25
KVW	0.25
KVR	0.25
KVL	0.29

Exhaust T.A.B. Readings vs. Airflow

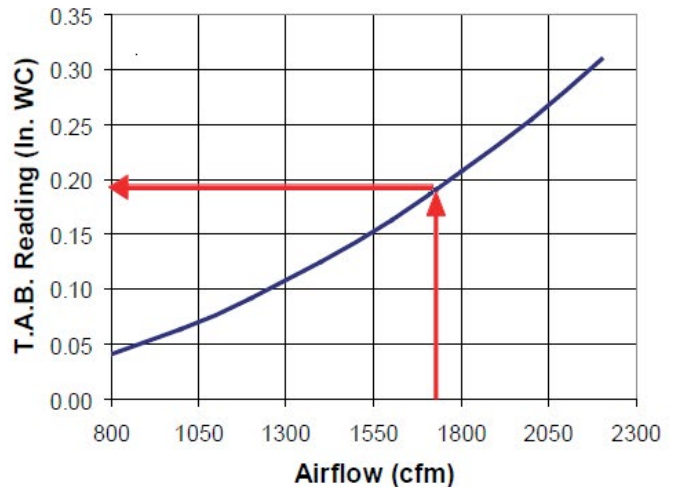

The Capture Jet® and exhaust air flows are easily and accurately determined by measuring the pressure difference from the T.A.B. (Testing and Balancing) ports mounted in each plenum. The corresponding air flows can be read from the diagram provided.

To properly measure T.A.B. port readings use a magnehelic gauge or digital manometer and for exhaust plenum reading hookup hose from negative connection on instrument to T.A.B. Port on exhaust plenum. Leave positive connection on instrument open to atmosphere.

Measured Pressure

This example shows how to determine the correct T.A.B. port reading for the exhaust hoods.

In this example, a design airflow of 1700 cfm is selected from the Airflow axis, and a vertical line is drawn up to the T.A.B. pressure curve for this hood.

A horizontal line is then drawn for the T.A.B. pressure curve to the T.A.B. reading axis on the left-hand side of the chart and the corresponding pressure is read off the chart as 0.19 inches of Water Column.

- Halton Capture Jet® Hoods are equipped with efficient model KSA grease filters. The KSA grease filters must be removed and cleaned by qualified employees of the restaurant owner or by a cleaning agency. Halton UV system grease filters must be removed and replaced in a certain order. Please see detailed instructions on pg. 16 that describe the removal and replacement process.
- Exhaust airflows should be properly set for each exhaust hood, and supply or make up air should be brought into the space to balance the exhaust air leaving the space through the hoods. Kitchen exhaust hoods will not perform according to design if supply or make up air is inadequate. After the exhaust and supply airflows have been properly balanced, a final inspection should be made to ensure proper system operation.

UV with Light Sensor

Halton's Capture Ray® hoods are equipped with a Light Sensor. The Light Sensor monitors the output of the UV lamps in a UV cassette. When the system is started the sensor compares the present light output of the UV lamps to the output of the lamps when they were new. If the output of the UV lamps in the cassette(s) is between 100% and 80% of the output when new the system

continues to operate normally. If the output has dropped below 80% of new, and the lamps have more than 500 hours since they were last cleaned a "Clean UV" alarm appears on the control panel. This means it is time to clean the lamps in the UV cassettes found in the grease plenum of the hood. If the output has dropped below 80% of new and the lamps have less than 500 hours since they were last cleaned a "Replace UV" alarm appears on the control panel. This means the lamps are producing a reduced amount of UV light and should be replaced. Contact your local Authorized Service Agent for replacement of the lamps.

CROSS SECTION OF A CAPTURE RAY® HOOD

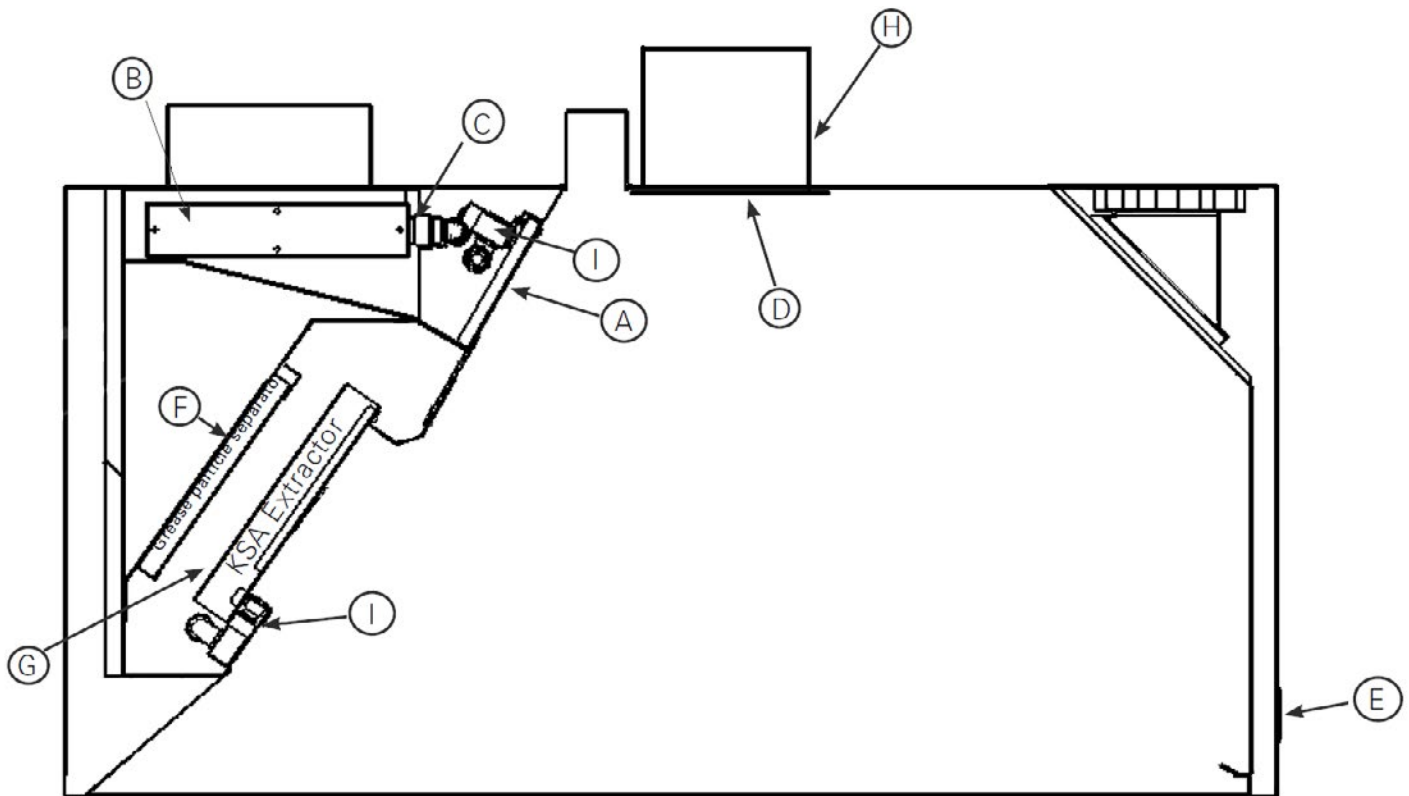

Item	Description
A	Cassette Access Panel - for easy access and removal of UV cassette(s)
B	UV Cassette - contains multiple UV lamps (Handle with care)
C	Amphenol Connector - Military spec fitting for electrical connection in plenum
D	Ballast Box Access Panel - for access to components
E	Lamp status indicator - shows status of each UV lamp operation.
F	Grease Particle Separator (GPS) filter
G	Primary Extractor - A multi-cyclone KSA extractor
H	Ballast Box- located on the top of the hood for control of the UV cassette(s)
I	Safety Switches

Halton highly recommends that the facility enter into a formal annual maintenance contract with the local Authorized Service Agent. Contact the factory directly if you would like the name and phone number of the local ASA.

1. Clean the hood canopy inside and out as needed with mild soap and water. Never use harsh or abrasive cleaners on Stainless Steel or Painted surfaces, making sure to wipe clean all interior and exterior surfaces of the hood including the light fixtures.

**** Never clean the hood canopy when any of the surfaces are hot.**

2. The KSA stainless steel filters and the GPS filters need to be cleaned regularly. The frequency of cleaning is load dependent. The cleaner the filters the better the UVC system will perform. Filters can be soaked in a degreaser overnight and rinsed in the morning before being replaced or they can be run through a commercial dish machine. Please see instructions below that describe the removal of the KSA primary filter and cleaning process. After removing the KSA filters remove the GPS filters. Lift the GPS filter upwards until the bottom of the filter clears its track, swing the bottom out forward and pull the filter downwards to clear the upper track. Replace the GPS filter by reversing the above instruction.

Primary Filter Removal Instructions

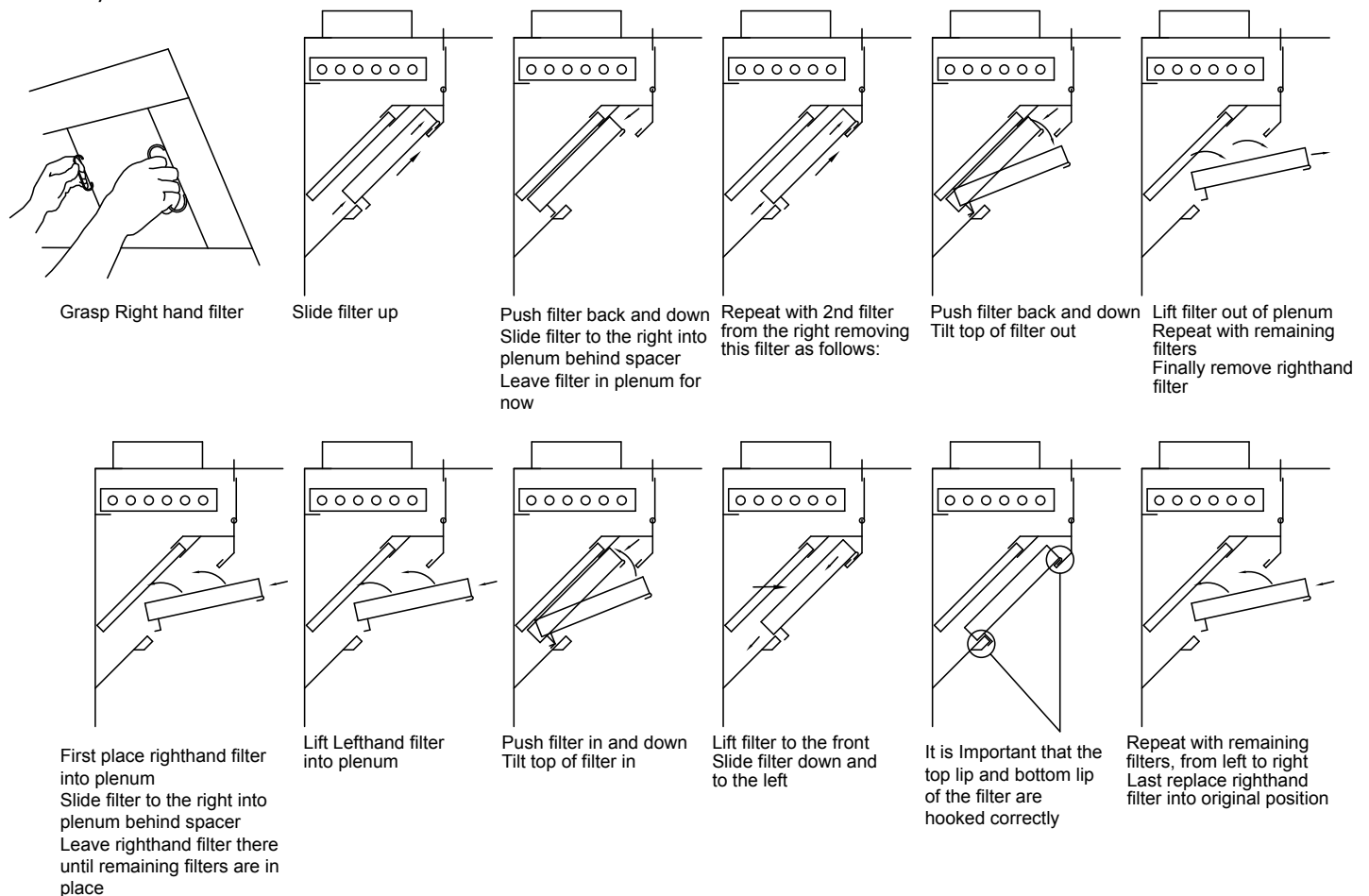

KSA, GPS & UV BULBS & CASSETTE CLEANING INSTRUCTIONS:

As previously stated, Halton highly recommends that the facility enter into a formal annual maintenance contract with the local Authorized Service Agent. Contact the factory directly if you would like the name and phone number of the local ASA.

The cleaning process of the UVC bulbs does require time and the bulbs must be handled with great care as they can easily be broken.

The UVC Bulbs must be cleaned regularly in order to allow for the system to operate at peak efficiency. Dirty or greasy UV bulbs will not allow for the grease particulate and grease vapors to be converted into organic compounds. As a result, excessive grease will accumulate in the duct work and more frequent duct cleaning costs will occur.

In order to clean the UVC bulbs one will need to shut off the electrical power to the system at the control panel. Once the appliance cook top has cooled the cassettes which hold the UVC bulbs will need to be removed. The first step involves removing the KSA & GPS filters. Then open the UV access panel door by turning the black knobs to the open position. The door is hinged and will open towards the operator and down.



Next disconnect the supply wiring from the cassette. The connector is accessed through the filter plenum where the KSA and GPS filters have been removed. Disconnect the supply wiring by turning the connector 1/3 of a turn counter clockwise and then pull it straight out.



Once the supply wiring has been disconnected the cassette should be removed by sliding it forward and out of the cassette tray. Handle the UV cassette only by the steel framework. Never pull the cassette or carry the cassette by the glass bulbs. Be sure when placing the cassette on any surface that there is no object that will strike or put pressure on the glass bulbs. Place the cassette with UVC bulbs on a flat stable surface. Gently wipe off each bulb with a standard glass cleaner and dry cloth until the grease particulate and film has been removed. Do not put lateral pressure on the bulbs (don't push the bulbs sideways), only push gently down the length of the bulb. Do not immerse the UV Cassette!

Once the bulbs have been cleaned the cassette can be slid back into the tray. Reconnect the supply wiring by aligning the small pin on the cassette side of the connector with the slot in the wiring side of the connector. The location of the small pin is marked with a blue paint dot on the mounting base of the connector that is on the cassette.

Close the access door and turn the black knobs until the door is securely closed.

NOTE:

The frequency of cleaning the UVC bulbs will be reduced when a routine cleaning schedule for the KSA and GPS filters is diligently followed. The conversion of the grease particulate and grease vapors into an organic compound is dependent upon the efficiency of the UVC bulb.

UV Bulb Status Indicator Panel:

A UV bulb status indicator panel is located on the front of each UV equipped hood. There will be one status panel for each cassette the hood has, for a maximum of two panels. The LED indicator lights show that the corresponding UV bulb for that cassette is operating normally. If a bulb burns out or stops working the corresponding LED indicator light will go out also. There is a decal on the end of the cassette underneath the end cap which corresponds to the label on the indicator panel (L1, L2, L3, etc.). This gives feedback for the Authorized Service Technician about which bulb must be replaced. The bulbs must only be replaced by factory trained technicians. This is not a user serviceable item. The rubber grommet must also be replaced at the time the bulb is replaced. The cassette is still 100% efficient with only 5 of the 6 lamps operating. This gives the operator some extra time to arrange for the inoperative bulb to be replaced.



INSTRUCTION FOR RE-LAMPING

1. With the cassette removed from the hood, remove the screws from the end caps #3.
2. Unplug the lamps from lamp sockets #4.
3. Carefully slide each bulb through the lamp grommets.
4. Remove the lamp grommets #2 and replace with new grommets.
5. Carefully slide the new lamps through new grommets and re-connect lamp sockets #4.
6. Re-install end caps #3 and attach with screws.

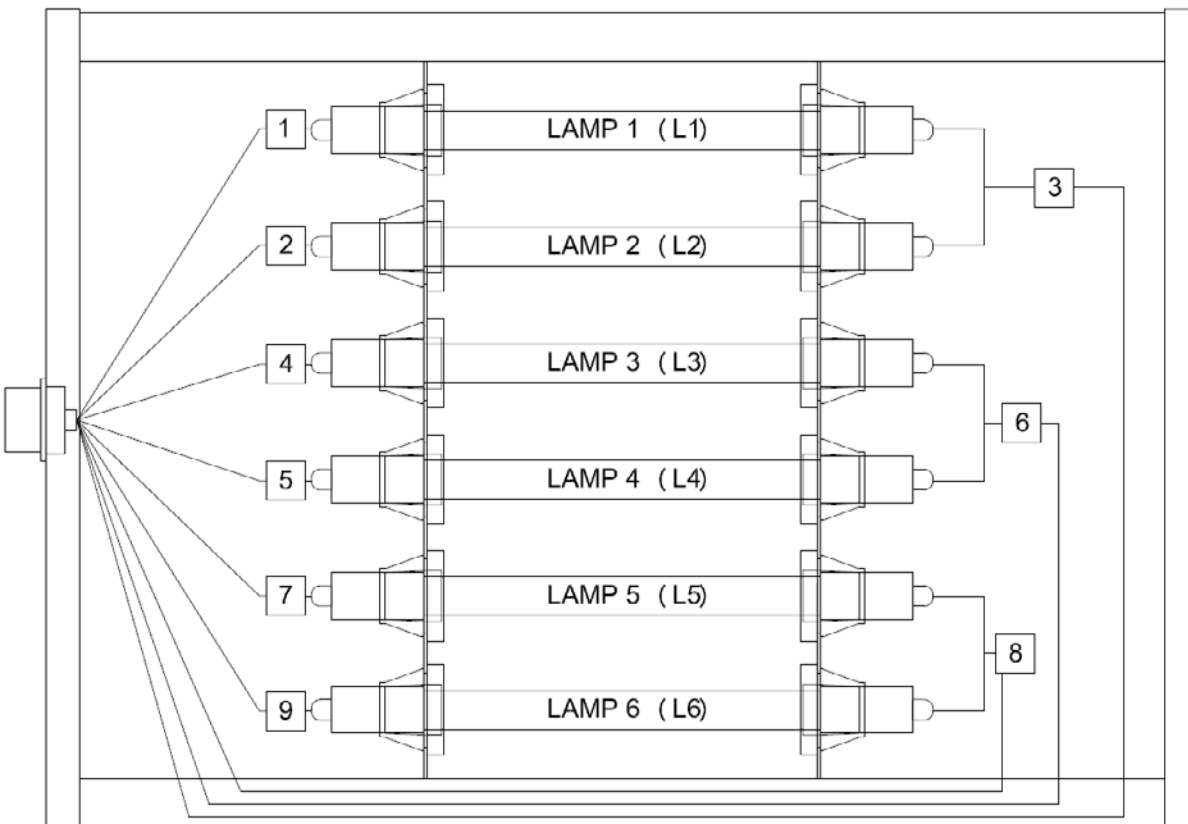
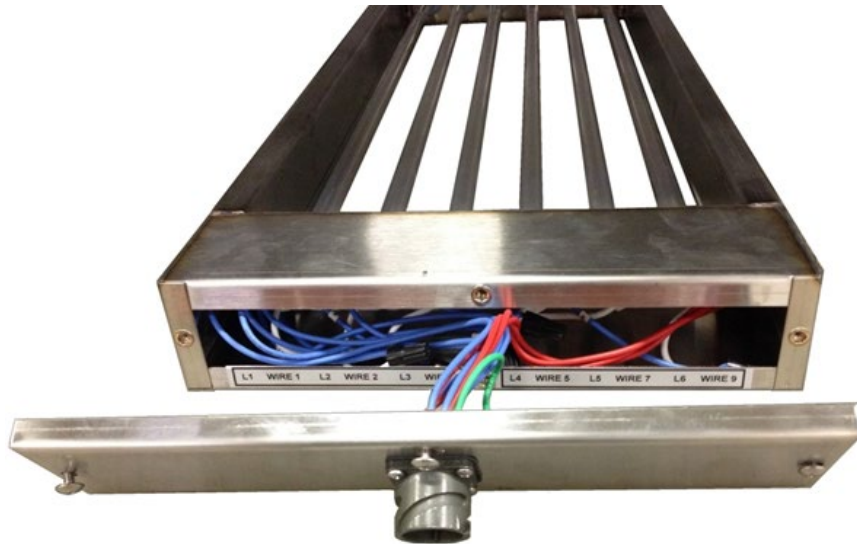

TYPICAL WIRING OF LIGHTS AND CAPTURE JET FAN

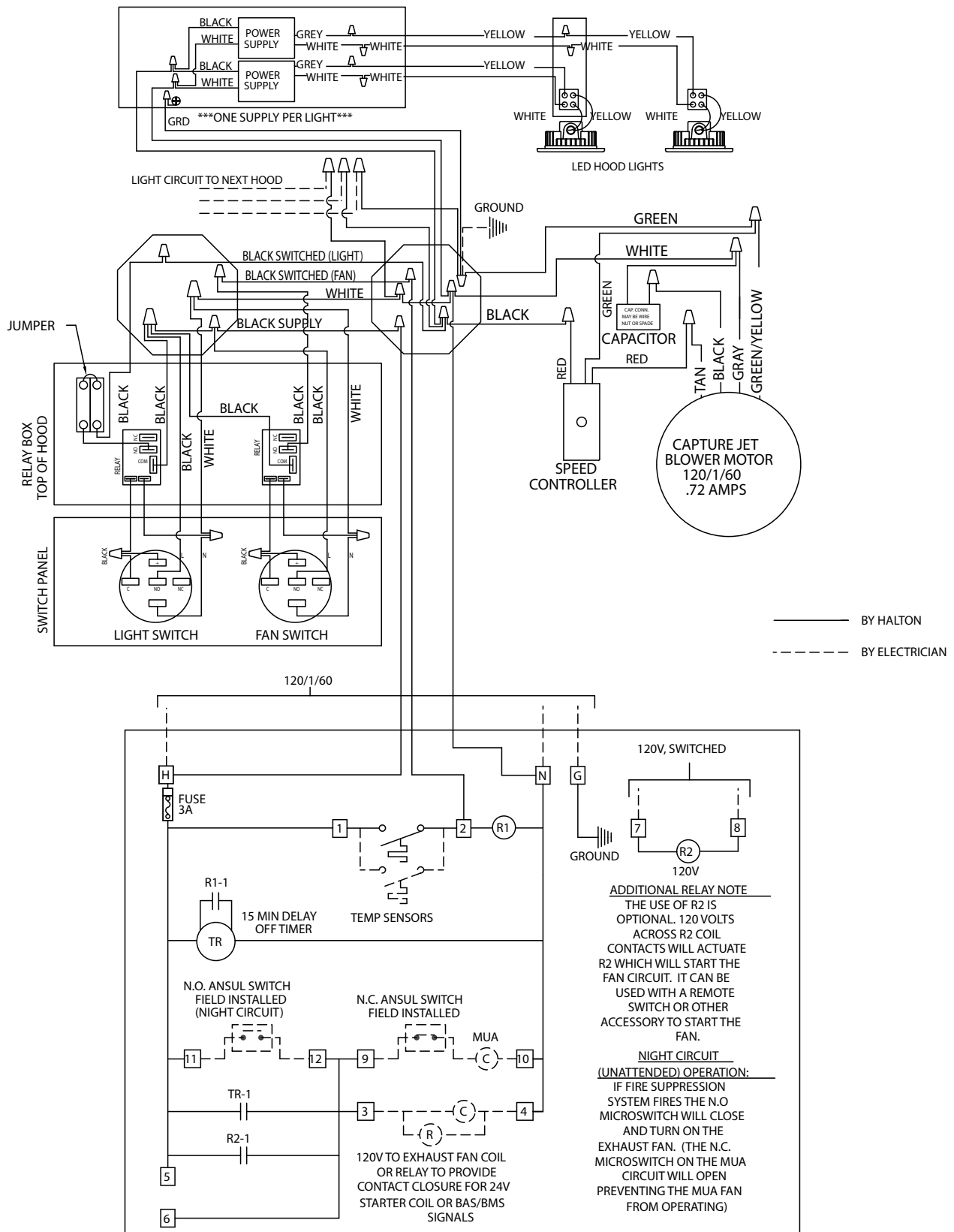

TIMER PANEL

TEMP SENSOR OPERATION:

WHEN ENOUGH HEAT (95°F) TO ACTIVATE SENSOR IS PRESENT, EX FAN AND MUA FAN WILL START AND WILL REMAIN ON FOR 15 MIN AFTER HEAT SENSOR DEACTIVATES. FAN SWITCH CAN OVERRIDE HEAT SENSOR "ON" FUNCTION AT ANY TIME. FANS WILL REMAIN ON FOR 15 MIN AFTER EXHAUST FAN SWITCH IS TURNED "OFF".

UV CONTROL PANEL

- 120V, 60Hz supply voltage
- All field wiring 24VAC
- Controls UV functions, exhaust fan and make up fan
- One control panel per exhaust fan required regardless of number of UV hoods
- Either local or remote ON/OFF operation
- Interlock with fire system
- Touch screen user friendly interface
- Total number of UV hours operation monitored as well as hours since last UV tubes cleaning
- Alarms
 - Low airflow
 - Filter removed
 - UV door open
 - UV failure
 - Clean UV
 - UV end of life
 - Fire
- Compact size 12" x 18" x 5"
- Optional light switch

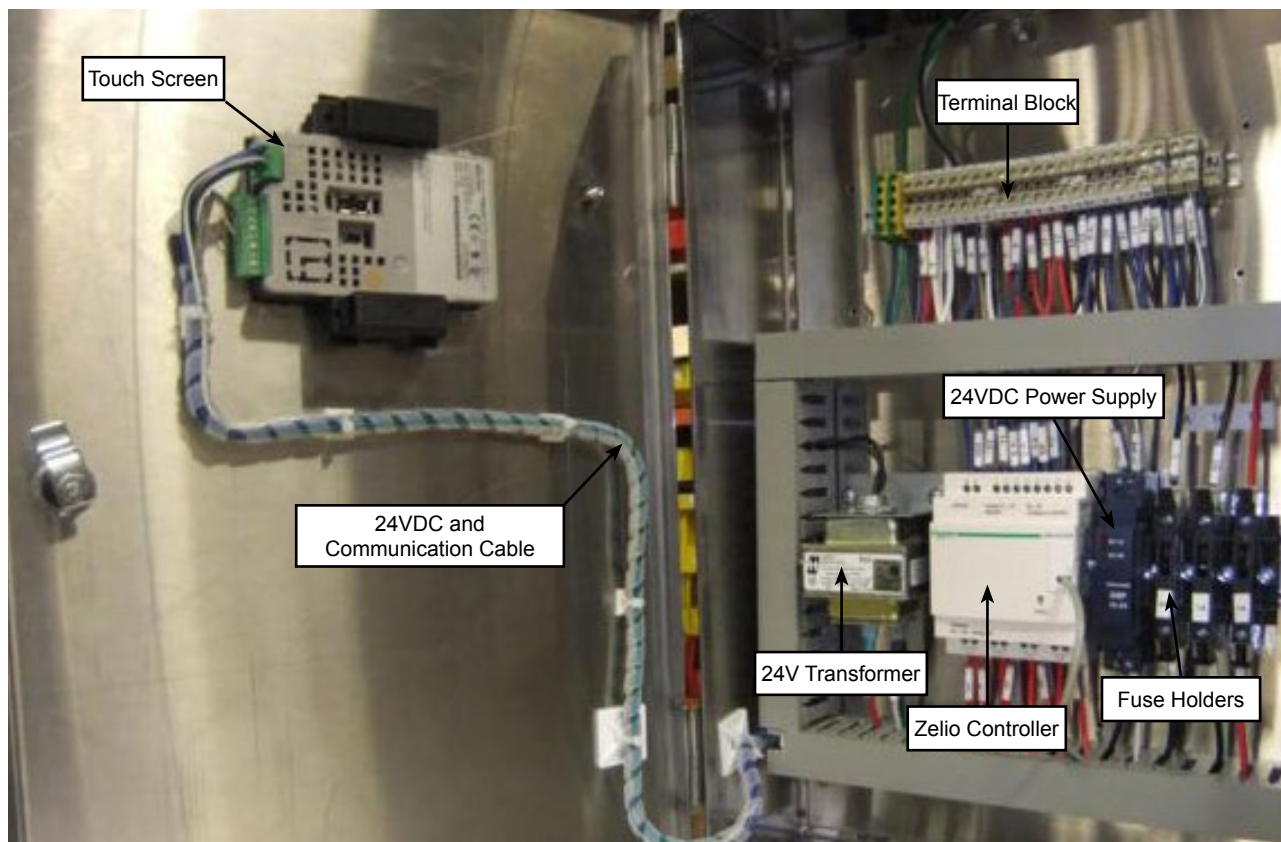

UV CONTROL PANEL - SEQUENCE OF OPERATION

System ON

- UV On
- Exhaust fan On
- Makeup fan On

System OFF

- UV Off
- Exhaust fan runs for 30 sec to exhaust ozone from the system and turns Off
- Makeup fan On

Fire

- Exhaust fan will continue to run or it will start (even if system is off).
(Exhaust fan can be turned off in fire mode if required by local fire code).
- Make up fan will turn off or remain off.
- UV is turned off or remains off.

Main Screen

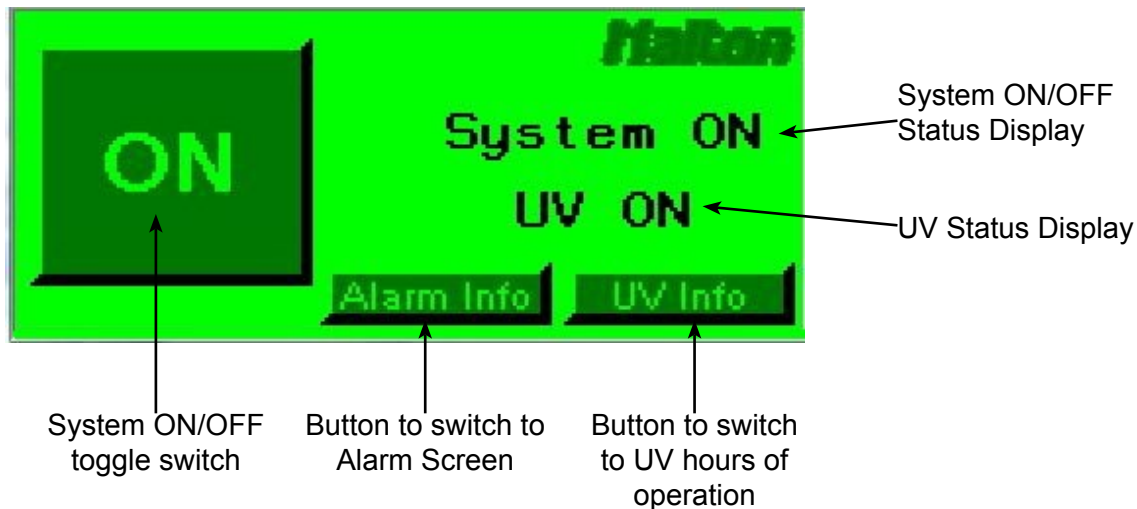

To turn the system ON, touch the ON/OFF toggle switch on a Main screen.

Exhaust and make up fan are turned on, UV is ON

Note: System can be configured to be turned On/Off remotely with dry, open contacts connected to terminals 1 and 4. In this case the On/Off push button on a touch screen will not be available.

UV Info Screen

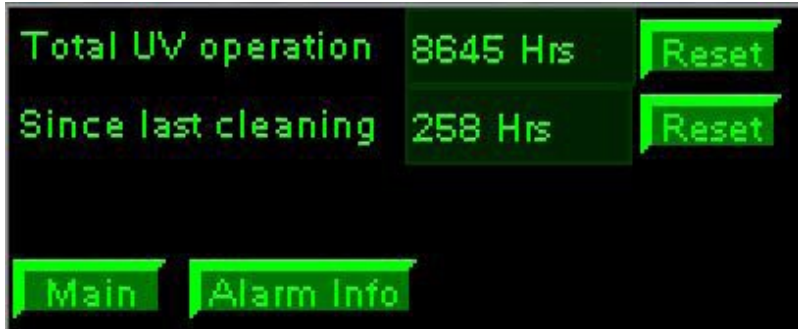

Press the “UV Info” button on Main screen to navigate to UV Info screen to read the total number of hours of UV operation and the number of hours since last cleaning.

It also allows resetting those statistics.

The number of hours since last cleaning has to be reset after each UV lamp cleaning. If UV lamps are replaced with new ones, both statistics, the total number of hours and since last cleaning have to be reset.

To reset any of those statistics, press corresponding “Reset” button. This operation is password protected so a password data entry window will pop up.



Touch “Name” or “Password” field, to enter values. Keypad will popup to let enter data. After done, press “Ent”



This screen will pop up with your Name and Password entered. Press the "login" button to be logged in.



New screen shows that you are logged in as User: 0000



Exit the security screen by pressing the Exit button. You will be taken back to the "UV Info" screen already logged in as User 0000

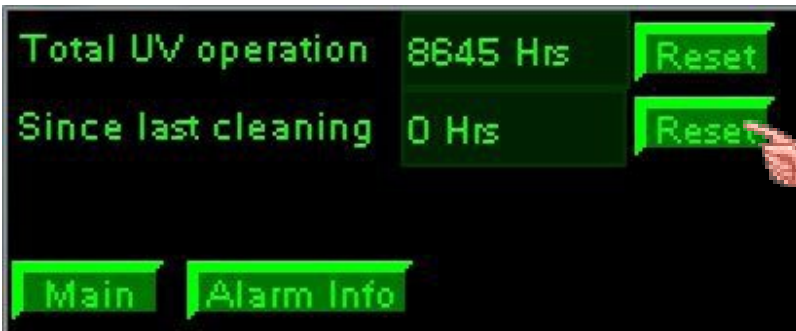

To reset any of those statistics press corresponding "Reset" button. Number of hours since last cleaning has been reset to 0 Press "Main" to switch to the main screen.

Alarm Info Screen

If during normal operation any alarm is activated, the screen automatically switches to "Alarm info" screen and the back light turns red. Active alarms is displayed as well as System status (fans) and UV status.

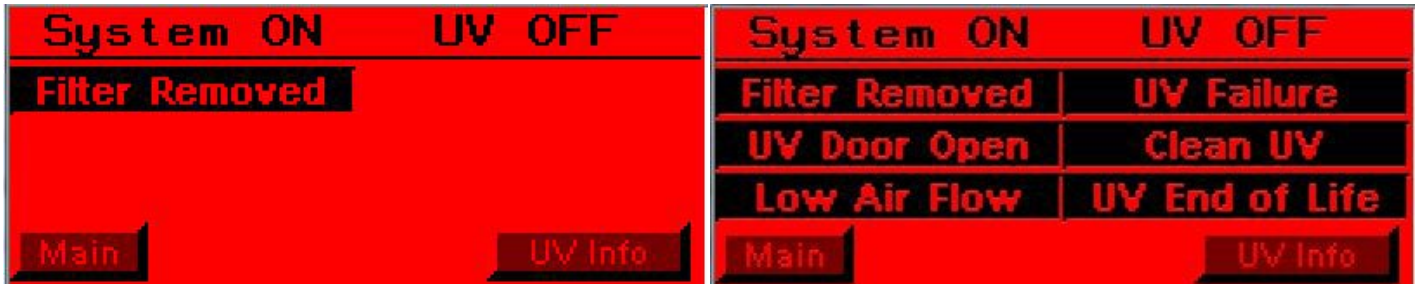

If all alarms are cleared, the screen switches automatically to "Main" and back lights turns green. You can navigate manually from the "Alarm info" screen back to "Main" screen, however the back light remains red for as long as any alarm is active.



Fire Screen



Fire alarm has its own dedicated "Fire" alarm screen. If during operation the Fire input is activated, the screen automatically switches to "FIRE" alarm screen. All other alarms even if active are hidden for as long as fire condition exists.

ALARMS

“Low airflow” – Pressure switch from each hood is connected to terminals 1 and 15. Alarm is activated on switch closure. There is a 60 sec. delay to activate this alarm. It allows the pressure to built-up in a system after exhaust fan starts as well as to prevent false alarms on pressure fluctuation. UV in affected hood only is turned off.

“UV failure” – there is a 30 sec. delay to allow all UV tubes to ignite. LED indicators on face of a hood show which lamps are Off. UV failure switch is located on each UV ballast board and is connected to terminals 5 and 1. UV stays on when alarm active.

“Clean UV” and **“UV End of Life”** alarms are activated when preset number of hours of operation is reached. By default the settings are 1600hrs for Clean UV alarm and 13000 for UV End of Life. Those statistics don't reset automatically so it can be calculated how long overdue those services are. To reset those statistics a user name and password are required. UV stays on when alarm active.

“Filter removed” – when during operation a filter is removed from a hood, contacts connected to terminals 17 and 1 will activate this alarm. UV in affected hood is turned off.

“UV door open” - if during operation any of hood UV access door is open, contacts connected to terminals 16 and 1 will activate this alarm. UV in affected hood is turned off.

CRITICAL ALARMS

Critical alarms cause the UV to be turned off. The critical alarms are: “Low airflow”, “Filter removed” and “UV door open”.

Understanding critical alarms.

When one of those critical alarms occurs, the screen switches automatically to “Alarm info” screen and displays the alarm on a red backlit screen. The system status remains “System On” however UV status shows “UV off”.

It is important to understand that the UV output from the control panel remains “on” to keep all UV hoods operational. Only UV in affected hood is turned off locally by the internal relay in the UV hood compartment. The affected hood can be located by inspecting the LED indicators on face of each hood. Hood with UV off will have all 6 LEDs off.

Field Wiring to UV Control Panel

The panel requires 120V/60Hz, 5Amps supply.

All field wiring is low voltage, 24VAC.

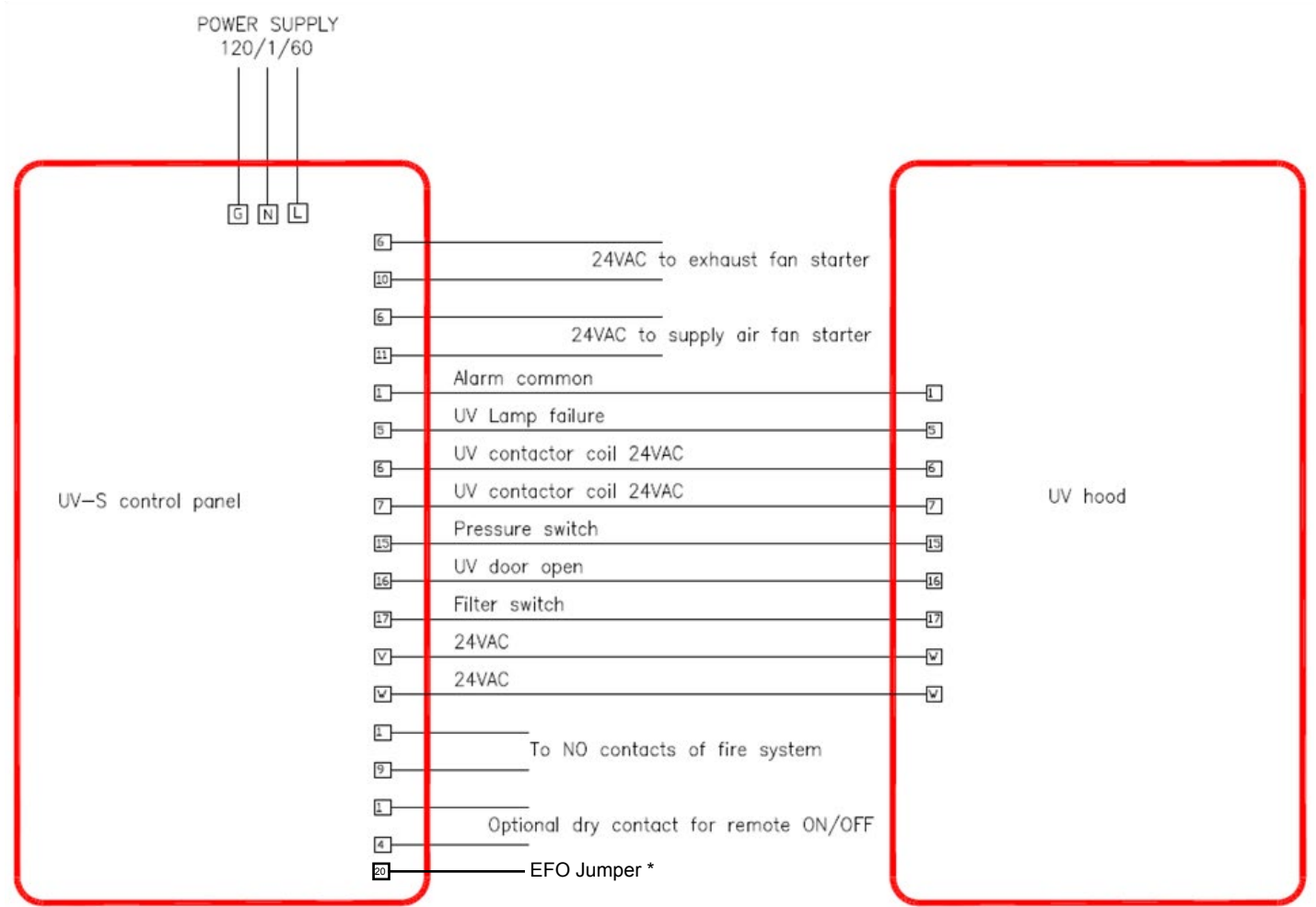

* Install "EFO Jumper" if Exhaust Fan is required to be ON in fire mode.

WARRANTY ACTIVATION FORM

This form must be completed and returned to Halton in order for your warranty to be valid.

Job & Location Information:

Job Name: _____

Street Name: _____

City: _____ State: _____ Zip Code: _____

Equipment Start-Up Date: _____ Product Serial Numbers: _____

Contact Information:

Contact Name: _____

Title: _____

Chef, Kitchen Mgr/Facility Mgr/Property Mgr/etc.

Facility Management Company Name (if applicable): _____

Email: _____

Phone Number: _____ Cell Number: _____

Fax completed form to:

Halton Company

Attention: Service Department

Fax: (270) 237-5700

Halton Indoor Climate Systems

Attention: Service Department

Fax: (905) 624-5547

HALTON LIMITED WARRANTY

Halton ("Manufacturer"). Warrants only to its direct purchasers and to no others, that all products manufactured by the Manufacturer shall be free from defect in materials and workmanship for a period of twelve (12) months from the date of the original installation and start-up or eighteen (18) months from date of shipment, whichever occurs first. All products sold but not manufactured by Manufacturer will be warranted for a period of twelve (12) months from date of shipment. (Halton's Warranty Card must be completely filled out and returned to Halton within 3 weeks after the equipment start-up date for your warranty to be valid *IMPORTANT NOTE: "IF" this form is returned within the specified time frame, Halton will extend your standard warranty by 120 days.)

For products manufactured by the Manufacturer we agree to pay any reasonable labor costs necessary to repair or replace, at Manufacturers option, defective parts or materials for a period of twelve (12) months from date of original installation and start-up or eighteen (18) months from date of shipment, whichever occurs first. All labor costs subject hereto shall be performed during standard work hours at straight-time rates.

For products sold but not manufactured by the Manufacturer we agree to pay any reasonable labor costs necessary to repair or replace, at Manufacturers option, defective parts or materials for a period of (90) days from date of original installation and start-up or (12) months from date of shipment, whichever occurs first. All labor costs subject hereto shall be performed during standard work hours at straight time rates.

All warranty claims that include labor requires pre-approval by Halton. Halton, at its discretion, will authorize field warranty work through its own service network or certified third party. No claims for labor charges will be approved for payment if work commences without prior authorization by Halton.

Purchaser shall pay incurred premium labor charge, including overtime, weekends and holidays. Travel time, service charges, miscellaneous tools, material charges, and labor charges resulting from inaccessibility of equipment will not be paid by Manufacturer.

This LIMITED WARRANTY SHALL APPLY ONLY to products that have been installed and maintained in accordance with the installation and Care Instruction Manuals. Purchaser shall be solely responsible for adhering to the instructions and procedures set forth in the said instruction manuals.

This LIMITED WARRANTY SHALL NOT BE APPLICABLE to any damage or defect resulting from fire, flood, freezing or any Act of God, abuse, misuse, accident, neglect or failure to adhere to all instructions set forth in the installation and Care Instruction Manuals. Furthermore, this limited warranty shall not apply to any product that has been altered, unless such alteration has been approved in writing by a duly authorized representative of the manufacturer. In no event shall the manufacturer be liable for any loss, expense, personal injury or consequential damage, of any kind or character, as may result from a defect in material, and/or workmanship, however caused.

EXCEPT AS IS EXPRESSLY SET FORTH IN THIS LIMITED WARRANTY, MANUFACTURER MAKES NO WARRANTY OF MARKETABILITY FOR FITNESS OR ANY PARTICULAR PURPOSE. NEITHER DOES MANUFACTURER MAKE ANY WARRANTY, EXPRESSED OR IMPLIED, WITH RESPECT TO PRODUCTS SOLD BY MANUFACTURER OR AS TO THE USE THEREOF.

Continuous product improvement is a Halton policy, therefore specifications and design are subject to change without notice.

Halton Company

101 Industrial Drive, Scottsville, KY 42164, USA
Phone 270 237 5600 | Fax 270 237 5700
Website: www.halton.com

Halton Indoor Climate Systems, Ltd.

1021 Brevik Place, Mississauga, ON L4W 3R7, Canada
Phone 905 624 0301 | Fax 905 624 0301

