

UTA GASTIGHT SHUT-OFF DAMPER

For high pressure ductworks



MATERIALS

PART	MATERIAL	FINISHING
Frame	Carbon steel	Painted or galvanised
Frame	Stainless steel EN 1.4301 (AISI 304), EN 1.4404 (AISI 316L), EN 1.4432 (AISI 316L)	Painted as an option
Blades	Steel	Galvanised
Blades	Stainless steel EN 1.4301 (AISI 304), EN 1.4404 (AISI 316L), EN 1.4432 (AISI 316L)	-
Maintenance-free bearings	Oil bronze Stainless steel EN 1.4404 (AISI 316L) available as an option	-
Shafts	Stainless steel EN 1.4404 (AISI 316L)	-

PRODUCT OPTIONS

Halton UTA is available with following actuators:

- UTA-EL: Electrical spring return actuator; standard actuators being 24 VAC/DC, 230 VAC or 120 VAC. Depending on the choice of actuator, the actuator might contain built-in open-closed limit switches. A wide range of Ex actuators available, including a one second closing time function as an option (for limited sizes).
- UTA-PNR: Pneumatic rotating actuator
- UTA-MAN: Manual handle

HSO: Halton Smart Override function for HVAC damper black-start available for PNR and EL models. With automatic reset function when power and/or pneumatic air supply is reinstated.

A wide range of accessories available.

APPLICATIONS

Halton UTA dampers are used to shut off and balance airflow rates in high-pressure ductwork. The dampers meet international standards for rectangular and round ducts. In the open position, the blades align with the direction of flow and do not cause significant pressure loss. The UTA functions as a shut-off, gas, and balancing damper in applications where tightness and reliability are crucial.

FEATURES

- For shutting off and balancing air intake and exhaust ducts
- A closed damper fulfils the requirement of leakage class 3 (EN1751:2014) for sizes $\geq 300 \times 300$ mm (stainless steel seals) and sizes $\geq 150 \times 150$ mm (silicon seals)
- Classification of casing leakage (EN1751:2014) class C
- The outer frame is available in galvanised, painted, or stainless steel. Blades are made of galvanised or stainless steel with double-sheet construction. Blades contain stainless steel spring seals for low leakage, with silicon sealing as an option
- Earthing stud included as standard
- Electrical, pneumatic, or manual operation systems available
- UTA dampers can be supplied with connection pieces for round ducts
- Maximum duct pressure for damper construction: 5000 Pa, and maximum air velocity: 15 m/s
- Normal operating temperature for the damper ranges from -50°C to $+80^{\circ}\text{C}$. Actuator and component selection can affect this temperature range. Other temperatures available on request
- Available as ATEX certified
- SIL 2 safety assessment certificate available under specific terms

INSTALLATION

For installation on a wall or roof. When installed on a wall, the blade orientation must always be in a horizontal plane.

GENERAL DRAWINGS

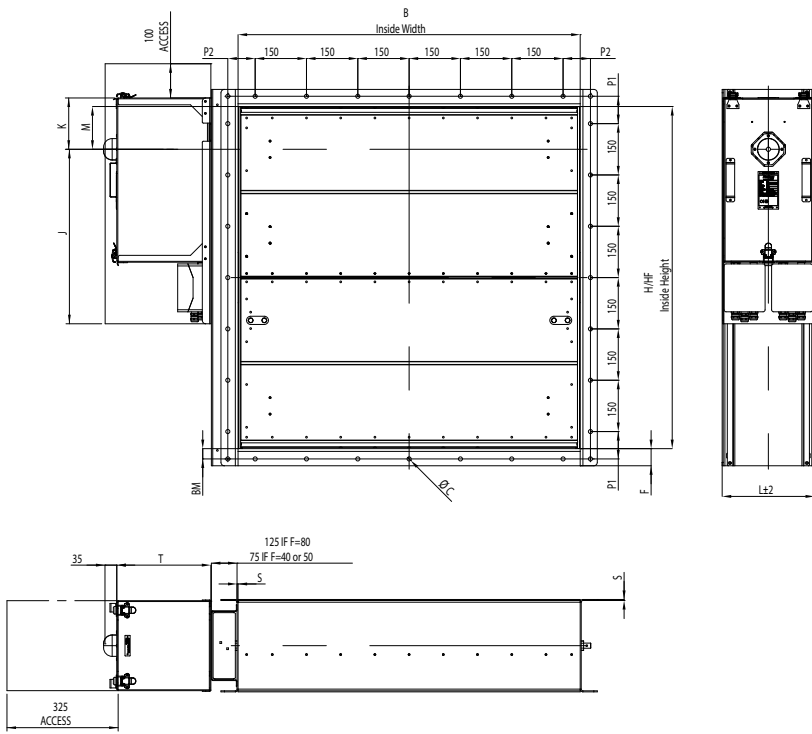

ACTUATOR	J	K	T
AT100	430	150	145
AT100 + Halton smart override	510	150	255
AT200	510	150	165
AT200 + Halton smart override	510	150	275
AT300	510	180	190
AT300 + Halton smart override	510	180	300
Belimo BF	430	150	125
Belimo BF (damper height <200)	430	90	125
Schischek S	430	150	145
Schischek S (damper height <200)	430	90	145
Schischek S + Halton smart override	440	220	235
Schischek M	510	150	175
Schischek M + Halton smart override	440	220	165

MATERIAL THICKNESS	DEPTH
S	L
3	270
5	275

H NOMINAL HEIGHT	HF FREE HEIGHT	M DRIVE
100	100	50
150	150	75
200	200	100
250	250	125
300	250	125
350	250	125
400	400	100
450	450	125
500	500	125
550	500	125
600	600	100
650	650	125
700	700	125
750	750	125
800	800	100
850	850	125
900	900	125
950	950	125
1000	1000	125
1050	1050	125
1100	1100	125
1150	1150	125
1200	1200	125
1250	1250	125
1300	1300	125
1350	1350	125
1400	1400	125
1450	1450	125
1500	1500	125
1550	1500	125
1600	1500	125

M07Y2024/Halton reserves the right to alter products without notice.

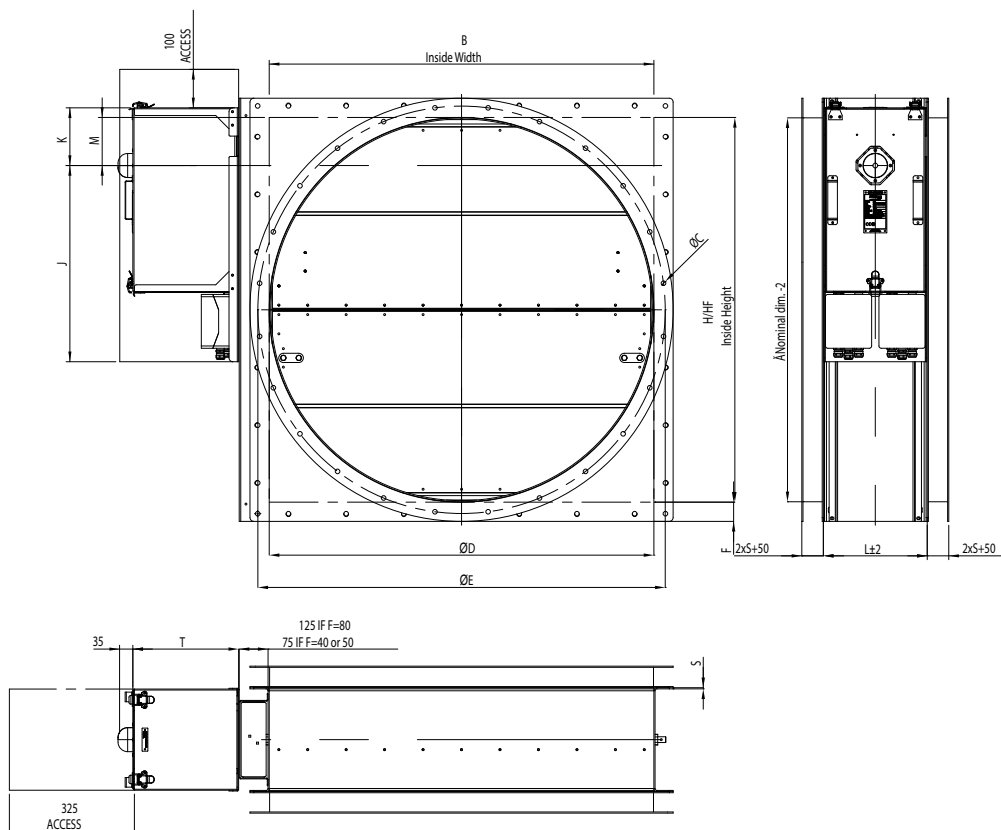

Flange dimensions according to ISO 15138

Nominal Duct Size (Ø D)	Bolt Circle (Ø E)	Bolt hole Size	No. Of Bolts
100	145	10	4
125	170	10	4
150	195	10	4
160	205	10	4
200	245	10	8
250	295	10	8
275	320	10	8
300	345	10	8
315	360	10	8
355	400	10	8
400	459	12	8
450	509	12	12
500	559	12	12
560	619	12	12
600	659	12	16
630	689	12	16
700	759	12	16
710	769	12	16
800	859	12	24
900	959	12	24
1000	1059	12	24
1120	1209	14	24
1200	1289	14	32
1250	1339	14	32
1400	1489	14	32

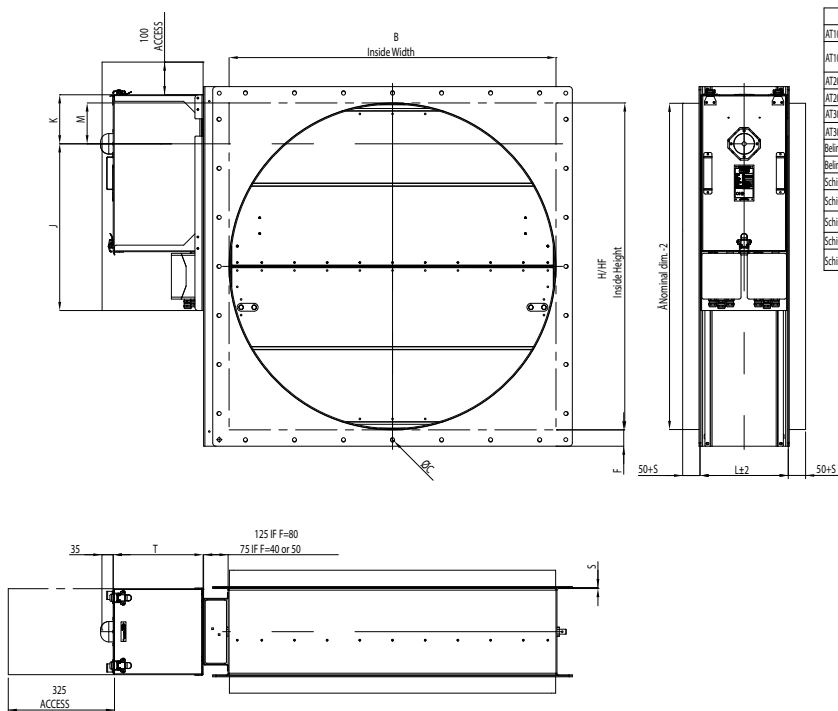

Actuator	J	K	T
AT100	450	950	145
AT100-Halton smart override	510	950	225
AT200	510	950	165
AT200-Halton smart override	510	950	225
AT300	510	980	190
AT300-Halton smart override	510	980	300
Bellmo BF	430	950	125
Bellmo BF (Damper height < 200)	430	90	125
Schischek S	430	950	145
Schischek S (Damper height < 200)	430	90	145
Schischek S-Halton smart override	440	220	235
Schischek M	510	950	175
Schischek M-Halton smart override	440	220	165

H	H/IF	M
Nominal height	Free height	Drive
100	100	50
150	150	75
200	200	100
250	250	125
300	250	125
350	250	125
400	400	100
450	450	125
500	500	125
550	500	125
600	600	100
650	650	125
700	700	125
750	750	125
800	800	100
850	850	125
900	900	125
950	950	125
1000	1000	125
1050	1050	125
1100	1100	125
1150	1150	125
1200	1200	125
1250	1250	125
1300	1300	125
1350	1350	125
1400	1400	125
1450	1450	125
1500	1500	125
1550	1500	125
1600	1500	125

DIMENSIONS AND MATERIAL THICKNESS

UTA dampers meet international standards for both rectangular (width B 100-1200 mm with 25 mm division and height H 100-1600 mm with 50 mm division) and circular ducts (\varnothing 200-1250 mm). Modular constructions up to 2500x2600 mm available. For bigger sizes, contact Halton.

Non-standard dimensions and flange drilling available on request. Standard flanges and drilling according to ISO 15138 standards. Frame thickness 3 or 5 mm.

FLANGE DIMENSIONS ACCORDING TO ISO 15138

DIMENSIONS	\varnothing C	F	P1	P2	BM
If longest side \leq 350	10	40	75...150	75...150	20
If longest side 351...1000	12	50	75...150	75...150	30
If longest side \geq 1001	14	80	75...150	75...150	40

CIRCULAR FLANGE DIMENSIONS ACCORDING TO ISO 15138

DIMENSIONS	\varnothing C	F
If \varnothing D \leq 355	10	40
If \varnothing D 356...1000	12	50
If \varnothing D \geq 1001	14	80

WEIGHTS

STANDARD HALTON UTA DAMPERS (KG) WITHOUT AN ACTUATOR. FRAME THICKNESS 3 MM.

H / HEIGHT (mm)	B / WIDTH (mm)												D2 ØD (mm)	WEIGHT (kg)
	100	200	300	400	500	600	700	800	900	1000	1100	1200		
100	7.5	10.3	13.2	16.0	18.8	21.7	24.5	27.4	30.2	33.0	35.9	38.7	100	9
200	10.8	13.6	16.5	19.3	22.2	25.0	27.8	30.7	33.5	36.4	39.2	42.0	125	10
300	14.1	17.0	19.8	22.7	25.5	28.3	31.2	34.0	36.9	39.7	42.5	45.4	160	14
400	18.7	22.0	25.3	28.6	31.9	35.2	38.5	41.8	45.1	48.4	51.6	54.9	200	18
500	22.5	25.8	29.1	32.4	35.7	39.0	42.3	45.6	48.8	52.1	55.4	58.7	250	22
600	27.1	30.9	34.6	38.3	42.1	45.8	49.6	53.3	57.0	60.8	64.5	68.3	315	25
700	30.9	34.6	38.4	42.1	45.9	49.6	53.3	57.1	60.8	64.6	68.3	72.0	400	38
800	35.5	39.7	43.9	48.1	52.3	56.5	60.7	64.8	69.0	73.2	77.4	81.6	500	47
900	39.3	43.5	47.7	51.9	56.1	60.2	64.4	68.6	72.8	77.0	81.2	85.4	630	59
1000	43.1	47.3	51.5	55.6	59.8	64.0	68.2	72.4	76.6	80.8	85.0	89.2	800	86
1100	47.7	52.3	57.0	61.6	66.2	70.9	75.5	80.2	84.8	89.4	94.1	98.7	1000	109
1200	51.5	56.1	60.7	65.4	70.0	74.7	79.3	83.9	88.6	93.2	97.9	102.5	1250	148
1300	56.1	61.2	66.2	71.3	76.4	81.5	86.6	91.7	96.8	101.9	107.0	112.1		
1400	59.8	64.9	70.0	75.1	80.2	85.3	90.4	95.5	100.6	105.7	110.7	115.8		
1500	63.6	68.7	73.8	78.9	84.0	89.1	94.2	99.3	104.3	109.4	114.5	119.6		
1600	67.4	72.5	77.6	82.7	87.8	92.9	97.9	103.0	108.1	113.2	118.3	123.4		

Flanges according to ISO 15138.

STANDARD HALTON UTA DAMPERS (KG) WITHOUT AN ACTUATOR. FRAME THICKNESS 5 MM.

H / HEIGHT (mm)	B / WIDTH (mm)												D2 ØD (mm)	WEIGHT (kg)
	100	200	300	400	500	600	700	800	900	1000	1100	1200		
100	9.0	13.2	17.5	21.7	26.0	30.2	34.5	38.7	42.9	47.2	51.4	55.7	100	12
200	13.7	18.0	22.2	26.5	30.7	34.9	39.2	43.4	47.7	51.9	56.2	60.4	125	13
300	18.5	22.7	26.9	31.2	35.4	39.7	43.9	48.2	52.4	56.7	60.9	65.2	160	19
400	24.5	29.2	33.9	38.5	43.2	47.9	52.6	57.3	62.0	66.7	71.4	76.1	200	24
500	29.6	34.3	39.0	43.7	48.4	53.1	57.8	62.5	67.2	71.9	76.6	81.3	250	26
600	35.7	40.8	46.0	51.1	56.2	61.4	66.5	71.7	76.8	82.0	87.1	92.3	315	36
700	40.8	46.0	51.1	56.3	61.4	66.6	71.7	76.9	82.0	87.2	92.3	97.5	400	54
800	46.9	52.5	58.0	63.6	69.2	74.8	80.4	86.0	91.6	97.2	102.8	108.4	500	68
900	52.0	57.6	63.2	68.8	74.4	80.0	85.6	91.2	96.8	102.4	108.0	113.6	630	84
1000	57.2	62.8	68.4	74.0	79.6	85.2	90.8	96.4	102.0	107.6	113.2	118.8	800	121
1100	63.2	69.3	75.3	81.4	87.4	93.5	99.5	105.6	111.6	117.7	123.7	129.7	1000	154
1200	68.4	74.5	80.5	86.6	92.6	98.7	104.7	110.7	116.8	122.8	128.9	134.9	1250	212
1300	74.4	80.9	87.4	93.9	100.4	106.9	113.4	119.9	126.4	132.9	139.4	145.9		
1400	79.6	86.1	92.6	99.1	105.6	112.1	118.6	125.1	131.6	138.1	144.6	151.1		
1500	84.8	91.3	97.8	104.3	110.8	117.3	123.8	130.3	136.8	143.3	149.8	156.3		
1600	90.0	96.5	103.0	109.5	116.0	122.5	129.0	135.5	142.0	148.5	155.0	161.4		

Flanges according to ISO 15138.

PNEUMATIC ACTUATORS FOR UTA ACCORDING TO THE SIZE OF THE DAMPER

DAMPER BLADES WITH STAINLESS STEEL SEALS

H / HEIGHT (mm)	B / WIDTH (mm)											
	100	200	300	400	500	600	700	800	900	1000	1100	1200
100	AT100	AT100	AT100	AT100	AT100	AT100	AT100	AT200	AT200	AT200	AT200	AT200
200	AT100	AT100	AT100	AT100	AT100	AT100	AT100	AT200	AT200	AT200	AT200	AT200
300	AT100	AT100	AT100	AT100	AT100	AT100	AT100	AT200	AT200	AT200	AT200	AT200
400	AT100	AT100	AT100	AT100	AT100	AT200	AT200	AT200	AT200	AT200	AT200	AT200
500	AT100	AT100	AT100	AT100	AT100	AT200	AT200	AT200	AT200	AT200	AT200	AT200
600	AT100	AT100	AT100	AT200	AT200	AT200	AT200	AT200	AT200	AT200	AT300	AT300
700	AT100	AT100	AT100	AT200	AT200	AT200	AT200	AT200	AT200	AT200	AT300	AT300
800	AT100	AT100	AT100	AT200	AT200	AT200	AT200	AT200	AT300	AT300	AT300	AT300
900	AT100	AT100	AT100	AT200	AT200	AT200	AT200	AT200	AT300	AT300	AT300	AT300
1000	AT100	AT100	AT100	AT200	AT200	AT200	AT200	AT200	AT300	AT300	AT300	AT300
1100	AT100	AT100	AT200	AT200	AT200	AT200	AT200	AT300	AT300	AT300	AT300	AT300
1200	AT100	AT100	AT200	AT200	AT200	AT200	AT200	AT300	AT300	AT300	AT300	AT300
1300	AT100	AT100	AT200	AT200	AT200	AT200	AT300	AT300	AT300	AT300	AT300	AT300
1400	AT100	AT100	AT200	AT200	AT200	AT200	AT300	AT300	AT300	AT300	AT300	AT300
1500	AT100	AT100	AT200	AT200	AT200	AT200	AT300	AT300	AT300	AT300	AT300	AT300
1600	AT100	AT100	AT200	AT200	AT200	AT200	AT300	AT300	AT300	AT300	AT300	AT300

Approximate weights of pneumatic rotary actuator Air Torque: UTA-PNR AT101 as aluminium +1,8 kg, AT104 as stainless steel 4,0 kg, AT201 as aluminium +3,2kg, AT204 as stainless steel +6,4 kg, AT301 as aluminium +6,0 kg, AT304 as stainless steel +13,3 kg. Other actuators available on request.

PNEUMATIC ACTUATORS FOR UTA ACCORDING TO THE SIZE OF THE DAMPER

DAMPER BLADES WITH SILICON SEALS

H / HEIGHT (mm)	B / WIDTH (mm)											
	100	200	300	400	500	600	700	800	900	1000	1100	1200
100	AT100	AT100	AT100	AT100	AT100	AT100	AT100	AT100	AT100	AT100	AT100	AT100
200	AT100	AT100	AT100	AT100	AT100	AT100	AT100	AT100	AT100	AT100	AT100	AT100
300	AT100	AT100	AT100	AT100	AT100	AT100	AT100	AT100	AT100	AT100	AT100	AT100
400	AT100	AT100	AT100	AT100	AT100	AT100	AT100	AT100	AT100	AT100	AT100	AT100
500	AT100	AT100	AT100	AT100	AT100	AT100	AT100	AT100	AT100	AT100	AT100	AT100
600	AT100	AT100	AT100	AT100	AT100	AT100	AT100	AT100	AT100	AT100	AT100	AT100
700	AT100	AT100	AT100	AT100	AT100	AT100	AT100	AT100	AT100	AT100	AT100	AT100
800	AT100	AT100	AT100	AT100	AT100	AT100	AT100	AT100	AT100	AT100	AT100	AT100
900	AT100	AT100	AT100	AT100	AT100	AT100	AT100	AT100	AT100	AT100	AT100	AT100
1000	AT100	AT100	AT100	AT100	AT100	AT100	AT100	AT100	AT100	AT100	AT100	AT100
1100	AT100	AT100	AT100	AT100	AT100	AT100	AT100	AT100	AT100	AT100	AT100	AT100
1200	AT100	AT100	AT100	AT100	AT100	AT100	AT100	AT100	AT100	AT100	AT100	AT100
1300	AT100	AT100	AT200	AT200	AT200	AT200	AT200	AT200	AT200	AT200	AT200	AT200
1400	AT100	AT100	AT200	AT200	AT200	AT200	AT200	AT200	AT200	AT200	AT200	AT200
1500	AT100	AT100	AT200	AT200	AT200	AT200	AT200	AT200	AT200	AT200	AT200	AT200
1600	AT100	AT100	AT200	AT200	AT200	AT200	AT200	AT200	AT200	AT200	AT200	AT200

Approximate weights of pneumatic rotary actuator Air Torque: UTA-PNR AT101 as aluminium +1,8 kg, AT104 as stainless steel 4,0 kg, AT201 as aluminium +3,2kg, AT204 as stainless steel +6,4 kg, AT301 as aluminium +6,0 kg, AT304 as stainless steel +13,3 kg. Other actuators available on request.

M07Y2024/Halton reserves the right to alter products without notice.

ELECTRIC ACTUATORS FOR UTA ACCORDING TO THE SIZE OF THE DAMPER

BLADES WITH SILICON SEALS

H / HEIGHT (mm)	B / WIDTH (mm)											
	100	200	300	400	500	600	700	800	900	1000	1100	1200
100	Ex/Inmax-15-SF Belimo BF	Ex/Inmax-15-SF Belimo BF	Ex/Inmax-15-SF Belimo BF	Ex/Inmax-15-SF Belimo BF	Ex/Inmax-15-SF Belimo BF	Ex/Inmax-15-SF Belimo BF	Ex/Inmax-15-SF Belimo BF	Ex/Inmax-15-SF Belimo BF	Ex/Inmax-15-SF Belimo BF	Ex/Inmax-15-SF Belimo BF	Ex/Inmax-15-SF Belimo BF	Ex/Inmax-15-SF Belimo BF
200	Ex/Inmax-15-SF Belimo BF	Ex/Inmax-15-SF Belimo BF	Ex/Inmax-15-SF Belimo BF	Ex/Inmax-15-SF Belimo BF	Ex/Inmax-15-SF Belimo BF	Ex/Inmax-15-SF Belimo BF	Ex/Inmax-15-SF Belimo BF	Ex/Inmax-15-SF Belimo BF	Ex/Inmax-15-SF Belimo BF	Ex/Inmax-15-SF Belimo BF	Ex/Inmax-15-SF Belimo BF	Ex/Inmax-15-SF Belimo BF
300	Ex/Inmax-15-SF Belimo BF	Ex/Inmax-15-SF Belimo BF	Ex/Inmax-15-SF Belimo BF	Ex/Inmax-15-SF Belimo BF	Ex/Inmax-15-SF Belimo BF	Ex/Inmax-15-SF Belimo BF	Ex/Inmax-15-SF Belimo BF	Ex/Inmax-15-SF Belimo BF	Ex/Inmax-15-SF Belimo BF	Ex/Inmax-15-SF Belimo BF	Ex/Inmax-15-SF Belimo BF	Ex/Inmax-15-SF Belimo BF
400	Ex/Inmax-15-SF Belimo BF	Ex/Inmax-15-SF Belimo BF	Ex/Inmax-15-SF Belimo BF	Ex/Inmax-15-SF Belimo BF	Ex/Inmax-15-SF Belimo BF	Ex/Inmax-15-SF Belimo BF	Ex/Inmax-15-SF Belimo BF	Ex/Inmax-15-SF Belimo BF	Ex/Inmax-15-SF Belimo BF	Ex/Inmax-15-SF Belimo BF	Ex/Inmax-15-SF Belimo BF	Ex/Inmax-15-SF Belimo BF
500	Ex/Inmax-15-SF Belimo BF	Ex/Inmax-15-SF Belimo BF	Ex/Inmax-15-SF Belimo BF	Ex/Inmax-15-SF Belimo BF	Ex/Inmax-15-SF Belimo BF	Ex/Inmax-15-SF Belimo BF	Ex/Inmax-15-SF Belimo BF	Ex/Inmax-15-SF Belimo BF	Ex/Inmax-15-SF Belimo BF	Ex/Inmax-15-SF Belimo BF	Ex/Inmax-15-SF Belimo BF	Ex/Inmax-15-SF Belimo BF
600	Ex/Inmax-15-SF Belimo BF	Ex/Inmax-15-SF Belimo BF	Ex/Inmax-15-SF Belimo BF	Ex/Inmax-15-SF Belimo BF	Ex/Inmax-15-SF Belimo BF	Ex/Inmax-15-SF Belimo BF	Ex/Inmax-15-SF Belimo BF	Ex/Inmax-15-SF Belimo BF	Ex/Inmax-15-SF Belimo BF	Ex/Inmax-15-SF Belimo BF	Ex/Inmax-15-SF Belimo BF	Ex/Inmax-15-SF Belimo BF
700	Ex/Inmax-15-SF Belimo BF	Ex/Inmax-15-SF Belimo BF	Ex/Inmax-15-SF Belimo BF	Ex/Inmax-15-SF Belimo BF	Ex/Inmax-15-SF Belimo BF	Ex/Inmax-15-SF Belimo BF	Ex/Inmax-15-SF Belimo BF	Ex/Inmax-15-SF Belimo BF	Ex/Inmax-15-SF Belimo BF	Ex/Inmax-15-SF Belimo BF	Ex/Inmax-15-SF Belimo BF	Ex/Inmax-15-SF Belimo BF
800	Ex/Inmax-15-SF Belimo BF	Ex/Inmax-15-SF Belimo BF	Ex/Inmax-15-SF Belimo BF	Ex/Inmax-15-SF Belimo BF	Ex/Inmax-15-SF Belimo BF	Ex/Inmax-15-SF Belimo BF	Ex/Inmax-15-SF Belimo BF	Ex/Inmax-15-SF Belimo BF	Ex/Inmax-15-SF Belimo BF	Ex/Inmax-15-SF Belimo BF	Ex/Inmax-15-SF Belimo BF	Ex/Inmax-15-SF Belimo BF
900	Ex/Inmax-15-SF Belimo BF	Ex/Inmax-15-SF Belimo BF	Ex/Inmax-15-SF Belimo BF	Ex/Inmax-15-SF Belimo BF	Ex/Inmax-15-SF Belimo BF	Ex/Inmax-15-SF Belimo BF	Ex/Inmax-15-SF Belimo BF	Ex/Inmax-15-SF Belimo BF	Ex/Inmax-15-SF Belimo BF	Ex/Inmax-15-SF Belimo BF	Ex/Inmax-15-SF Belimo BF	Ex/Inmax-15-SF Belimo BF
1000	Ex/Inmax-15-SF Belimo BF	Ex/Inmax-15-SF Belimo BF	Ex/Inmax-15-SF Belimo BF	Ex/Inmax-15-SF Belimo BF	Ex/Inmax-15-SF Belimo BF	Ex/Inmax-15-SF Belimo BF	Ex/Inmax-15-SF Belimo BF	Ex/Inmax-15-SF Belimo BF	Ex/Inmax-15-SF Belimo BF	Ex/Inmax-15-SF Belimo BF	Ex/Inmax-15-SF Belimo BF	Ex/Inmax-15-SF Belimo BF
1100	Ex/Inmax-15-SF Belimo BF	Ex/Inmax-15-SF Belimo BF	Ex/Inmax-15-SF Belimo BF	Ex/Inmax-15-SF Belimo BF	Ex/Inmax-15-SF Belimo BF	Ex/Inmax-15-SF Belimo BF	Ex/Inmax-15-SF Belimo BF	Ex/Inmax-15-SF Belimo BF	Ex/Inmax-15-SF Belimo BF	Ex/Inmax-15-SF Belimo BF	Ex/Inmax-15-SF Belimo BF	Ex/Inmax-15-SF Belimo BF
1200	Ex/Inmax-15-SF Belimo BF	Ex/Inmax-15-SF Belimo BF	Ex/Inmax-15-SF Belimo BF	Ex/Inmax-15-SF Belimo BF	Ex/Inmax-15-SF Belimo BF	Ex/Inmax-15-SF Belimo BF	Ex/Inmax-15-SF Belimo BF	Ex/Inmax-15-SF Belimo BF	Ex/Inmax-15-SF Belimo BF	Ex/Inmax-15-SF Belimo BF	Ex/Inmax-15-SF Belimo BF	Ex/Inmax-15-SF Belimo BF
1300	Ex/Inmax-15-SF Belimo BF	Ex/Inmax-15-SF Belimo BF	Ex/Inmax-15-SF Belimo BF	Ex/Inmax-15-SF Belimo BF	Ex/Inmax-15-SF Belimo BF	Ex/Inmax-15-SF Belimo BF	Ex/Inmax-15-SF Belimo BF	Ex/Inmax-15-SF Belimo BF	Ex/Inmax-15-SF Belimo BF	Ex/Inmax-15-SF Belimo BF	Ex/Inmax-15-SF Belimo BF	Ex/Inmax-15-SF Belimo BF
1400	Ex/Inmax-15-SF Belimo BF	Ex/Inmax-15-SF Belimo BF	Ex/Inmax-15-SF Belimo BF	Ex/Inmax-15-SF Belimo BF	Ex/Inmax-15-SF Belimo BF	Ex/Inmax-15-SF Belimo BF	Ex/Inmax-15-SF Belimo BF	Ex/Inmax-15-SF Belimo BF	Ex/Inmax-15-SF Belimo BF	Ex/Inmax-15-SF Belimo BF	Ex/Inmax-15-SF Belimo BF	Ex/Inmax-15-SF Belimo BF
1500	Ex/Inmax-15-SF Belimo BF	Ex/Inmax-15-SF Belimo BF	Ex/Inmax-15-SF Belimo BF	Ex/Inmax-15-SF Belimo BF	Ex/Inmax-15-SF Belimo BF	Ex/Inmax-15-SF Belimo BF	Ex/Inmax-15-SF Belimo BF	Ex/Inmax-15-SF Belimo BF	Ex/Inmax-15-SF Belimo BF	Ex/Inmax-15-SF Belimo BF	Ex/Inmax-15-SF Belimo BF	Ex/Inmax-15-SF Belimo BF
1600	Ex/Inmax-15-SF Belimo BF	Ex/Inmax-15-SF Belimo BF	Ex/Inmax-15-SF Belimo BF	Ex/Inmax-15-SF Belimo BF	Ex/Inmax-15-SF Belimo BF	Ex/Inmax-15-SF Belimo BF	Ex/Inmax-15-SF Belimo BF	Ex/Inmax-15-SF Belimo BF	Ex/Inmax-15-SF Belimo BF	Ex/Inmax-15-SF Belimo BF	Ex/Inmax-15-SF Belimo BF	Ex/Inmax-15-SF Belimo BF

Actuator options	Closing time	Material	Weight (appr.)
ExMax 8-SF1	1 second	Aluminium	3.5 kg
Ex/InMax-15-SF	3 seconds	Aluminium	3.5 kg
Ex/InMax-15-SF	3 seconds	Stainless steel	7.0 kg
Ex/InMax-15-SF1	1 second	Aluminium	3.5 kg
Ex/InMax-15-SF1	1 second	Stainless steel	7.0 kg
Ex/InMax-30-SF3	3 seconds	Aluminium	9.5 kg
Ex/InMax-50-SF3	3 seconds	Aluminium	9.5 kg

Note! Schischek F1 Model (1 sec.)
15 Nm > 0.36 m ²
8 Nm < 0.36 m ²

Actuator options	Material	Weight (appr.)
Ex/InMax-15-F	Aluminium	3.5 kg
Ex/InMax-30-F	Aluminium	9.5 kg
Ex/InMax-50-F	Aluminium	9.5 kg
Ex/InMax-15-F	Stainless steel	7.0 kg
Belimo BF	Steel	3.1 kg
Belimo EF	Steel	4.2 kg