

HME SINGLE DUCT CABIN UNIT

Sound attenuator and balancing box

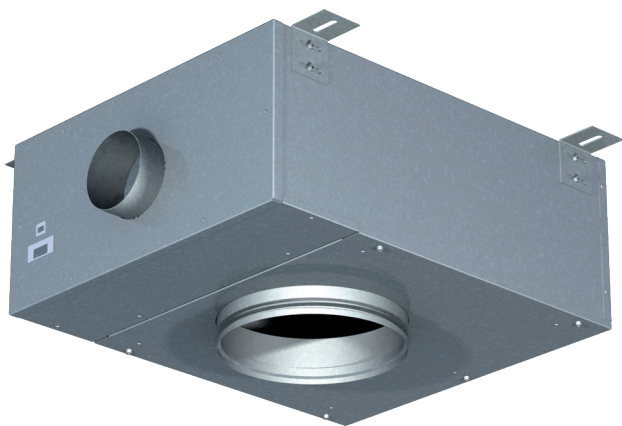

MATERIALS

PART	MATERIAL	NOTE
Casing	Hot galvanised steel	Available as an option: stainless steel EN 1.4404 (AISI316L)
Casing thickness	0.5 mm	As an option: 0.75/1.0 mm
Spigots	Hot galvanised steel and EPDM rubber	Available as an option: stainless steel EN 1.4404 (AISI316L)
Insulation	Mineral wool, s=20 mm, MED approved	As an option: s=25 mm
I/O unit	Aluminium/plastic/electronics	-
Reheat coil	Stainless steel EN 1.4301 (AISI304)	-
Cables	Halogen-free	-
Measurement and adjustment module (MSM) (supply units)	Body: aluminium; plate: hot galvanized; spindle: stainless steel; tubes: polypropylene	-
Adjustment module (MEM) (exhaust units)	Spindle; stainless steel	-

HME PRODUCT OPTIONS

- For supply (with MSM module)
- For supply with reheater and MSM module
- For exhaust (with MEM module)

AVAILABLE REHEATERS

- Standard reheaters: 400W, 800W, 1200 W, 1500W with K01 control package
- Standard reheaters: 400W, 800W, 1200W, 1500W, 1800W with D03 control package

Practical power level may be software adjusted cabin by cabin. Cable and power supply design has to be done according to maximum available heating power.

APPLICATIONS

Halton HME can be used for air distribution and sound attenuation in various applications such as suites and pantries. The unit operates as a plenum box with a balancing and measurement module inside but also fulfils fire safety requirements as standard cabin unit. The supply volume flow rate is determined during commissioning by using the measurement and adjustment device. The airflow measurement tubes and control spindle can be accessed through the unit's outlet. Using the pressure difference readings between the measurement taps and the k coefficient, the corresponding volume flow rate can be calculated. Rotating the control spindle adjusts the volume flow rate until the desired setting is achieved.

FEATURES

- Recommended pressure range from 0 Pa to 200 Pa
- Airflow range 0 m³/h...500 m³/h
- Excellent choice to be used together with HFR/M
- Airflow adjustment with control spindle (MSM module)
- Airflow measurement tubes
- Can be used also as exhaust plenum with MEM airflow adjustment device
- MED approved for B-0/B-15 installations

FEATURES WITH REHEAT MODELS

- 230 VAC ±10%, 50/60 Hz
- Triac controlled reheating coil(s), adjustable heating power (PWM) 0...100%
- Master/slave functionality: several cabin units can be controlled by one control panel
- Internal fuses included
- All parameters can be set onsite during commissioning by external device or preset at the factory
- All cable connections with fast connectors
- Easily tailored for different types of installations
- 90°C safety switch with state detection and manual reset
- HME cabin unit is supplied with control panel and interconnection cable

GENERAL HME DRAWINGS

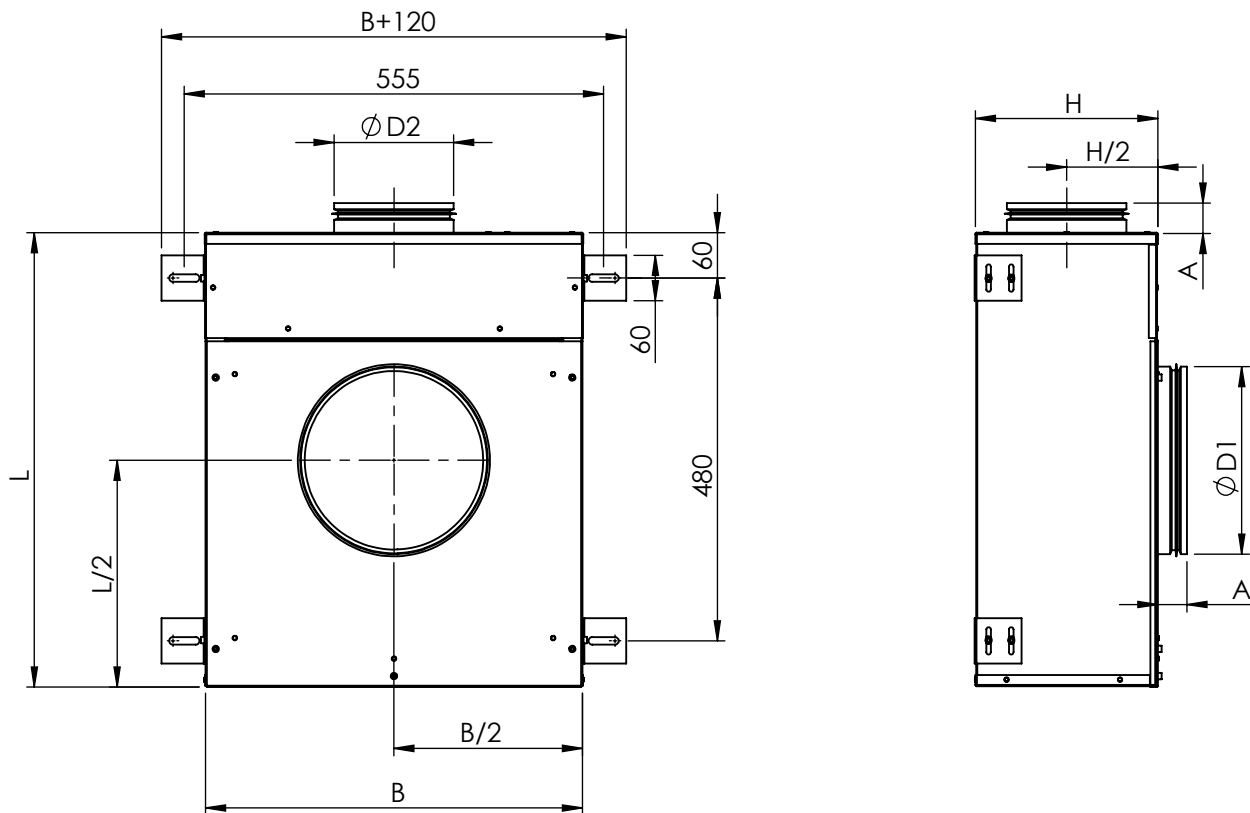

**HME DIMENSIONS,
UNIT MATERIAL THICKNESS 0.5 MM**

	L	B	H	A	ØD1 male/ female	ØD2 male
HME-100	590	490	190	45	159/161	99
HME-125	590	490	190	45	199/201	124
HME-160	590	490	210	45	249/251	159

HME WEIGHTS, KG

Casing thickness	HME-100	HME-125	HME-160
0,5 mm	9,5	10	10,5
0,75/1,0 mm	13,5	14	14,5

Reheater + I/O unit +1Kg

Note: male connection: outer dimension, female connection: inner dimensions. Note: Standard dimensions, modifications possible

**HME DIMENSIONS,
UNIT MATERIAL THICKNESS 0.75/1.0 MM**

	L	B	H	A	ØD1 male/ female	ØD2 male
HME-100	600	500	200	40	159/161	99
HME-125	600	500	200	40	199/201	124
HME-160	600	500	220	40	249/251	159

Note: male connection: outer dimension, female connection: inner dimensions. Note: Standard dimensions, modifications possible

FUNCTION

Correct airflow for HME unit is set during commissioning by adjusting MSM/MEM device in inlet spigot. MSM/MEM is operated by flexible spindle which is easy to access from outlet.

MODELS WITH REHEATER

When passenger demands for warmer temperature by using control panel, the controller activates the electric reheater inside the cabin unit. When the required temperature in the cabin is achieved, the reference is held until the temperature demand changes.

REGULATION DIAGRAM WITH REHEATER

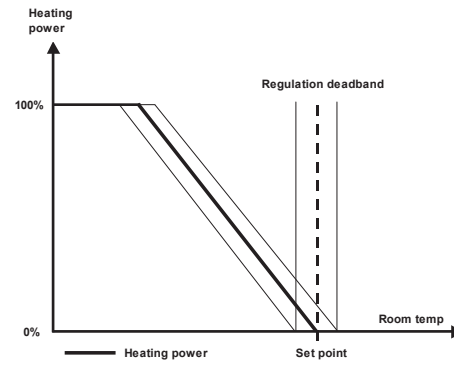

OPERATING RANGE FOR HME WITHOUT REHEATER

HME-100	HME-125	HME-160
50 m ³ /h - 200 m ³ /h	50 m ³ /h - 350 m ³ /h	50 m ³ /h - 500 m ³ /h

OPERATING RANGE FOR HME WITH REHEATER

HME-100	HME-125	HME-160
100 m ³ /h - 200 m ³ /h	100 m ³ /h - 350 m ³ /h	100 m ³ /h - 500 m ³ /h

CONTROL PANEL FEATURES

Halton Marine HME cabin units are available with three different control panel models; with rotating knob, push buttons with LED bar graph (available as option: IP54) and push buttons with LCD-display (available as option: IP54).

COMMON FEATURES

- Cabin temperature measurement
- Connector for bluetooth / communication adapter to set cabin parameters
- Software for parameter setting and trouble shooting
- Different colour options and custom labeling available as an option
- Delivered with IC-Cable (interconnection cable)
 - For control panel - cabin unit connection
 - Prefabricated with plugs on both ends
 - Cable plug on panel side is designed to be pulled through standard installation pipe
 - Halogen free and flame-retardant
 - Standard length 7 meters. Other lengths available.

CONTROL PANEL WITH ROTATING KNOB

- Temperature adjustment by rotating knob

CONTROL PANEL WITH PUSH BUTTONS AND LED BAR GRAPH

- Temperature adjustment by push buttons
- Self diagnose function
- LED intensity control and auto dimming

CONTROL PANEL WITH PUSH BUTTONS AND LCD-DISPLAY

- Temperature adjustment by buttons
- Self diagnose function
- LCD intensity control and auto dimming
- Display for actual and set point temperatures available as an option
- Time display available as an option
- A customized background picture available as an option
- Several frame options available

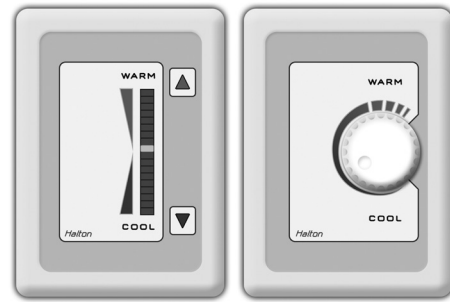

Control panel models; push button and rotating knob

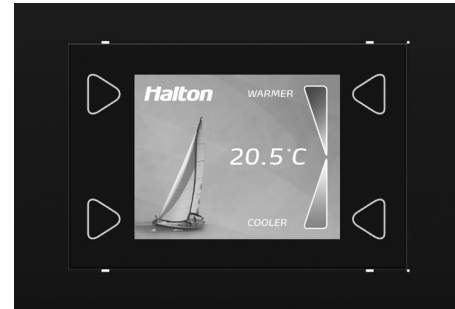

LCD control panel

CABIN VENTILATION CONFIGURATION TABLE

	UNIT	HMM	HMM	HME	HME	HMF	HMF	HMF	HFR/M	HFR/M	HFR/M	HMR	HMR	HML
	CONTROL PACKAGE	K01	D03	K01	D03	M00	M01	M02	M00	M01	M02	D21	H21	B00
TERMINAL UNIT WITH JUNCTION BOX	Damper	Manual	Manual	Manual	Manual	Electric	Electric	Electric	Electric	Electric	Electric	Electric	Electric	Electric
	Airflow measurement and control (VAV, CAV)	No	No	No	No	Yes	No	Yes	Yes	No	Yes	Yes	Yes	Yes
	In-box temperature measurement	Yes	Yes	Yes	Yes	Yes	Yes	Yes	Yes	Yes	Yes	No	No	Yes
	Reheater safety switch, manual reset	Yes	Yes	Yes	Yes	Yes	Yes	Yes	Yes	Yes	Yes	No	No	Yes
	Safety switch state detection	No	Yes	No	Yes	Yes	Yes	Yes	Yes	Yes	Yes	No	No	Yes
	Spare inputs (balcony door etc.)	No	No	No	No	Yes	Yes	Yes	Yes	Yes	Yes	Yes	Yes	Yes
	Parameter setting by service tool	No	Yes	No	Yes	Yes	Yes	Yes	Yes	Yes	Yes	Yes	Yes	Yes
CONTROL PANEL	Cabin temperature measurement	Yes	Yes	Yes	Yes	Yes	Yes	Yes	Yes	Yes	Yes	Yes	Yes	Yes
	Controller with push buttons, 18 led bar	No	Yes	No	Yes	Yes	No	No	Yes	No	No	Yes	No	Yes
	Controller with knob	Yes	No	Yes	No	No	Yes	Yes	No	Yes	Yes	No	Yes	No
	LCD room thermostat	No	Optional	No	Optional	Optional	No	No	Optional	No	No	Optional	No	Optional
	LED intensity control and auto dimming	No	Yes	No	Yes	Yes	No	No	Yes	No	No	Yes	No	Yes
	Self diagnose functionality	No	Yes	No	Yes	Yes	No	No	Yes	No	No	Yes	No	Yes
	Network compatible with adapter	No	Yes	No	Yes	Yes	Yes	Yes	Yes	Yes	Yes	Yes	No	Yes
CO2 sensor available as an option	No	Yes	No	Yes	Yes	No	No	Yes	No	No	Yes	No	Yes	
CABLES	Interconnection cable	IC4-X	IC6-X	IC4-X	IC6-X	IC6-X	IC6-X	IC6-X	IC6-X	IC6-X	IC6-X	IC6-X	IC6-X	IC6-X
	Master-slave cable	MS4-X	MS2-X	MS4-X	MS2-X	MS2-X (MS5-X)	MS3-X	MS3-X	MS2-X (MS5-X)	MS3-X	MS3-X	MS2-X	MS3-X	MS2-X

Please note: HMM and HME units are also available without a control package.

MANUALLY CONTROLLED AIRLOWS

- Single duct units; HMM, HME

PRESSURE DEPENDENT UNITS

- Single duct units; HMF, HFR/M

PRESSURE INDEPENDENT UNITS

- Single duct units; HMF, HFR/M, HML
- Dual duct units; HMR

ACCESSORIES FOR HFR/M CABIN UNITS

MS-CABLE (MASTER-SLAVE CABLE)

- For master cabin unit - slave cabin unit/units connection
- Prefabricated with plugs on both ends
- Halogen free and flame-retardant
- Standard length is 7 meters. Other lengths available as an option.

COMMUNICATION ADAPTER

- Bluetooth communication to external device
- For wireless connection to set cabin unit parameters and trouble shooting

NETWORK ADAPTERS

- Network adapter (also available as WiFi) expands a stand-alone unit to network compatible unit (LON or Ethernet network)
- Enables supervision and advanced energy efficiency functions
- For more information, see Halton Networks for cabin ventilation -brochure or contact Halton Marine Sales office.

MINIMUM SAFETY DISTANCES BEFORE AIRFLOW

MEASUREMENT

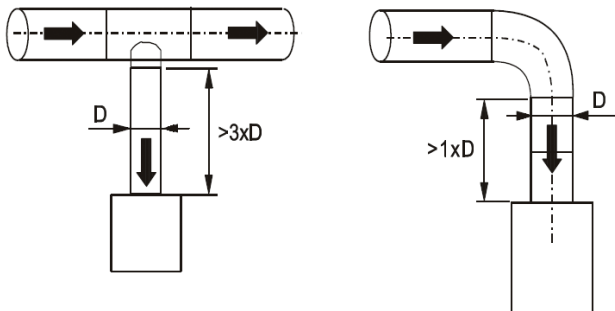

M07\2024\Halton reserves the right to alter products without notice.

PERFORMANCE DATA

SOUND LEVELS, CABIN SOUND ABSORPTION 4 DB(A)

HME/A-125-200

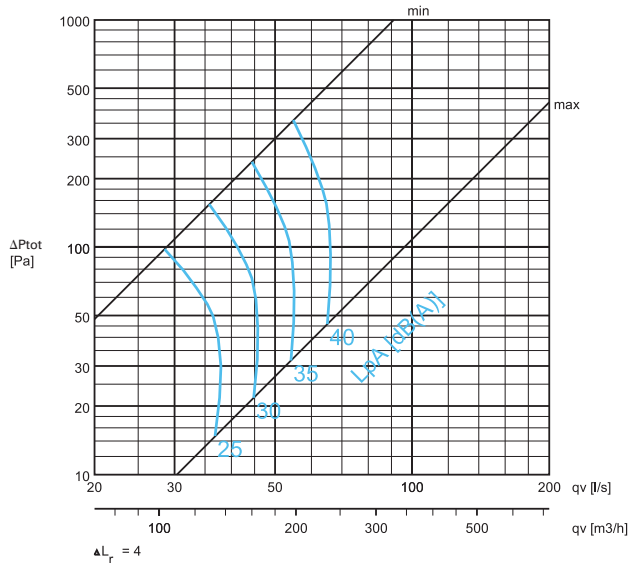

HME/A-160-250

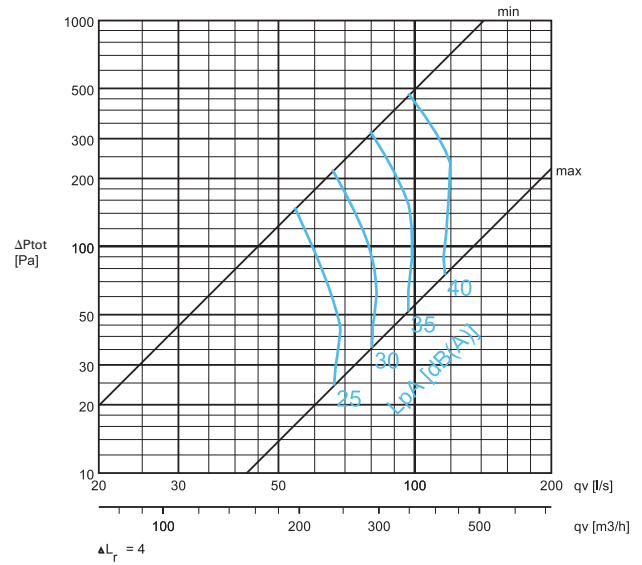

HME/D-125-200

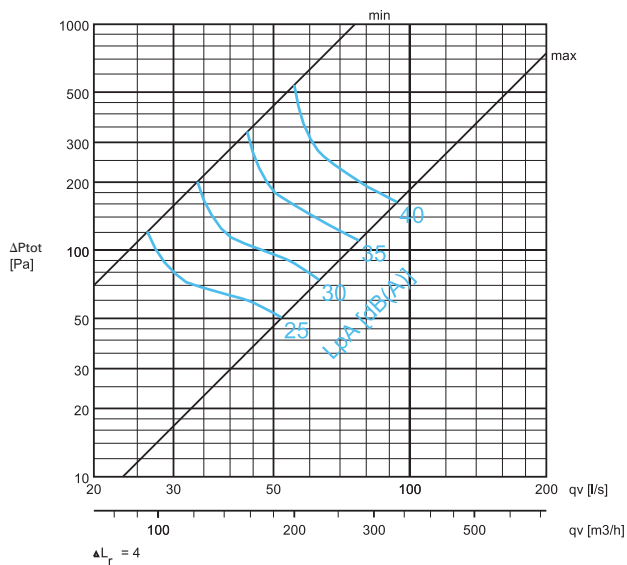

HME/D-160-250

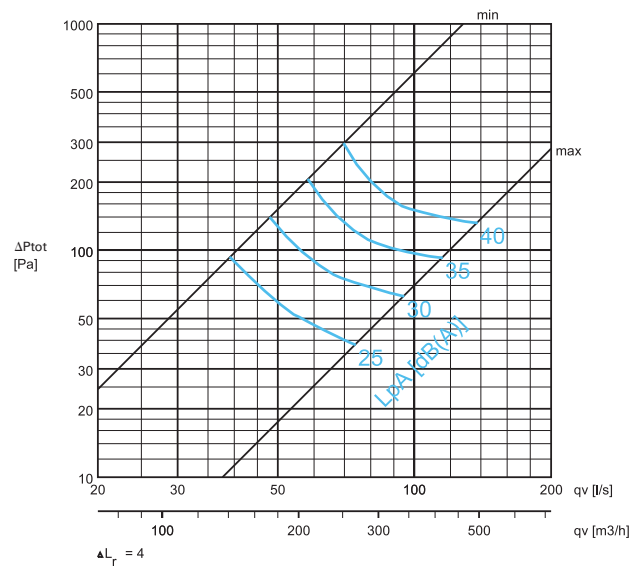

SOUND ATTENUATION (DB)

	f (Hz)	63	125	250	500	1000	2000	4000	8000
HME-125	Ω (dB)	6,4	11,3	15,9	25,8	34,8	37,9	35,3	34,7
HME-160	Ω (dB)	7,2	7,2	17,2	26,7	36,4	40,7	38,5	34,3

Ω : Sound attenuation not including end reflection

M07V2024/Halton reserves the right to alter products without notice.