

DSA HIGH-EFFICIENCY DROPLET SEPARATOR

With heated vanes

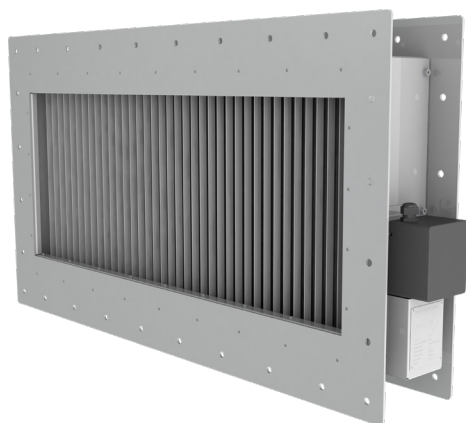

MATERIALS

PART	MATERIAL	FINISHING
Droplet separator	Aluminium EN AW 6060	-
Frame	Aluminium EN AW 5754	Painted RAL9010, C3 acc. standard* ISO 12944-2 as standard
Frame	Stainless steel EN 1.4404 (AISI316L)	Painted as an option
Heating cable	Nickel-plated copper wire, silicone rubber outer jacket (ATEX certified)	-
Junction box	GRP, Eex e II T6 IP66	-

*) C3 durability of 7-15 years. Please note about painting procedures: NORSOK C5-M and Norsok M501 available on request. Please note: Stainless steel junction box available as an option.

GENERAL CONSTRUCTION

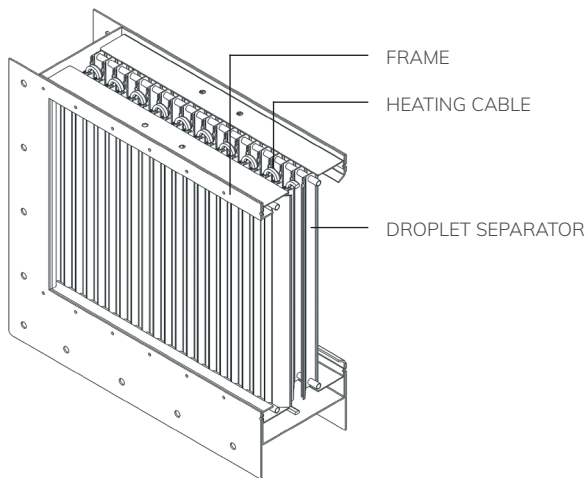

APPLICATIONS

Halton's DSA high-efficiency droplet separators are designed for demanding applications such as oil & gas, chemical, energy and marine industries, where reliability, easy installation and special design play an important role. Droplet separators are designed to restrict the passage of moisture, salt spray, rainwater and airborne aerosol particles e.g. into HVAC systems, engine room intakes, machinery spaces, and diesel and gas turbine air intakes.

DSA droplet separators are fitted with heating elements. The regulated temperature is subject to the surrounding conditions. The actual surface temperature of the heated DSA depends on many variables such as the size of the separator, wind circumstances, face velocity, air temperature and relative humidity. Electrical heating capacities vary between 2,5 kW/m² - 3,7 kW/m², depending on these conditions. The cable heating does not prevent icing in the most severe conditions but it will help defrost the ice when the icing conditions have passed.

When intake air is crucial during extreme icing conditions the Halton ECS (Extreme Conditions Solution) keeps the air intake open. The ECS is available as an option.

FEATURES

- High droplet and moisture separation efficiency
 - Class A results (EN 13030:2001)
 - Minimum pressure drop
- Performance tested according to EN 13030:2001 test for louvres subjected to simulated rain, at the independent laboratory
- Tailored sizes and designs according to customer's needs. Modular construction is available.
- For wall and duct installations
- No special maintenance required
- ATEX certified components II 2 G/D EEx e II T3/T2
- Heating capacity 2,5 kW/m² - 3,7kW/m²
- Operating temperature for DSA -50 °C – +40 °C
- An Extreme Conditions Solution available
- Stainless steel junction box available as an option

GENERAL DSA DRAWINGS

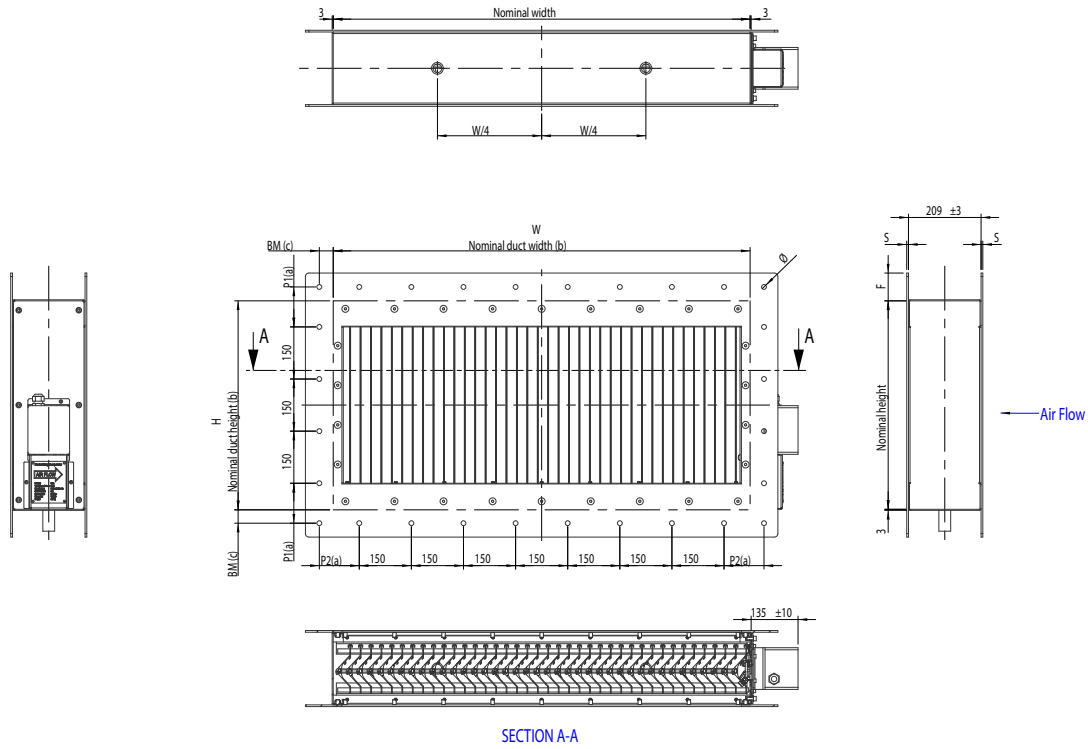

PLEASE NOTE

- 75 mm <P1 & P2 <150 mm
- Width x Height = nominal duct size (internal)
- Back mark BM is the distance from the inside duct to centerline hole

FRAME OPTIONS

- Flange only in front
- Flange only in back
- Flange in front and back
- Without a flange

Flange drilling ISO15138 as standard.

Nominal duct Longest side (mm)	Back mark BM (mm)	Flange F (mm)	Bolt hole size Ø (mm)	Aluminium Flange thickness S (mm)	Stainless steel Flange thickness S (mm)
≤ 350	20	40	10	5	3
> 350 to ≥ 1000	30	50	12	5	3
> 1000	40	80	14	5	5

DSA MINIMUM AND MAXIMUM DIMENSIONS

Minimum size for Halton DSA droplet separator is 300x300 mm (WxH). Maximum size for a single separator is 1500x1200 mm (WxH). Sizes with 50 mm divisions. Modular construction is available up to 3000x2400 mm (WxH).

MATERIAL THICKNESS

Standard frame thickness of 3 mm. Larger thicknesses are available as an option.

DSA DRAIN PIPE

Threaded drain pipes are welded to the bottom of the droplet separator. The thread type is 1" BSPT (male).

DRAIN LOCATIONS

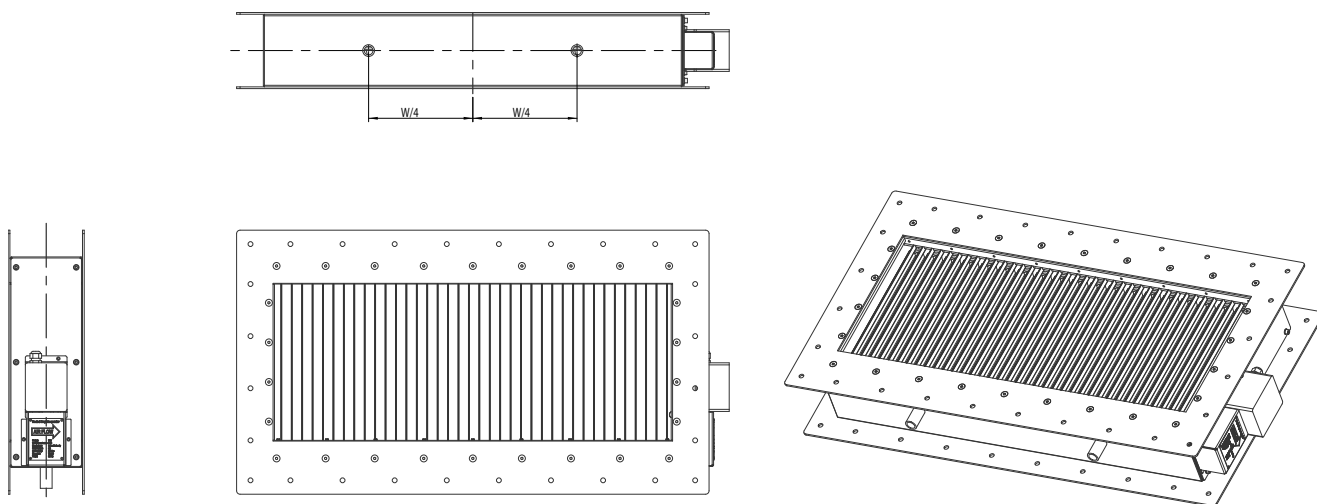

DRAIN PIPE SIZES

WELD-ON PIPE	Ø Inch	L mm	A mm	d1 mm	d2 mm
Aluminium EN AW 6060	1	50	25	25	35
Stainless steel EN 1.4404 (AISI316L)	1	40	20	27	34

Other drain types available on request.

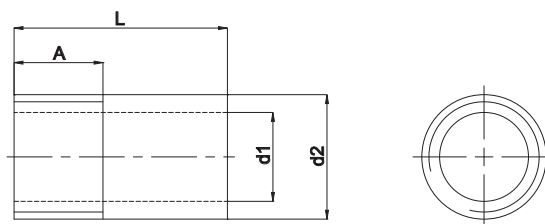

ELECTRICAL DATA AND CONTROL

- Power supply 230V, 1 Phase AC
- Electrical heating capacities vary between 2,5 kW/m² - 3,7 kW/m², depending on the ambient temperature
- For optimal performance and control, contact Halton

OPTIONAL FEATURES

THE EXTREME CONDITIONS SOLUTION (ECS)

When intake air is crucial during extreme icing conditions, the Halton Extreme Condition Solution (ECS) keeps the air intake open. The Halton ECS combines the DSA heated droplet separators with either shut-off or fire dampers with an additional option for filter units. The solution can allow one or more separators to remain open and ice-free while the other separator is in defrost mode during critical atmospheric conditions. This is achieved by shutting-off a section of the DSA to allow the ice build-up to melt.

There are a few control methods available to alternate the opening/closing sequence of the ECS to ensure a free flow of unrestricted air.



"GOOSENECK" - REDUCING THE WIND EFFECT

Strong wind can adversely affect the performance of the droplet separator. In environments where stormy weather is regular Halton recommends using a "gooseneck" air intake with droplet separators. A gooseneck can be installed directly to a duct installation type of droplet separator.

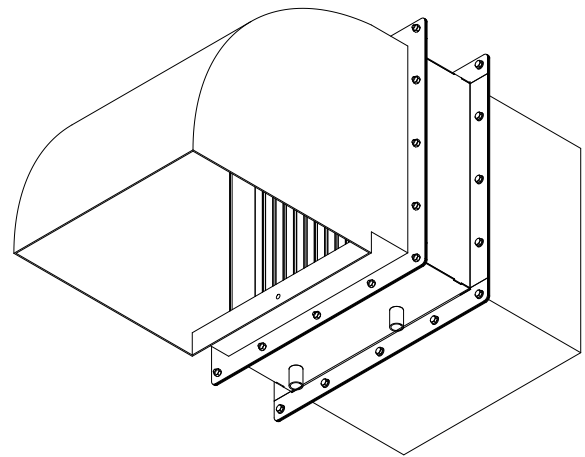
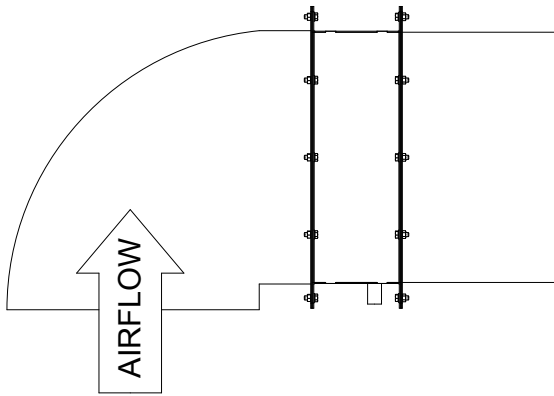

FILTERS

ISO COARSE 70% FILTER

Panel filters are manufactured of progressive thermally smoothed synthetic polyester having high dust holding capacity and constancy for humidity. The filters are used in the general ventilation system for air purification.

EPM10 70%, EPM2,5 65%, EPM1 50% BAG FILTERS

The materials of the synthetic fine filters are high-quality and durable, progressive mounted synthetic fibres. The filters can be used in example for air purification of the intake air.

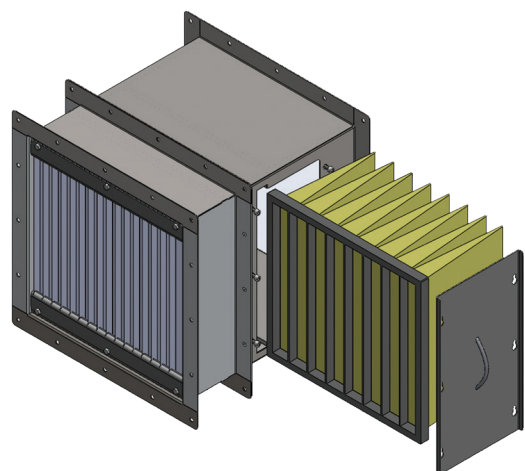

ATEX APPROVED FILTERS

Halton also offers ATEX approved filters for droplet separators.

M07Y2024/Halton reserves the right to alter products without notice.

INSTALLATION IN CONJUNCTION WITH A DAMPER

Halton droplet separator can be connected to a Halton damper with or without a connection piece. In both cases, the construction is modified to fit the damper. Connecting DSH with a fire damper must be mentioned when ordering products. Special flanges and drilling patterns are available for all models on request. The structural flexibility of dampers and high-quality combined with a wide range of accessories (ex-actuators) and special steels, enable Halton to offer tailored solutions for its customers. Combining Halton droplet separator to damper offers customers a compact solution for air intake that also saves space. The products are recommended to be connected at Halton factory.

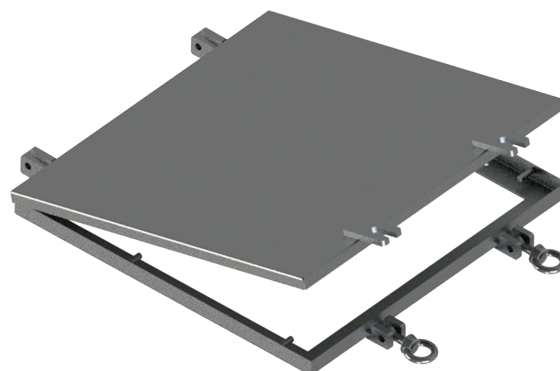

WEATHERTIGHT HATCH

Weather-tight hatch is used e.g. to shut down the intake close to the waterline in the event of rough seas. See a separate brochure on weather-tight hatch called Halton WTH.

PRESSURE DROP AND SOUND DATA LPA[DB] DSA EFFICIENCY RESULTS

DSA aluminium, pitch spacing 28 mm. Velocity based on the face area. Single-stage DSA, pitch spacing 28 mm

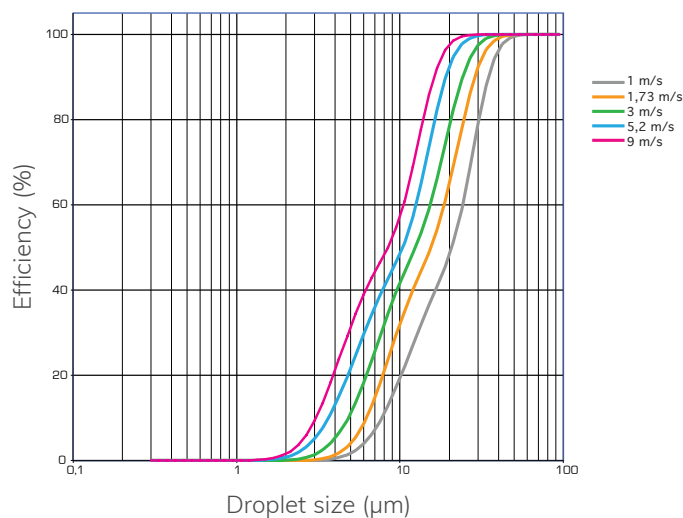
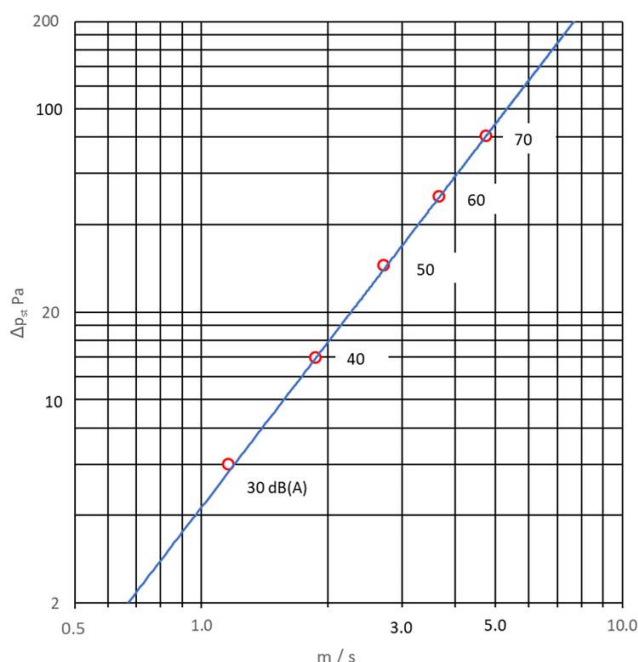

PERFORMANCE DATA

- Effectiveness for removal of simulated rain
- EN 13030:2001
- Rainfall rate: 75 (l/h)/m², (75 mm/h)
- Vertical installation

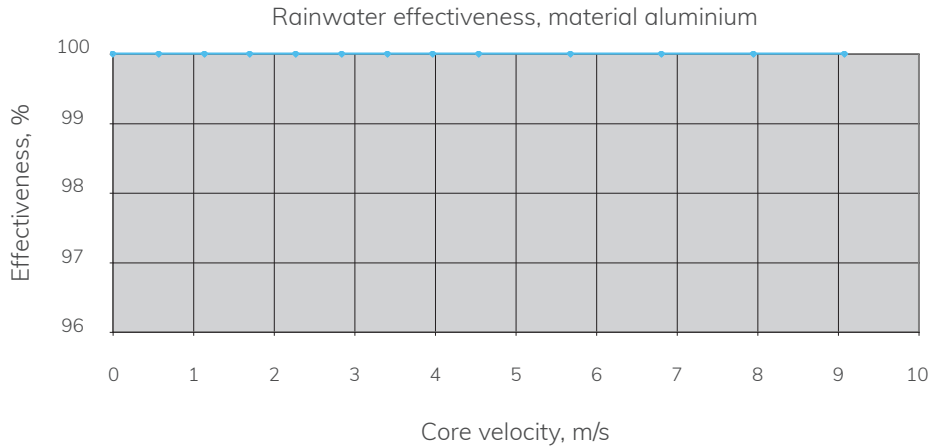

WEIGHTS

WEIGHTS OF DSA INCLUDING FRAME, 1 FLANGE, ALUMINIUM (KG), PITCH SPACING 28 MM

H/HEIGHT (mm)	B / WIDTH (mm)																								
	300	350	400	450	500	550	600	650	700	750	800	850	900	950	1000	1050	1100	1150	1200	1250	1300	1350	1400	1450	1500
300	10	12	13	14	16	17	18	20	21	22	23	24	26	27	28	31	33	34	35	37	38	39	41	42	43
350	12	13	14	16	17	19	20	22	23	24	26	27	29	30	31	35	36	37	39	41	42	44	45	46	48
400	13	14	16	17	19	20	22	24	25	27	28	30	31	33	34	38	40	41	43	45	46	48	49	51	52
450	14	16	17	19	21	22	24	26	27	29	31	32	34	36	37	41	43	45	46	48	50	52	54	55	57
500	15	17	18	20	23	24	26	28	29	32	34	35	37	39	40	44	47	48	50	52	54	56	58	59	62
550	16	18	20	22	24	26	28	30	32	34	36	38	40	42	44	48	50	52	54	56	58	60	62	64	66
600	17	20	21	24	26	27	30	32	34	36	39	40	43	45	47	51	53	55	58	60	62	64	67	68	71
650	18	21	22	25	28	29	32	34	36	39	41	43	45	48	50	54	57	59	61	64	66	68	71	73	75
700	19	22	24	27	29	31	34	37	38	41	44	45	48	51	53	58	60	62	65	68	70	72	75	77	80
750	21	23	25	28	31	33	36	39	40	43	46	48	51	54	56	61	64	66	69	72	73	76	79	81	84
800	22	25	27	30	33	35	38	41	43	46	49	51	54	57	59	64	67	69	72	75	77	81	84	86	89
850	23	26	28	31	34	36	40	43	45	48	51	53	57	60	62	67	71	73	76	79	81	85	88	90	93
900	24	27	29	33	36	38	42	45	47	51	54	56	59	63	65	71	74	76	80	83	85	89	92	94	98
950	25	29	31	34	38	40	44	47	49	53	56	59	62	66	68	74	78	80	83	87	89	93	96	99	102
1000	26	30	32	36	40	42	46	49	52	55	59	61	65	69	71	77	81	83	87	91	93	97	101	103	107
1050	29	33	35	39	43	46	50	54	56	60	64	66	70	74	76	80	84	87	91	95	97	101	105	107	111
1100	30	34	37	41	45	47	52	56	58	62	66	69	73	77	80	84	88	90	94	99	101	105	109	112	116
1150	31	36	38	42	47	49	54	58	60	65	69	72	76	80	83	87	91	94	98	102	105	109	114	116	120
1200	32	37	40	44	48	51	56	60	63	67	72	74	79	83	86	90	95	97	102	106	109	113	118	121	125

The weights on the table are indicative and do not include a filter and damper.

Consult Halton for weights for different types of configurations and weights for modular constructions. Minimum size for Halton DSA droplet separator is 300x300 mm (WxH). Maximum size for a single separator is 1500x1200 mm (WxH). Sizes with 50 mm divisions. Modular construction is available up to 3000x2400 mm (WxH).